

Python code for Artificial Intelligence Foundations of Computational Agents

David L. Poole and Alan K. Mackworth

Version 0.9.18 of March 10, 2026.

<https://aipython.org> <https://artint.info>

©David L Poole and Alan K Mackworth 2017-2025.

All code is licensed under a Creative Commons Attribution-NonCommercial-ShareAlike 4.0 International License. See: <https://creativecommons.org/licenses/by-nc-sa/4.0/deed.en>

This document and all the code can be downloaded from
<https://artint.info/AIPython/> or from <https://aipython.org>

The authors and publisher of this book have used their best efforts in preparing this book. These efforts include the development, research and testing of the programs to determine their effectiveness. The authors and publisher make no warranty of any kind, expressed or implied, with regard to these programs or the documentation contained in this book. The author and publisher shall not be liable in any event for incidental or consequential damages in connection with, or arising out of, the furnishing, performance, or use of these programs.

Contents

Contents	3
1 Python for Artificial Intelligence	9
1.1 Why Python?	9
1.2 Getting Python	10
1.3 Running Python	10
1.4 Pitfalls	11
1.5 Features of Python	11
1.5.1 f-strings	11
1.5.2 Lists, Tuples, Sets, Dictionaries and Comprehensions . .	12
1.5.3 Generators	13
1.5.4 Functions as first-class objects	14
1.6 Useful Libraries	16
1.6.1 Timing Code	16
1.6.2 Plotting: Matplotlib	16
1.7 Utilities	18
1.7.1 Display	18
1.7.2 Argmax	19
1.7.3 Probability	20
1.8 Testing Code	21
2 Agent Architectures and Hierarchical Control	25
2.1 Representing Agents and Environments	25
2.2 Paper buying agent and environment	27
2.2.1 The Environment	27
2.2.2 The Agent	28

2.2.3	Plotting	29
2.3	Hierarchical Controller	31
2.3.1	Body	31
2.3.2	Middle Layer	33
2.3.3	Top Layer	35
2.3.4	World	35
2.3.5	Plotting	36
3	Searching for Solutions	41
3.1	Representing Search Problems	41
3.1.1	Explicit Representation of Search Graph	43
3.1.2	Paths	45
3.1.3	Example Search Problems	47
3.2	Generic Searcher and Variants	54
3.2.1	Searcher	54
3.2.2	GUI for Tracing Search	55
3.2.3	Frontier as a Priority Queue	60
3.2.4	A^* Search	61
3.2.5	Multiple Path Pruning	63
3.3	Branch-and-bound Search	65
4	Reasoning with Constraints	69
4.1	Constraint Satisfaction Problems	69
4.1.1	Variables	69
4.1.2	Constraints	70
4.1.3	CSPs	71
4.1.4	Examples	74
4.2	A Simple Depth-first Solver	83
4.3	Converting CSPs to Search Problems	85
4.4	Consistency Algorithms	87
4.4.1	Direct Implementation of Domain Splitting	89
4.4.2	Consistency GUI	91
4.4.3	Domain Splitting as an interface to graph searching	94
4.5	Solving CSPs using Stochastic Local Search	96
4.5.1	Any-conflict	98
4.5.2	Two-Stage Choice	99
4.5.3	Updatable Priority Queues	101
4.5.4	Plotting Run-Time Distributions	103
4.5.5	Testing	104
4.6	Discrete Optimization	105
4.6.1	Branch-and-bound Search	107
5	Propositions and Inference	109
5.1	Representing Knowledge Bases	109
5.2	Bottom-up Proofs (with askables)	112

- 5.3 Top-down Proofs (with askables) 114
- 5.4 Debugging and Explanation 115
- 5.5 Assumables 119
- 5.6 Negation-as-failure 122

- 6 Deterministic Planning 125**
- 6.1 Representing Actions and Planning Problems 125
 - 6.1.1 Robot Delivery Domain 126
 - 6.1.2 Blocks World 128
- 6.2 Forward Planning 130
 - 6.2.1 Defining Heuristics for a Planner 133
- 6.3 Regression Planning 135
 - 6.3.1 Defining Heuristics for a Regression Planner 137
- 6.4 Planning as a CSP 138
- 6.5 Partial-Order Planning 142

- 7 Supervised Machine Learning 149**
- 7.1 Representations of Data and Predictions 150
 - 7.1.1 Creating Boolean Conditions from Features 153
 - 7.1.2 Evaluating Predictions 155
 - 7.1.3 Creating Test and Training Sets 157
 - 7.1.4 Importing Data From File 158
 - 7.1.5 Augmented Features 161
- 7.2 Generic Learner Interface 163
- 7.3 Learning With No Input Features 164
 - 7.3.1 Evaluation 167
- 7.4 Decision Tree Learning 168
- 7.5 k-fold Cross Validation and Parameter Tuning 173
- 7.6 Linear Regression and Classification 176
 - 7.6.1 Rating Data 183
- 7.7 Boosting 189
 - 7.7.1 Gradient Tree Boosting 192

- 8 Neural Networks and Deep Learning 195**
- 8.1 Layers 195
 - 8.1.1 Linear Layer 196
 - 8.1.2 ReLU Layer 198
 - 8.1.3 Sigmoid Layer 199
- 8.2 Feedforward Networks 199
- 8.3 Optimizers 201
 - 8.3.1 Stochastic Gradient Descent 201
 - 8.3.2 Momentum 202
 - 8.3.3 RMS-Prop 203
- 8.4 Dropout 204
- 8.5 Examples 204

8.6	Plotting Performance	206
8.7	Language Tokenizer	210
8.8	Bigram with Empirical Probabilities	217
8.9	N-Grams with token embeddings	218
9	Reasoning with Uncertainty	227
9.1	Representing Probabilistic Models	227
9.2	Representing Factors	227
9.3	Conditional Probability Distributions	229
9.3.1	Logistic Regression	230
9.3.2	Noisy-or	230
9.3.3	Tabular Factors and Prob	231
9.3.4	Decision Tree Representations of Factors	232
9.4	Graphical Models	234
9.4.1	Showing Belief Networks	236
9.4.2	Example Belief Networks	236
9.5	Inference Methods	242
9.5.1	Showing Posterior Distributions	243
9.6	Naive Search	245
9.7	Recursive Conditioning	246
9.8	Variable Elimination	250
9.9	Stochastic Simulation	254
9.9.1	Sampling from a discrete distribution	254
9.9.2	Sampling Methods for Belief Network Inference	256
9.9.3	Rejection Sampling	256
9.9.4	Likelihood Weighting	257
9.9.5	Particle Filtering	258
9.9.6	Examples	260
9.9.7	Gibbs Sampling	261
9.9.8	Plotting Behavior of Stochastic Simulators	263
9.10	Hidden Markov Models	265
9.10.1	Exact Filtering for HMMs	267
9.10.2	Localization	269
9.10.3	Particle Filtering for HMMs	272
9.10.4	Generating Examples	274
9.11	Dynamic Belief Networks	275
9.11.1	Representing Dynamic Belief Networks	275
9.11.2	Unrolling DBNs	279
9.11.3	DBN Filtering	281
10	Learning with Uncertainty	283
10.1	Bayesian Learning	283
10.2	K-means	287
10.3	EM	292

11 Causality	299
11.1 Do Questions	299
11.2 Counterfactual Reasoning	302
11.2.1 Choosing Deterministic System	302
11.2.2 Firing Squad Example	306
12 Planning with Uncertainty	309
12.1 Decision Networks	309
12.1.1 Example Decision Networks	311
12.1.2 Decision Functions	317
12.1.3 Recursive Conditioning for Decision Networks	318
12.1.4 Variable elimination for decision networks	321
12.2 Markov Decision Processes	324
12.2.1 Problem Domains	325
12.2.2 Value Iteration	334
12.2.3 Value Iteration GUI for Grid Domains	335
12.2.4 Asynchronous Value Iteration	339
13 Reinforcement Learning	343
13.1 Representing Agents and Environments	343
13.1.1 Environments	343
13.1.2 Agents	344
13.1.3 Simulating an Environment-Agent Interaction	345
13.1.4 Party Environment	347
13.1.5 Environment from a Problem Domain	348
13.1.6 Monster Game Environment	349
13.2 Q Learning	352
13.2.1 Exploration Strategies	355
13.2.2 Testing Q-learning	355
13.3 Q-learning with Experience Replay	357
13.4 Stochastic Policy Learning Agent	360
13.5 Model-based Reinforcement Learner	362
13.6 Reinforcement Learning with Features	365
13.6.1 Representing Features	365
13.6.2 Feature-based RL learner	368
13.7 GUI for RL	371
14 Multiagent Systems	379
14.1 Minimax	379
14.1.1 Creating a two-player game	380
14.1.2 Minimax and α - β Pruning	383
14.2 Multiagent Learning	385
14.2.1 Simulating Multiagent Interaction with an Environment	385
14.2.2 Example Games	388
14.2.3 Testing Games and Environments	390

15	Individuals and Relations	393
15.1	Representing Datalog and Logic Programs	393
15.2	Unification	395
15.3	Knowledge Bases	396
15.4	Top-down Proof Procedure	398
15.5	Logic Program Example	400
16	Knowledge Graphs and Ontologies	403
16.1	Triple Store	403
16.2	Integrating Datalog and Triple Store	406
17	Relational Learning	409
17.1	Collaborative Filtering	409
17.1.1	Plotting	413
17.1.2	Loading Rating Sets from Files and Websites	416
17.1.3	Ratings of top items and users	417
17.2	Relational Probabilistic Models	419
18	Version History	425
	Bibliography	427
	Index	429

Python for Artificial Intelligence

AIPython contains runnable code for the book *Artificial Intelligence, foundations of computational agents, 3rd Edition* [Poole and Mackworth, 2023]. It has the following design goals:

- Readability is more important than efficiency, although the asymptotic complexity is not compromised. AIPython is not a replacement for well-designed libraries, or optimized tools. Think of it like a model of an engine made of glass, so you can see the inner workings; don't expect it to power a big truck, but it lets you see how an engine works to power a truck.
- It uses as few libraries as possible. A reader only needs to understand Python. Libraries hide details that we make explicit. The only library used is matplotlib for plotting and drawing.

1.1 Why Python?

We use Python because Python programs can be close to pseudo-code. It is designed for humans to read.

Python is reasonably efficient. Efficiency is usually not a problem for small examples. If your Python code is not efficient enough, a general procedure to improve it is to find out what is taking most of the time, and implement just that part more efficiently in some lower-level language. Many lower-level languages interoperate with Python nicely. This will result in much less programming and more efficient code (because you will have more time to optimize) than writing everything in a lower-level language. Much of the code here is more efficiently implemented in libraries that are more difficult to understand.

1.2 Getting Python

You need Python 3.9 or later (<https://python.org/>) and a compatible version of matplotlib (<https://matplotlib.org/>). This code is *not* compatible with Python 2 (e.g., with Python 2.7).

Download and install the latest Python 3 release from <https://python.org/> or <https://www.anaconda.com/download> (free download includes many libraries). This should also install pip. You can install matplotlib using

```
pip install matplotlib
```

in a terminal shell (not in Python). That should “just work”. If not, try using pip3 instead of pip.

The command python or python3 should then start the interactive Python shell. You can quit Python with a control-D or with quit().

To upgrade matplotlib to the latest version (which you should do if you install a new version of Python) do:

```
pip install --upgrade matplotlib
```

We recommend using the enhanced interactive python **ipython** (<https://ipython.org/>) [Pérez and Granger, 2007]. To install ipython after you have installed python do:

```
pip install ipython
```

1.3 Running Python

We assume that everything is done with an interactive Python shell. You can either do this with an IDE, such as IDLE that comes with standard Python distributions, or just running ipython or python (or perhaps ipython3 or python3) from a shell.

Here we describe the most simple version that uses no IDE. If you download the zip file, and cd to the “aipython” folder where the .py files are, you should be able to do the following, with user input in bold. The first python command is in the operating system shell; the -i is important to enter interactive mode.

```
python -i searchGeneric.py
```

```
Testing problem 1:
```

```
7 paths have been expanded and 4 paths remain in the frontier
```

```
Path found: A --> C --> B --> D --> G
```

```
Passed unit test
```

```
>>> searcher2 = AStarSearcher(searchProblem.acyclic_delivery_problem) #A*
```

```
>>> searcher2.search() # find first path
```

```
16 paths have been expanded and 5 paths remain in the frontier
```

```
o103 --> o109 --> o119 --> o123 --> r123
```

```
>>> searcher2.search() # find next path
```

```

21 paths have been expanded and 6 paths remain in the frontier
o103 --> b3 --> b4 --> o109 --> o119 --> o123 --> r123
>>> searcher2.search() # find next path
28 paths have been expanded and 5 paths remain in the frontier
o103 --> b3 --> b1 --> b2 --> b4 --> o109 --> o119 --> o123 --> r123
>>> searcher2.search() # find next path
No (more) solutions. Total of 33 paths expanded.
>>>

```

You can then interact at the last prompt.

There are many textbooks for Python. The best source of information about python is <https://www.python.org/>. The documentation is at <https://docs.python.org/3/>.

The rest of this chapter is about what is special about the code for AI tools. We only use the standard Python library and matplotlib. All of the exercises can be done (and should be done) without using other libraries; the aim is for you to spend your time thinking about how to solve the problem rather than searching for pre-existing solutions.

1.4 Pitfalls

It is important to know when side effects occur. Often AI programs consider what would/might happen given certain conditions. In many such cases, we don't want side effects. When an agent acts in the world, side effects are appropriate.

In Python, you need to be careful to understand side effects. For example, the inexpensive function to add an element to a list, namely `append`, changes the list. In a functional language like Haskell or Lisp, adding a new element to a list, without changing the original list, is a cheap operation. For example if x is a list containing n elements, adding an extra element to the list in Python (using `append`) is fast, but it has the side effect of changing the list x . To construct a new list that contains the elements of x plus a new element, without changing the value of x , entails copying the list, or using a different representation for lists. In the searching code, we will use a different representation for lists for this reason.

1.5 Features of Python

1.5.1 f-strings

Python can use matching `'`, `"`, `'''` or `"""`, the latter two respecting line breaks in the string. We use the convention that when the string denotes a unique symbol, we use single quotes, and when it is designed to be for printing, we use double quotes.

We make extensive use of f-strings <https://docs.python.org/3/tutorial/inputoutput.html>. In its simplest form

```
f"str1{e1}str2{e2}str3"
```

where `e1` and `e2` are expressions, is an abbreviation for

```
"str1"+str(e1)+"str2"+str(e2)+"str3"
```

where `+` is string concatenation, and `str` is a function that returns a string representation of its argument.

1.5.2 Lists, Tuples, Sets, Dictionaries and Comprehensions

We make extensive uses of lists, tuples, sets and dictionaries (dicts). See <https://docs.python.org/3/library/stdtypes.html>. Lists use “[...]”, dictionaries use “{key : value,...}”, sets use “{...}” (without the :), tuples use “(...)”.

One of the nice features of Python is the use of **comprehensions**: list, tuple, set and dictionary comprehensions.

A list comprehension is of the form

```
[fe for e in iter if cond]
```

is the list values `fe` for each `e` in `iter` for which `cond` is true. The “if `cond`” part is optional, but the “for” and “in” are not optional. Here `e` is a variable (or a pattern that can be on the left side of =), `iter` is an iterator, which can generate a stream of data, such as a list, a set, a range object (to enumerate integers between ranges) or a file. `cond` is an expression that evaluates to either True or False for each `e`, and `fe` is an expression that will be evaluated for each value of `e` for which `cond` returns True. For example:

```
>>> [e*e for e in range(20) if e%2==0]
[0, 4, 16, 36, 64, 100, 144, 196, 256, 324]
```

Comprehensions can also be used for sets and dictionaries. For example, the following creates an index for list `a`:

```
>>> a = ["a", "f", "bar", "b", "a", "aaaaa"]
>>> ind = {a[i]:i for i in range(len(a))}
>>> ind
{'a': 4, 'f': 1, 'bar': 2, 'b': 3, 'aaaaa': 5}
>>> ind['b']
3
```

which means that 'b' is the element with index 3 in the list.

The assignment of `ind` could have also be written as:

```
>>> ind = {val:i for (i,val) in enumerate(a)}
```

where `enumerate` is a built-in function that, given a dictionary, returns an generator of (`index, value`) pairs.

1.5.3 Generators

Python has generators which can be used for a form of lazy evaluation – only computing values when needed.

A comprehension in round parentheses gives a generator that can generate the elements as needed. The result can go in a list or used in another comprehension, or can be called directly using `next`. The procedure `next` takes an iterator and returns the next element (advancing the iterator); it raises a `StopIteration` exception if there is no next element. The following shows a simple example, where user input is prepended with `>>>`

```
>>> a = (e*e for e in range(20) if e%2==0)
>>> next(a)
0
>>> next(a)
4
>>> next(a)
16
>>> list(a)
[36, 64, 100, 144, 196, 256, 324]
>>> next(a)
Traceback (most recent call last):
  File "<stdin>", line 1, in <module>
StopIteration
```

Notice how `list(a)` continued on the enumeration, and got to the end of it.

To make a procedure into a generator, the `yield` command returns a value that is obtained with `next`. It is typically used to enumerate the values for a for loop or in generators. (The `yield` command can also be used for coroutines, but AIPython only uses it for generators.)

A version of the built-in `range`, with 2 or 3 arguments (and positive steps) can be implemented as:¹

```
pythonDemo.py — Some tricky examples
11 def myrange(start, stop, step=1):
12     """enumerates the values from start in steps of size step that are
13     less than stop.
14     """
15     assert step>0, f"only positive steps implemented in myrange: {step}"
16     i = start
17     while i<stop:
18         yield i
19         i += step
20
21 print("list(myrange(2,30,3)):", list(myrange(2,30,3)))
```

¹Numbered lines are Python code available in the code-directory, `aipython`. The name of the file is given in the gray text above the listing. The numbers correspond to the line numbers in that file.

The built-in `range` is unconventional in how it handles a single argument, as the single argument acts as the second argument of the function. The built-in `range` also allows for indexing (e.g., `range(2, 30, 3)[2]` returns 8), but the above implementation does not. However `myrange` also works for floats, whereas the built-in `range` does not.

Exercise 1.1 Implement a version of `myrange` that acts like the built-in version when there is a single argument. (Hint: make the second argument have a default value that can be recognized in the function.) There is no need to make it work with indexing.

`Yield` can be used to generate the same sequence of values as in the example above.

```
pythonDemo.py — (continued)
23 def ga(n):
24     """generates square of even nonnegative integers less than n"""
25     for e in range(n):
26         if e%2==0:
27             yield e*e
28 a = ga(20)
```

The sequence of `next(a)`, and `list(a)` gives exactly the same results as the comprehension at the start of this section.

It is straightforward to write a version of the built-in `enumerate` called `myenumerate`:

```
pythonDemo.py — (continued)
30 def myenumerate(iter, start=0):
31     i = start
32     for e in iter:
33         yield i,e
34         i += 1
```

1.5.4 Functions as first-class objects

Python can create lists and other data structures that contain functions. There is an issue that tricks many newcomers to Python. For a local variable in a function, the function uses the last value of the variable when the function is *called*, not the value of the variable when the function was defined (this is called “late binding”). This means if you want to use the value a variable has when the function is created, you need to save the current value of that variable. Whereas Python uses “late binding” by default, the alternative that newcomers often expect is “early binding”, where a function uses the value a variable had when the function was defined. The following examples show how early binding can be implemented.

Consider the following programs designed to create a list of 5 functions, where the *i*th function in the list is meant to add *i* to its argument:

```

pythonDemo.py — (continued)
36 fun_list1 = []
37 for i in range(5):
38     def fun1(e):
39         return e+i
40     fun_list1.append(fun1)
41
42 fun_list2 = []
43 for i in range(5):
44     def fun2(e,iv=i):
45         return e+iv
46     fun_list2.append(fun2)
47
48 fun_list3 = [lambda e: e+i for i in range(5)]
49
50 fun_list4 = [lambda e,iv=i: e+iv for i in range(5)]
51
52 i=56

```

Try to predict, and then test to see the output, of the output of the following calls, remembering that the function uses the latest value of any variable that is not bound in the function call:

```

pythonDemo.py — (continued)
54 # in Shell do
55 ## ipython -i pythonDemo.py
56 # Try these (copy text after the comment symbol and paste in the Python
    prompt):
57 # print([f(10) for f in fun_list1])
58 # print([f(10) for f in fun_list2])
59 # print([f(10) for f in fun_list3])
60 # print([f(10) for f in fun_list4])

```

In the first for-loop, the function `fun1` uses `i`, whose value is the last value it was assigned. In the second loop, the function `fun2` uses `iv`. There is a separate `iv` variable for each function, and its value is the value of `i` when the function was defined. Thus `fun1` uses late binding, and `fun2` uses early binding. `fun_list3` and `fun_list4` are equivalent to the first two (except `fun_list4` uses a different `i` variable).

One of the advantages of using the embedded definitions (as in `fun1` and `fun2` above) over the lambda is that it is possible to add a `__doc__` string, which is the standard for documenting functions in Python, to the embedded definitions.

1.6 Useful Libraries

1.6.1 Timing Code

In order to compare algorithms, you may want to compute how long a program takes to run; this is called the **run time** of the program. The most straightforward way to compute the run time of `foo.bar(aaa)` is to use `time.perf_counter()`, as in:

```
import time
start_time = time.perf_counter()
foo.bar(aaa)
end_time = time.perf_counter()
print("Time:", end_time - start_time, "seconds")
```

Note that `time.perf_counter()` measures clock time; so this should be done without user interaction between the calls. On the interactive python shell, you should do:

```
start_time = time.perf_counter(); foo.bar(aaa); end_time = time.perf_counter()
```

If this time is very small (say less than 0.2 second), it is probably very inaccurate; run your code multiple times to get a more accurate count. For this you can use `timeit` (<https://docs.python.org/3/library/timeit.html>). To use `timeit` to time the call to `foo.bar(aaa)` use:

```
import timeit
time = timeit.timeit("foo.bar(aaa)",
                    setup="from __main__ import foo,aaa", number=100)
```

The setup is needed so that Python can find the meaning of the names in the string that is called. This returns the number of seconds to execute `foo.bar(aaa)` 100 times. The number should be set so that the run time is at least 0.2 seconds.

You should not trust a single measurement as that can be confounded by interference from other processes. `timeit.repeat` can be used for running `timeit` a few (say 3) times. When reporting the time of any computation, you should be explicit and explain what you are reporting. Usually the minimum time is the one to report (as it is the run with less interference).

1.6.2 Plotting: Matplotlib

The standard plotting for Python is `matplotlib` (<https://matplotlib.org/>). We will use the most basic plotting using the `pyplot` interface.

Here is a simple example that uses most of AIPython uses. The output is shown in Figure 1.1.

```
pythonDemo.py — (continued)
62 | import matplotlib.pyplot as plt
63 |
```

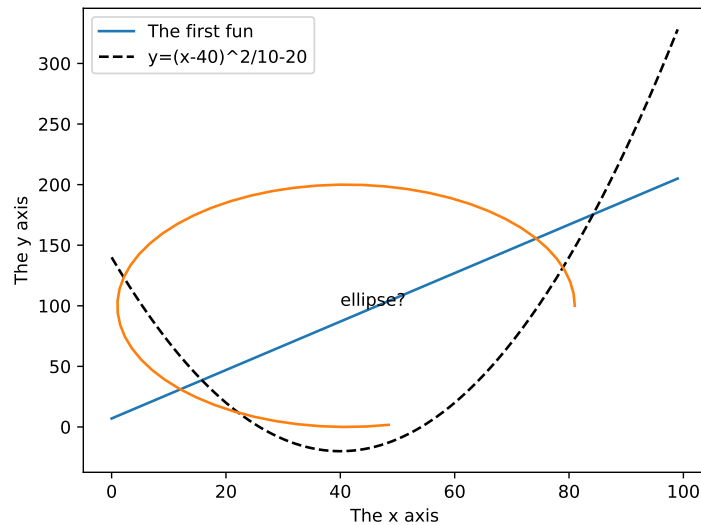

Figure 1.1: Result of pythonDemo code

```

64 def myplot(minv,maxv,step,fun1,fun2):
65     global fig, ax # allow them to be used outside myplot()
66     plt.ion() # make it interactive
67     fig, ax = plt.subplots()
68     ax.set_xlabel("The x axis")
69     ax.set_ylabel("The y axis")
70     ax.set_xscale('linear') # Makes a 'log' or 'linear' scale
71     xvalues = range(minv,maxv,step)
72     ax.plot(xvalues,[fun1(x) for x in xvalues],
73            label="The first fun")
74     ax.plot(xvalues,[fun2(x) for x in xvalues], linestyle='--',color='k',
75            label=fun2.__doc__) # use the doc string of the function
76     ax.legend(loc="upper right") # display the legend
77
78 def slin(x):
79     """y=2x+7"""
80     return 2*x+7
81 def sqfun(x):
82     """y=(x-40)^2/10-20"""
83     return (x-40)**2/10-20
84
85 # Try the following from shell:
86 # python -i pythonDemo.py
87 # myplot(0,100,1,slin,sqfun)
88 # ax.legend(loc="best")
89 # import math
90 # ax.plot([41+40*math.cos(th/10) for th in range(50)],

```

```

91 | #         [100+100*math.sin(th/10) for th in range(50)])
92 | # ax.text(40,100,"ellipse?")
93 | # ax.set_xscale('log')

```

At the end of the code are some commented-out commands you should try in interactive mode. Cut from the file and paste into Python (and remember to remove the comments symbol and leading space).

1.7 Utilities

1.7.1 Display

To keep things simple, using only standard Python, AIPython code is written using a text-oriented tracing.

The method `self.display` is used to trace the program. Any call

```
self.display(level, to_print ...)
```

where the *level* is less than or equal to the value for `max_display_level` will be printed. The *to_print* ... can be anything that is accepted by the built-in `print` (including any keyword arguments).

The definition of `display` is:

```

_____display.py — A simple way to trace the intermediate steps of algorithms. _____
11 | class Displayable(object):
12 |     """Class that uses 'display'.
13 |     The amount of detail is controlled by max_display_level
14 |     """
15 |     max_display_level = 1 # can be overridden in subclasses or instances
16 |
17 |     def display(self, level, *args, **nargs):
18 |         """print the arguments if level is less than or equal to the
19 |         current max_display_level.
20 |         level is an integer.
21 |         the other arguments are whatever arguments print can take.
22 |         """
23 |         if level <= self.max_display_level:
24 |             print(*args, **nargs) ##if error you are using Python2 not
                Python3

```

In this code, `args` gets a tuple of the positional arguments, and `nargs` gets a dictionary of the keyword arguments. This will not work in Python 2, and will give an error.

Any class that wants to use `display` can be made a subclass of `Displayable`.

To change the maximum display level to 3 for a class do:

```
Classname.max_display_level = 3
```

which will make calls to `display` in that class print when the value of `level` is less-than-or-equal to 3. The default display level is 1. It can also be changed for individual objects (the object value overrides the class value).

The value of `max_display_level` by convention is:

0 display nothing

1 display solutions (nothing that happens repeatedly)

2 also display the values as they change (little detail through a loop)

3 also display more details

4 and above even more detail

To implement a graphical user interface (GUI), the definition of `display` can be overridden. See, for example, `SearcherGUI` in Section 3.2.2 and `ConsistencyGUI` in Section 4.4.2. These GUIs use the AIPython code unchanged.

1.7.2 Argmax

Python has a built-in `max` function that takes a generator (or a list or set) and returns the maximum value. The `argmaxall` method takes a generator of $(element, value)$ pairs, as for example is generated by the built-in `enumerate(list)` for lists or `dict.items()` for dictionaries. It returns a list of all elements with maximum value; `argmaxe` returns one of these values at random. The `argmax` method takes a list and returns the index of a random element that has the maximum value. `argmaxd` takes a dictionary and returns a key with maximum value.

```

_____utilities.py — AIPython useful utilities_____
11 import random
12 import math
13
14 def argmaxall(gen):
15     """gen is a generator of (element,value) pairs, where value is a real.
16     argmaxall returns a list of all of the elements with maximal value.
17     """
18     maxv = -math.inf    # negative infinity
19     maxvals = []      # list of maximal elements
20     for (e,v) in gen:
21         if v > maxv:
22             maxvals, maxv = [e], v
23         elif v == maxv:
24             maxvals.append(e)
25     return maxvals
26
27 def argmaxe(gen):
28     """gen is a generator of (element,value) pairs, where value is a real.
29     argmaxe returns an element with maximal value.

```

```

30     If there are multiple elements with the max value, one is returned at
        random.
31     """
32     return random.choice(argmaxall(gen))
33
34 def argmax(lst):
35     """returns maximum index in a list"""
36     return argmaxe(enumerate(lst))
37 # Try:
38 # argmax([1,6,3,77,3,55,23])
39
40 def argmaxd(dct):
41     """returns the arg max of a dictionary dct"""
42     return argmaxe(dct.items())
43 # Try:
44 # arxmaxd({2:5,5:9,7:7})

```

Exercise 1.2 Change `argmaxe` to have an optional argument that specifies whether you want the “first”, “last” or a “random” index of the maximum value returned. If you want the first or the last, you don’t need to keep a list of the maximum elements. Enable the other methods to have this optional argument, if appropriate.

1.7.3 Probability

For many of the simulations, we want to make a variable True with some probability. `flip(p)` returns True with probability p , and otherwise returns False.

```

_____ utilities.py — (continued) _____
45 def flip(prob):
46     """return true with probability prob"""
47     return random.random() < prob

```

The `select_from_dist` method takes in a *item : probability* dictionary, and returns one of the items in proportion to its probability. The probabilities should sum to 1 or more. If they sum to more than one, the excess is ignored.

```

_____ utilities.py — (continued) _____
49 def select_from_dist(item_prob_dist):
50     """ returns a value from a distribution.
51     item_prob_dist is an item:probability dictionary, where the
52     probabilities sum to 1.
53     returns an item chosen in proportion to its probability
54     """
55     ranreal = random.random()
56     for (it,prob) in item_prob_dist.items():
57         if ranreal < prob:
58             return it
59         else:
60             ranreal -= prob
61     raise RuntimeError(f"{item_prob_dist} is not a probability
        distribution")

```

1.8 Testing Code

It is important to test code early and test it often. We include a simple form of **unit test**. In your code, you should do more substantial testing than done here. Make sure you should also test boundary cases.

The following code tests `argmax`, but only if `utilities` is loaded in the top-level. If it is loaded in a module the test code is not run. The value of the current module is in `__name__` and if the module is run at the top-level, its value is `"__main__"`. See https://docs.python.org/3/library/__main__.html.

```

_____utilities.py — (continued)_____
63 def test():
64     """Test part of utilities"""
65     assert argmax([1,6,55,3,55,23]) in [2,4]
66     print("Passed unit test in utilities")
67     print("run test_aipython() to test (almost) everything")
68
69 if __name__ == "__main__":
70     test()

```

The following imports all of the python code and does a simple check of all of AIPython that has automatic checks. If you develop new algorithms or tests, add them here!

```

_____utilities.py — (continued)_____
72 def test_aipython():
73     import pythonDemo, display
74     # Agents: currently no tests
75     import agents, agentBuying, agentEnv, agentMiddle, agentTop,
        agentFollowTarget
76     # Search:
77     print("***** testing Search *****")
78     import searchGeneric, searchBranchAndBound, searchExample, searchTest
79     searchGeneric.test(searchGeneric.AStarSearcher)
80     searchBranchAndBound.test(searchBranchAndBound.DF_branch_and_bound)
81     searchTest.run(searchExample.problem1, "Problem 1")
82     import searchGUI, searchMPP, searchGrid
83     # CSP
84     print("\n***** testing CSP *****")
85     import cspExamples, cspDFS, cspSearch, cspConsistency, cspSLS
86     cspExamples.test_csp(cspDFS.dfs_solve1)
87     cspExamples.test_csp(cspSearch.solver_from_searcher)
88     cspExamples.test_csp(cspConsistency.ac_solver)
89     cspExamples.test_csp(cspConsistency.ac_search_solver)
90     cspExamples.test_csp(cspSLS.sls_solver)
91     cspExamples.test_csp(cspSLS.any_conflict_solver)
92     import cspConsistencyGUI, cspSoft
93     # Propositions
94     print("\n***** testing Propositional Logic *****")

```

```

95     import logicBottomUp, logicTopDown, logicExplain, logicAssumables,
        logicNegation
96     logicBottomUp.test()
97     logicTopDown.test()
98     logicExplain.test()
99     logicNegation.test()
100    # Planning
101    print("\n***** testing Planning *****")
102    import stripsHeuristic
103    stripsHeuristic.test_forward_heuristic()
104    stripsHeuristic.test_regression_heuristic()
105    import stripsCSPPanner, stripsPOP
106    # Learning
107    print("\n***** Learning with no inputs *****")
108    import learnProblem, learnNoInputs, learnDT, learnLinear
109    learnNoInputs.test_no_inputs(training_sizes=[4])
110    data = learnProblem.Data_from_file('data/carbool.csv', one_hot=True,
        target_index=-1, seed=123)
111    print("\n***** Decision Trees *****")
112    dtl=learnDT.DT_learner(data)
113    dtl.learn()
114    dtl.evaluate()
115    print("\n***** Linear Learning *****")
116    ll=learnLinear.Linear_learner(data)
117    ll.learn()
118    ll.evaluate()
119    import learnCrossValidation, learnBoosting
120    # Deep Learning
121    import learnNN
122    print("\n***** testing Neural Network Learning *****")
123    nn= learnNN.NN_from_arch(data, arch=[3])
124    nn.learn()
125    nn.evaluate()
126    # Uncertainty
127    print("\n***** testing Uncertainty *****")
128    import probGraphicalModels, probRC, probVE, probStochSim
129    probGraphicalModels.InferenceMethod.testIM(probRC.ProbSearch)
130    probGraphicalModels.InferenceMethod.testIM(probRC.ProbRC)
131    probGraphicalModels.InferenceMethod.testIM(probVE.VE)
132    probGraphicalModels.InferenceMethod.testIM(probStochSim.RejectionSampling,
        threshold=0.1)
133    probGraphicalModels.InferenceMethod.testIM(probStochSim.LikelihoodWeighting,
        threshold=0.1)
134    probGraphicalModels.InferenceMethod.testIM(probStochSim.ParticleFiltering,
        threshold=0.1)
135    probGraphicalModels.InferenceMethod.testIM(probStochSim.GibbsSampling,
        threshold=0.1)
136    import probHMM, probLocalization, probDBN
137    # Learning under uncertainty
138    print("\n***** Learning under Uncertainty *****")

```

```

139 import learnBayesian, learnKMeans, learnEM
140 learnKMeans.testKM()
141 learnEM.testEM()
142 # Causality: currently no tests
143 import probDo, probCounterfactual
144 # Planning under uncertainty
145 print("\\n***** Planning under Uncertainty *****")
146 import decnNetworks
147 decnNetworks.test(decnNetworks.fire_dn)
148 import mdpExamples
149 mdpExamples.test_MDP(mdpExamples.partyMDP)
150 import mdpGUI
151 # Reinforcement Learning:
152 print("\\n***** testing Reinforcement Learning *****")
153 import rlQLearner
154 rlQLearner.test_RL(rlQLearner.Q_learner, alpha_fun=lambda k:10/(9+k))
155 import rlQExperienceReplay
156 rlQLearner.test_RL(rlQExperienceReplay.Q_ER_learner, alpha_fun=lambda
    k:10/(9+k))
157 import rlStochasticPolicy
158 rlQLearner.test_RL(rlStochasticPolicy.StochasticPIAgent,
    alpha_fun=lambda k:10/(9+k))
159 import rlModelLearner
160 rlQLearner.test_RL(rlModelLearner.Model_based_reinforcement_learner)
161 import rlFeatures
162 rlQLearner.test_RL(rlFeatures.SARSA_LFA_learner,
    es_kwargs={'epsilon':1}, eps=4)
163 import rlQExperienceReplay, rlModelLearner, rlFeatures, rlGUI
164 # Multiagent systems: currently no tests
165 import rlStochasticPolicy, rlGameFeature
166 # Individuals and Relations
167 print("\\n***** testing Datalog and Logic Programming *****")
168 import relnExamples
169 relnExamples.test_ask_all()
170 # Knowledge Graphs and Ontologies
171 print("\\n***** testing Knowledge Graphs and Ontologies *****")
172 import knowledgeGraph, knowledgeReasoning
173 knowledgeGraph.test_kg()
174 # Relational Learning: currently no tests
175 import relnCollFilt, relnProbModels
176 print("\\n***** End of Testing*****")

```

Agent Architectures and Hierarchical Control

This implements the controllers described in Chapter 2 of Poole and Mackworth [2023]. It defines an architecture that is also used by reinforcement learning (Chapter 13) and multiagent learning (Section 14.2).

AIPython only provides sequential implementations of the control. More sophisticated version may have them run concurrently. Higher-levels call lower-levels. The higher-levels calling the lower-level works in simulated environments where the lower-level are written to make sure they return (and don't go on forever), and the higher level doesn't take too long (as the lower-levels will wait until called again). More realistic architecture have the layers running concurrently so the lower layer can keep reacting while the higher layers are carrying out more complex computation.

2.1 Representing Agents and Environments

Both agents and the environment are treated as objects in the sense of object-oriented programming, with an internal state they maintain, and can evaluate methods. In this chapter, only a single agent is allowed; Section 14.2 allows for multiple agents.

An **environment** takes in actions of the agents, updates its internal state and returns the next percept, using the method `do`.

An **agent** implements the method `select_action` that takes a percept and returns the next action, updating its internal state as appropriate.

The methods `do` and `select_action` are chained together to build a simulator. Initially the simulator needs either an action or a percept. There are two variants used:

- An agent implements the `initial_action(percept)` method which is used initially. This is the method used in the reinforcement learning chapter (page 343).
- The environment implements the `initial_percept()` method which gives the initial percept for the agent. This is the method is used in this chapter.

The state of the agent and the state of the environment are represented using standard Python variables, which are updated as the state changes. The percept and the actions are represented as variable-value dictionaries.

Agent and Environment are subclasses of `Displayable` so that they can use the display method described in Section 1.7.1. `raise NotImplementedError()` is a way to specify an abstract method that needs to be overridden in any implemented agent or environment.

```

agents.py — Agent and Controllers
11 from display import Displayable
12
13 class Agent(Displayable):
14
15     def initial_action(self, percept):
16         """return the initial action."""
17         return self.select_action(percept) # same as select_action
18
19     def select_action(self, percept):
20         """return the next action (and update internal state) given percept
21         percept is variable:value dictionary
22         """
23         raise NotImplementedError("go") # abstract method

```

The environment implements a `do(action)` method where `action` is a variable-value dictionary. This returns a percept, which is also a variable-value dictionary. The use of dictionaries allows for structured actions and percepts.

Note that

```

agents.py — (continued)
25 class Environment(Displayable):
26     def initial_percept(self):
27         """returns the initial percept for the agent"""
28         raise NotImplementedError("initial_percept") # abstract method
29
30     def do(self, action):
31         """does the action in the environment
32         returns the next percept """
33         raise NotImplementedError("Environment.do") # abstract method

```

The simulator is initialized with `initial_percept` and then the agent and the environment take turns in updating their states and returning the action and the percept. This simulator runs for n steps. A slightly more sophisticated simulator could run until some stopping condition.

```

agents.py — (continued)
35 class Simulate(Displayable):
36     """simulate the interaction between the agent and the environment
37     for n time steps.
38     """
39     def __init__(self, agent, environment):
40         self.agent = agent
41         self.env = environment
42         self.percept = self.env.initial_percept()
43         self.percept_history = [self.percept]
44         self.action_history = []
45
46     def go(self, n):
47         for i in range(n):
48             action = self.agent.select_action(self.percept)
49             self.display(2, f"i={i} action={action}")
50             self.percept = self.env.do(action)
51             self.display(2, f"    percept={self.percept}")

```

2.2 Paper buying agent and environment

To run the demo, in folder "aipython", load "agents.py", using e.g.,
`ipython -i agentBuying.py`, and copy and paste the commented-out
 commands at the bottom of that file.

This is an implementation of Example 2.1 of Poole and Mackworth [2023]. You might get different plots to Figures 2.2 and 2.3 as there is randomness in the environment.

2.2.1 The Environment

The environment state is given in terms of the time and the amount of paper in stock. It also remembers the in-stock history and the price history. The percept consists of the price and the amount of paper in stock. The action of the agent is the number to buy.

Here we assume that the price changes are obtained from the `price_delta` list which gives the change in price for each time. When the time is longer than the list, it repeats the list. Note that the sum of the changes is greater than zero, so that prices tend to increase. There is also randomness (noise) added to the prices. The agent cannot access the price model; it just observes the prices and the amount in stock.

```

agentBuying.py — Paper-buying agent
11 import random
12 from agents import Agent, Environment, Simulate
13 from utilities import select_from_dist

```

```

14
15 class TP_env(Environment):
16     price_delta = [0, 0, 0, 21, 0, 20, 0, -64, 0, 0, 23, 0, 0, 0, -35,
17                   0, 76, 0, -41, 0, 0, 21, 0, 5, 0, 5, 0, 0, 0, 5, 0, -15, 0, 5,
18                   0, 5, 0, -115, 0, 115, 0, 5, 0, -15, 0, 5, 0, 5, 0, 0, 0, 5, 0,
19                   -59, 0, 44, 0, 5, 0, 5, 0, 0, 0, 5, 0, -65, 50, 0, 5, 0, 5, 0, 0,
20                   0, 5, 0]
21     sd = 5 # noise standard deviation
22
23     def __init__(self):
24         """paper buying agent"""
25         self.time=0
26         self.stock=20
27         self.stock_history = [] # memory of the stock history
28         self.price_history = [] # memory of the price history
29
30     def initial_percept(self):
31         """return initial percept"""
32         self.stock_history.append(self.stock)
33         self.price = round(234+self.sd*random.gauss(0,1))
34         self.price_history.append(self.price)
35         return {'price': self.price,
36                'instock': self.stock}
37
38     def do(self, action):
39         """does action (buy) and returns percept consisting of price and
40            instock"""
41         used = select_from_dist({6:0.1, 5:0.1, 4:0.1, 3:0.3, 2:0.2, 1:0.2})
42         # used = select_from_dist({7:0.1, 6:0.2, 5:0.2, 4:0.3, 3:0.1,
43            2:0.1}) # uses more paper
44         bought = action['buy']
45         self.stock = self.stock+bought-used
46         self.stock_history.append(self.stock)
47         self.time += 1
48         self.price = round(self.price
49                            + self.price_delta[self.time%len(self.price_delta)] #
50                            repeating pattern
51                            + self.sd*random.gauss(0,1)) # plus randomness
52         self.price_history.append(self.price)
53         return {'price': self.price,
54                'instock': self.stock}

```

2.2.2 The Agent

The agent does not have access to the price model but can only observe the current price and the amount in stock. It has to decide how much to buy.

The belief state of the agent is an estimate of the average price of the paper, and the total amount of money the agent has spent.

agentBuying.py — (continued)

```

53 class TP_agent(Agent):
54     def __init__(self):
55         self.spent = 0
56         percept = env.initial_percept()
57         self.ave = self.last_price = percept['price']
58         self.instock = percept['instock']
59         self.buy_history = []
60
61     def select_action(self, percept):
62         """return next action to carry out
63         """
64         self.last_price = percept['price']
65         self.ave = self.ave+(self.last_price-self.ave)*0.05
66         self.instock = percept['instock']
67         if self.last_price < 0.9*self.ave and self.instock < 60:
68             tobuy = 48
69         elif self.instock < 12:
70             tobuy = 12
71         else:
72             tobuy = 0
73         self.spent += tobuy*self.last_price
74         self.buy_history.append(tobuy)
75         return {'buy': tobuy}

```

Set up an environment and an agent. Uncomment the last lines to run the agent for 90 steps, and determine the average amount spent.

```

agentBuying.py — (continued)
77 env = TP_env()
78 ag = TP_agent()
79 sim = Simulate(ag,env)
80 #sim.go(90)
81 #ag.spent/env.time ## average spent per time period

```

2.2.3 Plotting

The following plots the price and number in stock history:

```

agentBuying.py — (continued)
83 import matplotlib.pyplot as plt
84
85 class Plot_history(object):
86     """Set up the plot for history of price and number in stock"""
87     def __init__(self, ag, env):
88         self.ag = ag
89         self.env = env
90         plt.ion()
91         fig, self.ax = plt.subplots()
92         self.ax.set_xlabel("Time")
93         self.ax.set_ylabel("Value")

```

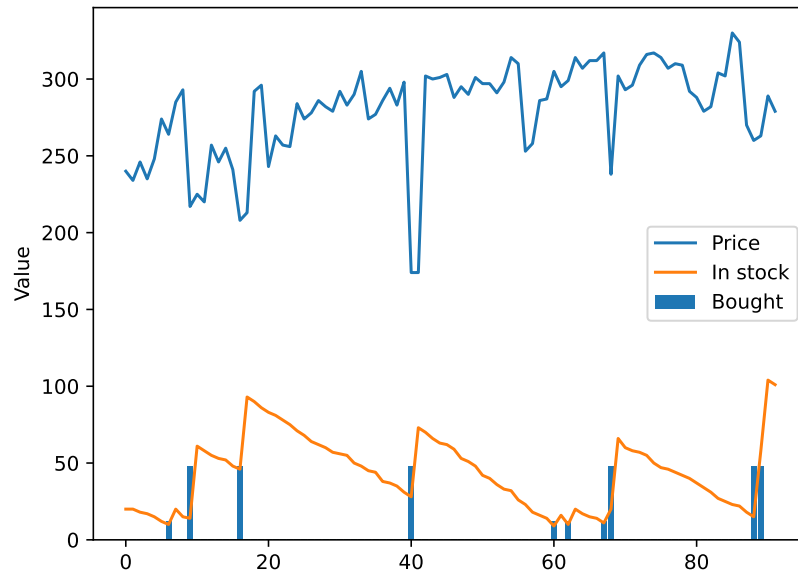

Figure 2.1: Percept and command traces for the paper-buying agent

```

94
95     def plot_env_hist(self):
96         """plot history of price and instock"""
97         num = len(env.stock_history)
98         self.ax.plot(range(num), env.price_history, label="Price")
99         self.ax.plot(range(num), env.stock_history, label="In stock")
100        self.ax.legend()
101
102     def plot_agent_hist(self):
103         """plot history of buying"""
104         num = len(ag.buy_history)
105         self.ax.bar(range(1, num+1), ag.buy_history, label="Bought")
106         self.ax.legend()
107
108 # sim.go(100); print(f"agent spent ${ag.spent/100}")
109 # pl = Plot_history(ag, env); pl.plot_env_hist(); pl.plot_agent_hist()

```

Figure 2.1 shows the result of the plotting in the previous code.

Exercise 2.1 Design a better controller for a paper-buying agent.

- Justify a performance measure that is a fair comparison. Note that minimizing the total amount of money spent may be unfair to agents who have built up a stockpile, and favors agents that end up with no paper.
- Give a controller that can work for many different price histories. An agent can use other local state variables, but does not have access to the environment model.

- Is it worthwhile trying to infer the amount of paper that the home uses? (Try your controller with the different paper consumption commented out in `TP_env.do`.)

2.3 Hierarchical Controller

To run the hierarchical controller, in folder "aipython", load "agentTop.py", using e.g., `ipython -i agentTop.py`, and copy and paste the commands near the bottom of that file.

In this implementation, each layer, including the top layer, implements the environment class, because each layer is seen as an environment from the layer above.

The robot controller is decomposed as follows. The world defines the walls. The body describes the robot's position, and its physical abilities such as whether its whisker sensor is on. The body can be told to steer left or right or to go straight. The middle layer can be told to go to x - y positions, avoiding walls. The top layer knows about named locations, such as the storage room and location `o103`, and their x - y positions. It can be told a sequence of locations, and tells the middle layer to go to the positions of the locations in turn.

2.3.1 Body

`Rob_body` defines everything about the agent body, its position and orientation and whether its whisker sensor is on. It implements the `Environment` class as it is treated as an environment by the higher layers. It can be told to turn left or right or to go straight.

```

agentEnv.py — Agent environment
11 import math
12 from agents import Environment
13 import matplotlib.pyplot as plt
14 import time
15
16 class Rob_body(Environment):
17     def __init__(self, world, init_pos=(0,0), init_dir=90):
18         """ world is the current world
19             init_pos is a pair of (x-position, y-position)
20             init_dir is a direction in degrees; 0 is to right, 90 is
                straight-up, etc
21         """
22         self.world = world
23         self.rob_pos = init_pos
24         self.rob_dir = init_dir
25         self.turning_angle = 18 # degrees that a left makes
26         self.whisker_length = 6 # length of the whisker
27         self.whisker_angle = 30 # angle of whisker relative to robot

```

```

28     self.crashed = False
29
30     def percept(self):
31         return {'rob_pos':self.rob_pos,
32               'rob_dir':self.rob_dir, 'whisker':self.whisker(),
33               'crashed':self.crashed}
34
35     initial_percept = percept # use percept function for initial percept too
36
37     def do(self, action):
38         """ action is {'steer':direction}
39         direction is 'left', 'right' or 'straight'.
40         Returns current percept.
41         """
42         if self.crashed:
43             return self.percept()
44         direction = action['steer']
45         compass_deriv =
46             {'left':1,'straight':0,'right':-1}[direction]*self.turning_angle
47         self.rob_dir = (self.rob_dir + compass_deriv +360)%360 # make in
48             range [0,360)
49         x,y = self.rob_pos
50         rob_pos_new = (x + math.cos(self.rob_dir*math.pi/180),
51                       y + math.sin(self.rob_dir*math.pi/180))
52         path = (self.rob_pos,rob_pos_new)
53         if any(line_segments_intersect(path,wall) for wall in
54               self.world.walls):
55             self.crashed = True
56             self.rob_pos = rob_pos_new
57             self.world.do({'rob_pos':self.rob_pos,
58                           'crashed':self.crashed, 'whisker':self.whisker()})
59         return self.percept()

```

The Boolean whisker method returns True when the the robots whisker sensor intersects with a wall.

agentEnv.py — (continued)

```

56     def whisker(self):
57         """returns true whenever the whisker sensor intersects with a wall
58         """
59         whisk_ang_world = (self.rob_dir-self.whisker_angle)*math.pi/180
60         # angle in radians in world coordinates
61         (x,y) = self.rob_pos
62         wend = (x + self.whisker_length * math.cos(whisk_ang_world),
63               y + self.whisker_length * math.sin(whisk_ang_world))
64         whisker_line = (self.rob_pos, wend)
65         hit = any(line_segments_intersect(whisker_line,wall)
66                 for wall in self.world.walls)
67         return hit
68
69     def line_segments_intersect(linea, lineb):
70         """returns true if the line segments, linea and lineb intersect.

```

```

71 | A line segment is represented as a pair of points.
72 | A point is represented as a (x,y) pair.
73 | """
74 | ((x0a,y0a),(x1a,y1a)) = linea
75 | ((x0b,y0b),(x1b,y1b)) = lineb
76 | da, db = x1a-x0a, x1b-x0b
77 | ea, eb = y1a-y0a, y1b-y0b
78 | denom = db*ea-eb*da
79 | if denom==0: # line segments are parallel
80 |     return False
81 | cb = (da*(y0b-y0a)-ea*(x0b-x0a))/denom # intersect along line b
82 | if cb<0 or cb>1:
83 |     return False # intersect is outside line segment b
84 | ca = (db*(y0b-y0a)-eb*(x0b-x0a))/denom # intersect along line a
85 | return 0<=ca<=1 # intersect is inside both line segments
86 |
87 | # Test cases:
88 | # assert line_segments_intersect(((0,0),(1,1)),((1,0),(0,1)))
89 | # assert not line_segments_intersect(((0,0),(1,1)),((1,0),(0.6,0.4)))
90 | # assert line_segments_intersect(((0,0),(1,1)),((1,0),(0.4,0.6)))

```

2.3.2 Middle Layer

The middle layer acts like both a controller (for the body layer) and an environment for the upper layer. It has to tell the body how to steer. Thus it calls *env.do(·)*, where *env* is the body. It implements *do(\cdot)* for the top layer, where the action specifies an *x-y* position to go to and a timeout.

```

agentMiddle.py — Middle Layer
11 | from agents import Environment
12 | import math
13 |
14 | class Rob_middle_layer(Environment):
15 |     def __init__(self, lower):
16 |         """The lower-level for the middle layer is the body.
17 |         """
18 |         self.lower = lower
19 |         self.percept = lower.initial_percept()
20 |         self.straight_angle = 11 # angle that is close enough to straight
21 |         ahead
22 |         self.close_threshold = 1 # distance that is close enough to arrived
23 |         self.close_threshold_squared = self.close_threshold**2 # just
24 |         compute it once
25 |
26 |     def initial_percept(self):
27 |         return {}
28 |
29 |     def do(self, action):
30 |         """action is {'go_to':target_pos,'timeout':timeout}

```

```

29     target_pos is (x,y) pair
30     timeout is the number of steps to try
31     returns {'arrived':True} when arrived is true
32         or {'arrived':False} if it reached the timeout
33     """
34     if 'timeout' in action:
35         remaining = action['timeout']
36     else:
37         remaining = -1 # will never reach 0
38     target_pos = action['go_to']
39     arrived = self.close_enough(target_pos)
40     while not arrived and remaining != 0:
41         self.percept = self.lower.do({"steer":self.steer(target_pos)})
42         remaining -= 1
43         arrived = self.close_enough(target_pos)
44     return {'arrived':arrived}

```

The following method determines how to steer depending on whether the goal is to the right or the left of where the robot is facing.

```

agentMiddle.py — (continued)
46     def steer(self, target_pos):
47         if self.percept['whisker']:
48             self.display(3,'whisker on', self.percept)
49             return "left"
50         else:
51             return self.head_towards(target_pos)
52
53     def head_towards(self, target_pos):
54         """ given a target position, return the action that heads
55             towards that position
56         """
57         gx,gy = target_pos
58         rx,ry = self.percept['rob_pos']
59         goal_dir = math.acos((gx-rx)/math.sqrt((gx-rx)*(gx-rx)
60             +(gy-ry)*(gy-ry)))*180/math.pi
61         if ry>gy:
62             goal_dir = -goal_dir
63         goal_from_rob = (goal_dir - self.percept['rob_dir']+540)%360-180
64         assert -180 < goal_from_rob <= 180
65         if goal_from_rob > self.straight_angle:
66             return "left"
67         elif goal_from_rob < -self.straight_angle:
68             return "right"
69         else:
70             return "straight"
71
72     def close_enough(self, target_pos):
73         """True when the robot's position is within close_threshold of
74             target_pos
75         """

```

```

74     gx,gy = target_pos
75     rx,ry = self.percept['rob_pos']
76     return (gx-rx)**2 + (gy-ry)**2 <= self.close_threshold_squared

```

2.3.3 Top Layer

The top layer treats the middle layer as its environment. Note that the top layer is an environment for us to tell it what to visit.

```

agentTop.py — Top Layer
11 from display import Displayable
12 from agentMiddle import Rob_middle_layer
13 from agents import Agent, Environment
14
15 class Rob_top_layer(Agent, Environment):
16     def __init__(self, lower, world, timeout=200 ):
17         """lower is the lower layer
18         world is the world (which knows where the locations are)
19         timeout is the number of steps the middle layer goes before giving
20         up
21         """
22         self.lower = lower
23         self.world = world
24         self.timeout = timeout # number of steps before the middle layer
25         should give up
26
27     def do(self,plan):
28         """carry out actions.
29         actions is of the form {'visit':list_of_locations}
30         It visits the locations in turn.
31         """
32         to_do = plan['visit']
33         for loc in to_do:
34             position = self.world.locations[loc]
35             arrived = self.lower.do({'go_to':position,
36                                     'timeout':self.timeout})
37             self.display(1,"Goal",loc,arrived)

```

2.3.4 World

The world defines the walls and implements tracing.

```

agentEnv.py — (continued)
92 import math
93 from display import Displayable
94 import matplotlib.pyplot as plt
95
96 class World(Environment):

```

```

97     def __init__(self, walls = {}, locations = {},
98                 plot_size=(-10,120,-10,60)):
99         """walls is a set of line segments
100            where each line segment is of the form ((x0,y0),(x1,y1))
101            locations is a loc:pos dictionary
102            where loc is a named location, and pos is an (x,y) position.
103            """
104         self.walls = walls
105         self.locations = locations
106         self.loc2text = {}
107         self.history = [] # list of (pos, whisker, crashed)
108         # The following control how it is plotted
109         plt.ion()
110         fig, self.ax = plt.subplots()
111         #self.ax.set_aspect('equal')
112         self.ax.axis(plot_size)
113         self.sleep_time = 0.05 # time between actions (for real-time
114             plotting)
115         self.draw()
116
117     def do(self, action):
118         """action is {'rob_pos':(x,y), 'whisker':Boolean, 'crashed':Boolean}
119         """
120         self.history.append((action['rob_pos'],action['whisker'],action['crashed']))
121         x,y = action['rob_pos']
122         if action['crashed']:
123             self.display(1, "*Crashed*")
124             self.ax.plot([x],[y], "r*", markersize=20.0)
125         elif action['whisker']:
126             self.ax.plot([x],[y], "ro")
127         else:
128             self.ax.plot([x],[y], "go")
129         plt.draw()
130         plt.pause(self.sleep_time)
131         return {'walls':self.walls}

```

2.3.5 Plotting

The following is used to plot the locations, the walls and (eventually) the movement of the robot. It can either plot the movement if the robot as it is going (with the default `env.plotting = True`), or not plot it as it is going (setting `env.plotting = False`; in this case the trace can be plotted using `pl.plot_run()`).

```

agentEnv.py — (continued)
131     def draw(self):
132         for wall in self.walls:
133             ((x0,y0),(x1,y1)) = wall
134             self.ax.plot([x0,x1],[y0,y1], "-k", linewidth=3)
135         for loc in self.locations:

```

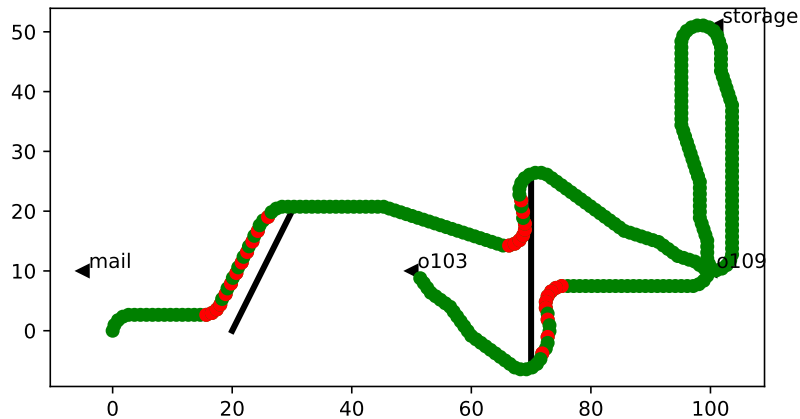

Figure 2.2: A trace of the trajectory of the agent. Red dots correspond to the whisker sensor being on; the green dot to the whisker sensor being off. The agent starts at position (0,0) facing up.

```

136         self.plot_loc(loc)
137
138     def plot_loc(self, loc):
139         (x,y) = self.locations[loc]
140         if loc in self.loc2text:
141             for e in self.loc2text[loc]:
142                 e.remove() # e.set_visible(False)
143         self.loc2text[loc] = (
144             self.ax.text(x,y,"*",ha="center",va="center",size=20),
145             self.ax.text(x+2.0,y+1,loc)) # label above and to
146                                     the right

```

The following example shows a plot of the agent as it acts in the world. Figure 2.2 shows the result of the commented-out `top.do`

```

agentTop.py — (continued)
36 from agentEnv import Rob_body, World
37
38 def rob_ex():
39     global world, body, middle, top
40     world = World(walls = {((20,0),(30,20)), ((70,-5),(70,25))},
41                 locations = {'mail':(-5,10),
42                             'o103':(50,10),
43                             'o109':(100,10), 'storage':(101,51)})
44
45     body = Rob_body(world)
46     middle = Rob_middle_layer(body)
47     top = Rob_top_layer(middle, world)
48
49 # try:
50 # top.do({'visit':['o109', 'storage', 'o109', 'o103']})
51 # You can directly control the middle layer:

```

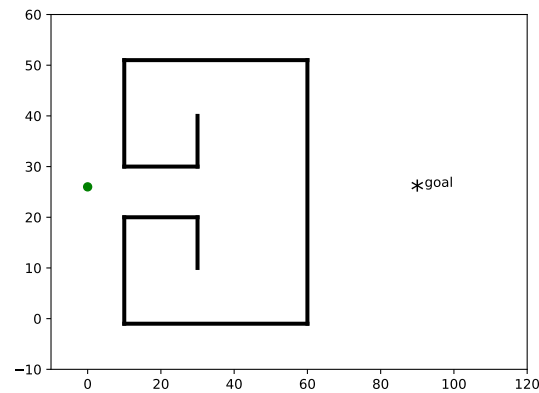

Figure 2.3: Robot trap

```

50 # middle.do({'go_to':(30,-5), 'timeout':200})
51 # Can you make it go around in circles?
52 # Can you make it crash?
53
54 if __name__ == "__main__":
55     rob_ex()
56     print("Try: top.do({'visit':['o109','storage','o109','o103']}")

```

Exercise 2.2 When does the robot go in circles? How could this be recognized and/or avoided?

Exercise 2.3 When does the agent crash? What sensor would avoid that? (Think about the worse configuration of walls.) Design a whisker-like sensor that never crashes (assuming it starts far enough from a wall) and allows the robot to go as close as possible to a wall.

Exercise 2.4 The following implements a robot trap (Figure 2.3). It is called a trap because, once it has hit the wall, it needs to follow the wall, but local features are not enough for it to know when it can head to the goal. Write a controller that can escape the “trap” and get to the goal. Would a better sensor work? See Exercise 2.4 in the textbook for hints.

agentTop.py — (continued)

```

58 # Robot Trap for which the current controller cannot escape:
59 def robot_trap():
60     global trap_world, trap_body, trap_middle, trap_top
61     trap_world = World({((10, 51), (60, 51)), ((30, 10), (30, 20)),
62                        ((10, -1), (10, 20)), ((10, 30), (10, 51)),
63                        ((30, 30), (30, 40)), ((10, -1), (60, -1)),
64                        ((10, 30), (30, 30)), ((10, 20), (30, 20)),
65                        ((60, -1), (60, 51))},
66                       locations={'goal':(90,25)})

```

```

67     trap_body = Rob_body(trap_world,init_pos=(0,25), init_dir=90)
68     trap_middle = Rob_middle_layer(trap_body)
69     trap_top = Rob_top_layer(trap_middle, trap_world)
70
71 # Robot trap exercise:
72 # robot_trap()
73 # trap_body.do({'steer':'straight'})
74 # trap_top.do({'visit':['goal']})
75 # What if the goal was further to the right?

```

Plotting for Moving Targets

Exercise 2.5 of Poole and Mackworth [2023] refers to targets that can move. The following implements targets that can be moved using the mouse. To move a target using the mouse, press on the target, move it, and release at the desired location. This can be done while the animation is running.

```

_____agentFollowTarget.py — Plotting for moving targets_____
11 import matplotlib.pyplot as plt
12 from agentEnv import Rob_body, World
13 from agentMiddle import Rob_middle_layer
14 from agentTop import Rob_top_layer
15
16 class World_follow(World):
17     def __init__(self, walls = {}, locations = {}, epsilon=5):
18         """plot the agent in the environment.
19         epsilon is the threshold how close someone needs to click to
20         select a location.
21         """
22         self.epsilon = epsilon
23         World.__init__(self, walls, locations)
24         self.canvas = self.ax.figure.canvas
25         self.canvas.mpl_connect('button_press_event', self.on_press)
26         self.canvas.mpl_connect('button_release_event', self.on_release)
27         self.canvas.mpl_connect('motion_notify_event', self.on_move)
28         self.pressloc = None
29         for loc in self.locations:
30             self.display(2,f" loc {loc} at {self.locations[loc]}")
31
32     def on_press(self, event):
33         print("press", event)
34         self.display(2, 'v',end="")
35         self.display(2,f"Press at ({event.xdata},{event.ydata}")
36         self.pressloc = None
37         if event.xdata:
38             for loc in self.locations:
39                 lx,ly = self.locations[loc]
40                 if abs(event.xdata- lx) <= self.epsilon and abs(event.ydata-
41                     ly) <= self.epsilon :

```

```

40         self.display(2,f"moving {loc} from ({event.xdata},
41                     {event.ydata})" )
42         self.pressloc = loc
43
44     def on_release(self, event):
45         self.display(2, '^',end="")
46         if self.pressloc is not None and event.xdata:
47             self.display(2,f"Placing {self.pressloc} at {(event.xdata,
48                 event.ydata)}")
49             self.locations[self.pressloc] = (event.xdata, event.ydata)
50             self.plot_loc(self.pressloc)
51             self.pressloc = None
52
53     def on_move(self, event):
54         if self.pressloc is not None and event.inaxes:
55             self.display(2, '-',end="")
56             self.locations[self.pressloc] = (event.xdata, event.ydata)
57             self.plot_loc(self.pressloc)
58         else:
59             self.display(2, '.',end="")
60
61     def rob_follow():
62         global world, body, middle, top
63         world = World_follow(walls = {(20,0),(30,20)}, ((70,-5),(70,25)}),
64                             locations = {'mail':(-5,10), 'o103':(50,10),
65                                     'o109':(100,10), 'storage':(101,51)})
66         body = Rob_body(world)
67         middle = Rob_middle_layer(body)
68         top = Rob_top_layer(middle, world)
69
70     # top.do({'visit':['o109','storage','o109','o103']})
71
72     if __name__ == "__main__":
73         rob_follow()
74         print("Try: top.do({'visit':['o109','storage','o109','o103']})")

```

Exercise 2.5 Do Exercise 2.5 of Poole and Mackworth [2023].

Exercise 2.6 Change the code to also allow walls to move.

Searching for Solutions

3.1 Representing Search Problems

A search problem consists of:

- a start node
- a *neighbors* function that given a node, returns an enumeration of the arcs from the node
- a specification of a goal in terms of a Boolean function that takes a node and returns true if the node is a goal
- a (optional) heuristic function that, given a node, returns a non-negative real number. The heuristic function defaults to zero.

As far as the searcher is concerned a node can be anything. If multiple-path pruning is used, a node must be hashable. In the simple examples, it is a string, but in more complicated examples (in later chapters) it can be a tuple, a frozen set, or a Python object.

In the following code, “raise NotImplementedError()” is a way to specify that this is an abstract method that needs to be overridden to define an actual search problem.

```
searchProblem.py — representations of search problems
11 from display import Displayable
12 import matplotlib.pyplot as plt
13 import random
14
15 class Search_problem(Displayable):
16     """A search problem consists of:
```

```

17     * a start node
18     * a neighbors function that gives the neighbors of a node
19     * a specification of a goal
20     * a (optional) heuristic function.
21     The methods must be overridden to define a search problem."""
22
23     def start_node(self):
24         """returns start node"""
25         raise NotImplementedError("start_node") # abstract method
26
27     def is_goal(self,node):
28         """is True if node is a goal"""
29         raise NotImplementedError("is_goal") # abstract method
30
31     def neighbors(self,node):
32         """returns a list (or enumeration) of the arcs for the neighbors of
33         node"""
34         raise NotImplementedError("neighbors") # abstract method
35
36     def heuristic(self,n):
37         """Gives the heuristic value of node n.
38         Returns 0 if not overridden."""
39         return 0

```

The neighbors is a list or enumeration of arcs. A (directed) arc is the pair (from_node, to_node), but can also contain a non-negative cost (which defaults to 1) and can be labeled with an action. The action is not used for the search, but is useful for displaying and for plans (sequences of of actions).

```

searchProblem.py -- (continued)
40 class Arc(object):
41     """An arc consists of
42     a from_node and a to_node node
43     a (non-negative) cost
44     an (optional) action
45     """
46     def __init__(self, from_node, to_node, cost=1, action=None):
47         self.from_node = from_node
48         self.to_node = to_node
49         self.cost = cost
50         assert cost >= 0, (f"Cost cannot be negative: {self}, cost={cost}")
51         self.action = action
52
53     def __repr__(self):
54         """string representation of an arc"""
55         if self.action:
56             return f"{self.from_node} --{self.action}--> {self.to_node}"
57         else:
58             return f"{self.from_node} --> {self.to_node}"

```

3.1.1 Explicit Representation of Search Graph

The first representation of a search problem is from an explicit graph (as opposed to one that is generated as needed).

An **explicit graph** consists of

- a list or set of nodes
- a list or set of arcs
- a start node
- a list or set of goal nodes
- (optionally) a hmap dictionary that maps a node to a heuristic value for that node. This could conceivably have been part of nodes, but the heuristic value depends on the goals.
- (optionally) a positions dictionary that maps nodes to their x - y position. This is for showing the graph visually.

To define a search problem, you need to define the start node, the goal predicate, the neighbors function and, for some algorithms, a heuristic function.

searchProblem.py — (continued)

```

60 class Search_problem_from_explicit_graph(Search_problem):
61     """A search problem from an explicit graph.
62     """
63
64     def __init__(self, title, nodes, arcs, start=None, goals=set(), hmap={},
65                 positions=None):
66         """ A search problem consists of:
67         * list or set of nodes
68         * list or set of arcs
69         * start node
70         * list or set of goal nodes
71         * hmap: dictionary that maps each node into its heuristic value.
72         * positions: dictionary that maps each node into its (x,y) position
73         """
74         self.title = title
75         self.neighs = {}
76         self.nodes = nodes
77         for node in nodes:
78             self.neighs[node]=[]
79         self.arcs = arcs
80         for arc in arcs:
81             self.neighs[arc.from_node].append(arc)
82         self.start = start
83         self.goals = goals
84         self.hmap = hmap
85         if positions is None:
```

```

86         self.positions = {node:(random.random(),random.random()) for
                        node in nodes}
87     else:
88         self.positions = positions
89
90     def start_node(self):
91         """returns start node"""
92         return self.start
93
94     def is_goal(self,node):
95         """is True if node is a goal"""
96         return node in self.goals
97
98     def neighbors(self,node):
99         """returns the neighbors of node (a list of arcs)"""
100        return self.neighs[node]
101
102    def heuristic(self,node):
103        """Gives the heuristic value of node n.
104        Returns 0 if not overridden in the hmap."""
105        if node in self.hmap:
106            return self.hmap[node]
107        else:
108            return 0
109
110    def __repr__(self):
111        """returns a string representation of the search problem"""
112        res=""
113        for arc in self.arcs:
114            res += f"{arc}. "
115        return res

```

Graphical Display of a Search Graph

The `show()` method displays the graph, and is used for the figures in this document.

```

searchProblem.py — (continued)
117    def show(self, fontsize=10, node_color='orange', show_costs = True):
118        """Show the graph as a figure
119        """
120        self.fontsize = fontsize
121        self.show_costs = show_costs
122        plt.ion() # interactive
123        fig, ax = plt.subplots()
124        ax.set_axis_off()
125        ax.set_title(self.title, fontsize=fontsize)
126        self.show_graph(ax, node_color)
127
128    def show_graph(self, ax, node_color='orange'):

```

```

129     bbox =
130         dict(boxstyle="round4,pad=1.0,rounding_size=0.5",facecolor=node_color)
131     for arc in self.arcs:
132         self.show_arc(ax, arc)
133     for node in self.nodes:
134         self.show_node(ax, node, node_color = node_color)
135
136     def show_node(self, ax, node, node_color):
137         x,y = self.positions[node]
138         ax.text(x,y,node,bbox=dict(boxstyle="round4,pad=1.0,rounding_size=0.5",
139                                 facecolor=node_color),
140                ha='center',va='center', fontsize=self.fontsize)
141
142     def show_arc(self, ax, arc, arc_color='black', node_color='white'):
143         from_pos = self.positions[arc.from_node]
144         to_pos = self.positions[arc.to_node]
145         ax.annotate(arc.to_node, from_pos, xytext=to_pos,
146                    arrowprops={'arrowstyle':'<|-', 'linewidth': 2,
147                                'color':arc_color},
148                    bbox=dict(boxstyle="round4,pad=1.0,rounding_size=0.5",
149                                facecolor=node_color),
150                    ha='center',va='center',
151                    fontsize=self.fontsize)
152         # Add costs to middle of arcs:
153         if self.show_costs:
154             ax.text((from_pos[0]+to_pos[0])/2, (from_pos[1]+to_pos[1])/2,
155                    arc.cost, bbox=dict(pad=1,fc='w',ec='w'),
156                    ha='center',va='center',fontsize=self.fontsize)

```

3.1.2 Paths

A searcher will return a path from the start node to a goal node. A Python list is not a suitable representation for a path, as many search algorithms consider multiple paths at once, and these paths should share initial parts of the path. If we wanted to do this with Python lists, we would need to keep copying the list, which can be expensive if the list is long. An alternative representation is used here in terms of a recursive data structure that can share subparts.

A path is either:

- a node (representing a path of length 0) or
- an initial path, and an arc at the end, where the `from_node` of the arc is the node at the end of the initial path.

These cases are distinguished in the following code by having `arc=None` if the path has length 0, in which case `initial` is the node of the path. Note that we only use the most basic form of Python's `yield` for enumerations (Section 1.5.3).

searchProblem.py — (continued)

```

157 class Path(object):
158     """A path is either a node or a path followed by an arc"""
159
160     def __init__(self, initial, arc=None):
161         """initial is either a node (in which case arc is None) or
162         a path (in which case arc is an object of type Arc)"""
163         self.initial = initial
164         self.arc=arc
165         if arc is None:
166             self.cost=0
167         else:
168             self.cost = initial.cost+arc.cost
169
170     def end(self):
171         """returns the node at the end of the path"""
172         if self.arc is None:
173             return self.initial
174         else:
175             return self.arc.to_node
176
177     def nodes(self):
178         """enumerates the nodes of the path from the last element backwards
179         """
180         current = self
181         while current.arc is not None:
182             yield current.arc.to_node
183             current = current.initial
184         yield current.initial
185
186     def initial_nodes(self):
187         """enumerates the nodes for the path before the end node.
188         This calls nodes() for the initial part of the path.
189         """
190         if self.arc is not None:
191             yield from self.initial.nodes()
192
193     def __repr__(self):
194         """returns a string representation of a path"""
195         if self.arc is None:
196             return str(self.initial)
197         elif self.arc.action:
198             return f"{self.initial}\n --{self.arc.action}-->
199                 {self.arc.to_node}"
200         else:
201             return f"{self.initial} --> {self.arc.to_node}"

```

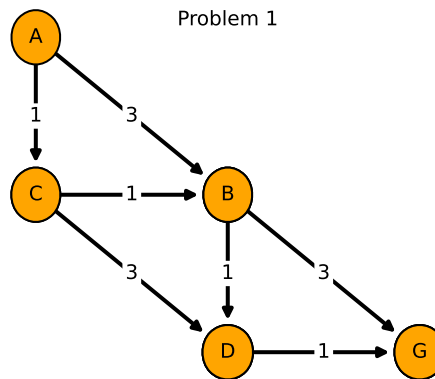

Figure 3.1: problem1

3.1.3 Example Search Problems

The first search problem is one with 5 nodes where the least-cost path is one with many arcs. See Figure 3.1, generated using `problem1.show()`. Note that this example is used for the unit tests, so the test (in `searchGeneric`) will need to be changed if this is changed.

```

searchExample.py — Search Examples
11 from searchProblem import Arc, Search_problem_from_explicit_graph,
    Search_problem
12
13 problem1 = Search_problem_from_explicit_graph('Problem 1',
14     {'A', 'B', 'C', 'D', 'G'},
15     [Arc('A', 'B', 3), Arc('A', 'C', 1), Arc('B', 'D', 1), Arc('B', 'G', 3),
16         Arc('C', 'B', 1), Arc('C', 'D', 3), Arc('D', 'G', 1)],
17     start = 'A',
18     goals = {'G'},
19     positions={'A': (0, 1), 'B': (0.5, 0.5), 'C': (0, 0.5),
20         'D': (0.5, 0), 'G': (1, 0)})

```

The second search problem is one with 8 nodes where many paths do not lead to the goal. See Figure 3.2.

```

searchExample.py — (continued)
22 problem2 = Search_problem_from_explicit_graph('Problem 2',
23     {'A', 'B', 'C', 'D', 'E', 'G', 'H', 'J'},
24     [Arc('A', 'B', 1), Arc('B', 'C', 3), Arc('B', 'D', 1), Arc('D', 'E', 3),
25         Arc('D', 'G', 1), Arc('A', 'H', 3), Arc('H', 'J', 1)],
26     start = 'A',
27     goals = {'G'},
28     positions={'A': (0, 1), 'B': (0, 3/4), 'C': (0, 0), 'D': (1/4, 3/4),
29         'E': (1/4, 0), 'G': (2/4, 3/4), 'H': (3/4, 1), 'J': (3/4, 3/4)})

```

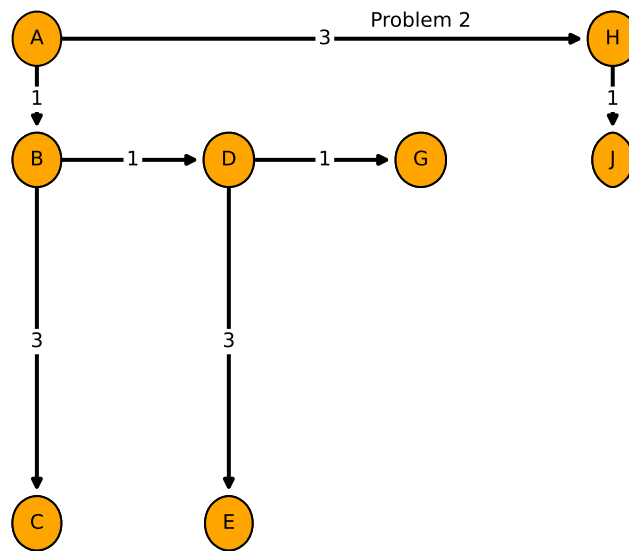

Figure 3.2: problem2

The third search problem is a disconnected graph (contains no arcs), where the start node is a goal node. This is a boundary case to make sure that weird cases work.

searchExample.py — (continued)

```

31 problem3 = Search_problem_from_explicit_graph('Problem 3',
32     {'a','b','c','d','e','g','h','j'},
33     [],
34     start = 'g',
35     goals = {'k','g'})
  
```

The simp_delivery_graph is shown Figure 3.3. This is the same as Figure 3.3 of Poole and Mackworth [2023].

searchExample.py — (continued)

```

37 simp_delivery_graph = Search_problem_from_explicit_graph("Acyclic Delivery
38     Graph",
39     {'A', 'B', 'C', 'D', 'E', 'F', 'G', 'H', 'J'},
40     [
41         Arc('A', 'B', 2),
42         Arc('A', 'C', 3),
43         Arc('A', 'D', 4),
44         Arc('B', 'E', 2),
45         Arc('B', 'F', 3),
46         Arc('C', 'J', 7),
47         Arc('D', 'H', 4),
48         Arc('F', 'D', 2),
  
```

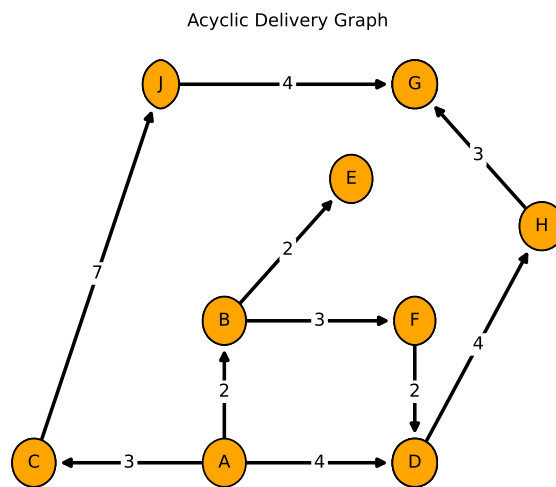
Figure 3.3: `simp_delivery_graph.show()`

```

47     Arc('H', 'G', 3),
48     Arc('J', 'G', 4)],
49 start = 'A',
50 goals = {'G'},
51 hmap = {
52     'A': 7,
53     'B': 5,
54     'C': 9,
55     'D': 6,
56     'E': 3,
57     'F': 5,
58     'G': 0,
59     'H': 3,
60     'J': 4,
61 },
62 positions = {
63     'A': (0.4,0.1),
64     'B': (0.4,0.4),
65     'C': (0.1,0.1),
66     'D': (0.7,0.1),
67     'E': (0.6,0.7),
68     'F': (0.7,0.4),
69     'G': (0.7,0.9),
70     'H': (0.9,0.6),
71     'J': (0.3,0.9)
72 }

```

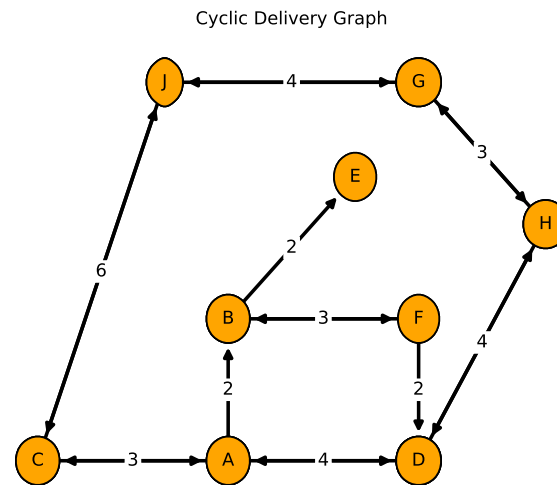
Figure 3.4: `cyclic_simp_delivery_graph.show()`

73 |)

`cyclic_simp_delivery_graph` is the graph shown Figure 3.4. This is the graph of Figure 3.10 of [Poole and Mackworth, 2023]. The heuristic values are the same as in `simp_delivery_graph`.

searchExample.py — (continued)

```

74 cyclic_simp_delivery_graph = Search_problem_from_explicit_graph("Cyclic
    Delivery Graph",
75     {'A', 'B', 'C', 'D', 'E', 'F', 'G', 'H', 'J'},
76     [
77         Arc('A', 'B', 2),
78         Arc('A', 'C', 3),
79         Arc('A', 'D', 4),
80         Arc('B', 'E', 2),
81         Arc('B', 'F', 3),
82         Arc('C', 'A', 3),
83         Arc('C', 'J', 6),
84         Arc('D', 'A', 4),
85         Arc('D', 'H', 4),
86         Arc('F', 'B', 3),
87         Arc('F', 'D', 2),
88         Arc('G', 'H', 3),
89         Arc('G', 'J', 4),
90         Arc('H', 'D', 4),
91         Arc('H', 'G', 3),
92         Arc('J', 'C', 6),
93         Arc('J', 'G', 4)],

```

```

93     start = 'A',
94     goals = {'G'},
95     hmap = {
96         'A': 7,
97         'B': 5,
98         'C': 9,
99         'D': 6,
100        'E': 3,
101        'F': 5,
102        'G': 0,
103        'H': 3,
104        'J': 4,
105    },
106    positions = {
107        'A': (0.4,0.1),
108        'B': (0.4,0.4),
109        'C': (0.1,0.1),
110        'D': (0.7,0.1),
111        'E': (0.6,0.7),
112        'F': (0.7,0.4),
113        'G': (0.7,0.9),
114        'H': (0.9,0.6),
115        'J': (0.3,0.9)
116    })

```

The next problem is the tree graph shown in Figure 3.5, and is Figure 3.15 in Poole and Mackworth [2023].

```

searchExample.py — (continued)
118 tree_graph = Search_problem_from_explicit_graph("Tree Graph",
119     {'A', 'B', 'C', 'D', 'E', 'F', 'G', 'H', 'I', 'J', 'K', 'L', 'M', 'N',
120     'O',
121     'P', 'Q', 'R', 'S', 'T', 'U', 'V', 'W', 'X', 'Y', 'Z', 'AA', 'BB',
122     'CC',
123     'DD', 'EE', 'FF', 'GG', 'HH', 'II', 'JJ', 'KK'},
124     [ Arc('A', 'B', 1),
125     Arc('A', 'C', 1),
126     Arc('B', 'D', 1),
127     Arc('B', 'E', 1),
128     Arc('C', 'F', 1),
129     Arc('C', 'G', 1),
130     Arc('D', 'H', 1),
131     Arc('D', 'I', 1),
132     Arc('E', 'J', 1),
133     Arc('E', 'K', 1),
134     Arc('F', 'L', 1),
135     Arc('G', 'M', 1),
136     Arc('G', 'N', 1),
137     Arc('H', 'O', 1),
138     Arc('H', 'P', 1),
139     Arc('J', 'Q', 1),

```

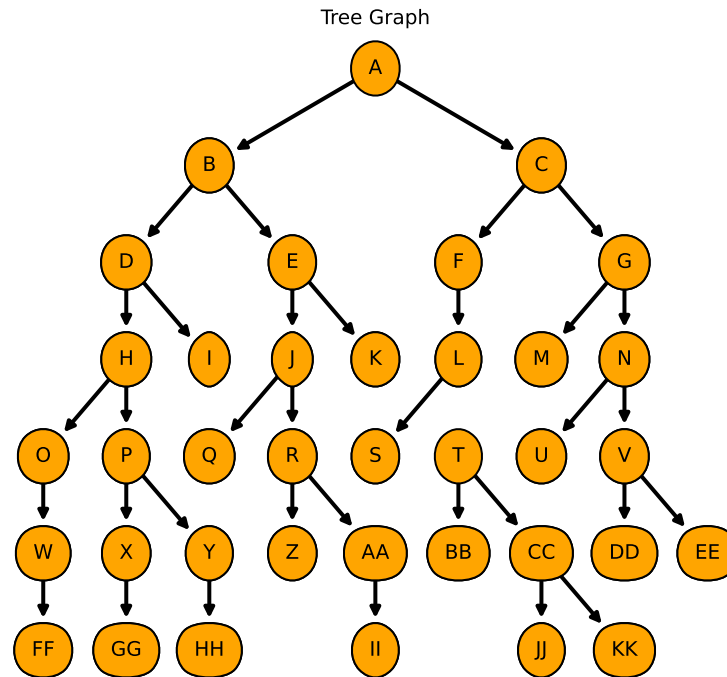
Figure 3.5: `tree_graph.show(show_costs = False)`

```

138 |     Arc('J', 'R', 1),
139 |     Arc('L', 'S', 1),
140 |     Arc('L', 'T', 1),
141 |     Arc('N', 'U', 1),
142 |     Arc('N', 'V', 1),
143 |     Arc('O', 'W', 1),
144 |     Arc('P', 'X', 1),
145 |     Arc('P', 'Y', 1),
146 |     Arc('R', 'Z', 1),
147 |     Arc('R', 'AA', 1),
148 |     Arc('T', 'BB', 1),
149 |     Arc('T', 'CC', 1),
150 |     Arc('V', 'DD', 1),
151 |     Arc('V', 'EE', 1),
152 |     Arc('W', 'FF', 1),
153 |     Arc('X', 'GG', 1),
154 |     Arc('Y', 'HH', 1),
155 |     Arc('AA', 'II', 1),

```

```
156         Arc('CC', 'JJ', 1),
157         Arc('CC', 'KK', 1)
158     ],
159     start = 'A',
160     goals = {'K', 'M', 'T', 'X', 'Z', 'HH'},
161     positions = {
162         'A': (0.5,0.95),
163         'B': (0.3,0.8),
164         'C': (0.7,0.8),
165         'D': (0.2,0.65),
166         'E': (0.4,0.65),
167         'F': (0.6,0.65),
168         'G': (0.8,0.65),
169         'H': (0.2,0.5),
170         'I': (0.3,0.5),
171         'J': (0.4,0.5),
172         'K': (0.5,0.5),
173         'L': (0.6,0.5),
174         'M': (0.7,0.5),
175         'N': (0.8,0.5),
176         'O': (0.1,0.35),
177         'P': (0.2,0.35),
178         'Q': (0.3,0.35),
179         'R': (0.4,0.35),
180         'S': (0.5,0.35),
181         'T': (0.6,0.35),
182         'U': (0.7,0.35),
183         'V': (0.8,0.35),
184         'W': (0.1,0.2),
185         'X': (0.2,0.2),
186         'Y': (0.3,0.2),
187         'Z': (0.4,0.2),
188         'AA': (0.5,0.2),
189         'BB': (0.6,0.2),
190         'CC': (0.7,0.2),
191         'DD': (0.8,0.2),
192         'EE': (0.9,0.2),
193         'FF': (0.1,0.05),
194         'GG': (0.2,0.05),
195         'HH': (0.3,0.05),
196         'II': (0.5,0.05),
197         'JJ': (0.7,0.05),
198         'KK': (0.8,0.05)
199     }
200 )
201
202 # tree_graph.show(show_costs = False)
```

3.2 Generic Searcher and Variants

To run the search demos, in folder “aipython”, load “searchGeneric.py” , using e.g., `ipython -i searchGeneric.py`, and copy and paste the example queries at the bottom of that file.

3.2.1 Searcher

A *Searcher* for a problem can be asked repeatedly for the next path. To solve a search problem, construct a *Searcher* object for the problem and then repeatedly ask for the next path using *search*. If there are no more paths, *None* is returned.

```

searchGeneric.py — Generic Searcher, including depth-first and A*
11 from display import Displayable
12
13 class Searcher(Displayable):
14     """returns a searcher for a problem.
15     Paths can be found by repeatedly calling search().
16     This does depth-first search unless overridden
17     """
18     def __init__(self, problem):
19         """creates a searcher from a problem
20         """
21         self.problem = problem
22         self.initialize_frontier()
23         self.num_expanded = 0
24         self.add_to_frontier(Path(problem.start_node()))
25         super().__init__()
26
27     def initialize_frontier(self):
28         self.frontier = []
29
30     def empty_frontier(self):
31         return self.frontier == []
32
33     def add_to_frontier(self, path):
34         self.frontier.append(path)
35
36     def search(self):
37         """returns (next) path from the problem's start node
38         to a goal node.
39         Returns None if no path exists.
40         """
41         while not self.empty_frontier():
42             self.path = self.frontier.pop()
43             self.num_expanded += 1
44             if self.problem.is_goal(self.path.end()): # solution found
45                 self.solution = self.path # store the solution found

```

```

46         self.display(1, f"Solution: {self.path} (cost:
47             {self.path.cost})\n",
48             self.num_expanded, "paths have been expanded and",
49             len(self.frontier), "paths remain in the
50             frontier")
51         return self.path
52     else:
53         self.display(4, f"Expanding: {self.path} (cost:
54             {self.path.cost}")
55         neighs = self.problem.neighbors(self.path.end())
56         self.display(2, f"Expanding: {self.path} with neighbors
57             {neighs}")
58         for arc in reversed(list(neighs)):
59             self.add_to_frontier(Path(self.path, arc))
60         self.display(3, f"New frontier: {[p.end() for p in
61             self.frontier]}")
62
63     self.display(0, "No (more) solutions. Total of",
64                 self.num_expanded, "paths expanded.")

```

Note that this reverses the neighbors so that it implements depth-first search in an intuitive manner (expanding the first neighbor first). The call to *list* is for the case when the neighbors are generated (and not already in a list). Reversing the neighbors might not be required for other methods. The calls to *reversed* and *list* can be removed, and the algorithm still implements depth-first search.

To use depth-first search to find multiple paths for `problem1` and `simp_delivery_graph`, copy and paste the following into Python's read-evaluate-print loop; keep finding next solutions until there are no more:

```

-----searchGeneric.py --- (continued) -----
61 # Depth-first search for problem1:
62 # searcher1 = Searcher(searchExample.problem1)
63 # searcher1.search() # find first solution
64 # searcher1.search() # find next solution (repeat until no solutions)
65
66 # Depth-first search for simple delivery graph:
67 # searcher_sdg = Searcher(searchExample.simp_delivery_graph)
68 # searcher_sdg.search() # find first or next solution

```

Exercise 3.1 Implement breadth-first search. Only *add_to_frontier* and/or *pop* need to be modified to implement a first-in first-out queue.

3.2.2 GUI for Tracing Search

[This GUI implements most of the functionality of the solve model of the now-discontinued AISpace.org search app.]

Figure 3.6 shows the GUI that can be used to step through search algorithms. Here the path $A \rightarrow B$ is being expanded, and the neighbors are E and F . The other nodes at the end of paths of the frontier are C and D . Thus the

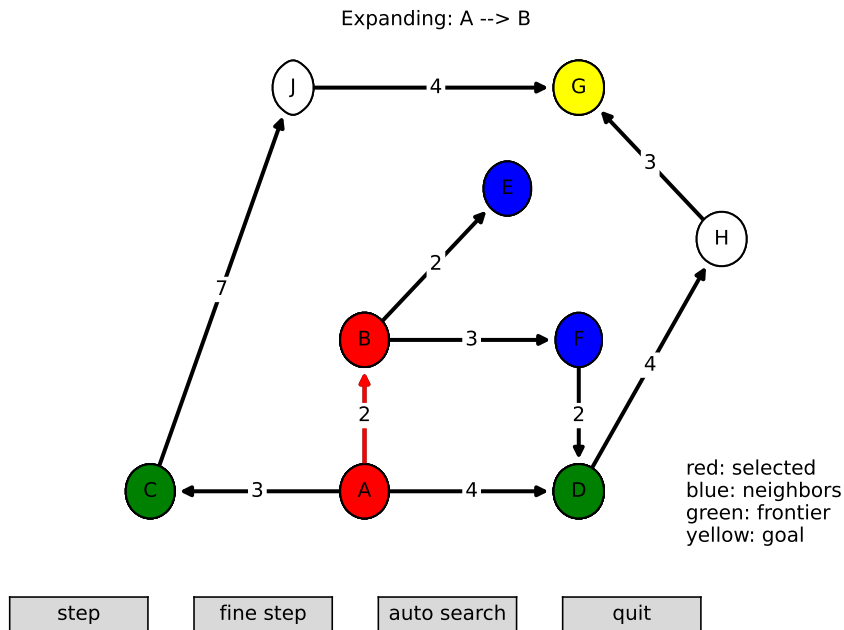

Figure 3.6: SearcherGUI(Searcher, simp_delivery_graph)

frontier contains paths to C and D , used to also contain $A \rightarrow B$, and now will contain $A \rightarrow B \rightarrow E$ and $A \rightarrow B \rightarrow F$.

SearcherGUI takes a search class and a problem, and lets one explore the search space after calling `go()`. A GUI can only be used for one search; at the end of the search the loop ends and the buttons no longer work.

This is implemented by redefining `display`. The search algorithms don't need to be modified. If you modify them (or create your own), you just have to be careful to use the appropriate number for the display. The first argument to `display` has the following meanings:

1. a solution has been found
2. what is shown for a "step" on a GUI; here it is assumed to be the path, the neighbors of the end of the path, and the other nodes at the end of paths on the frontier
3. (shown with "fine step" but not with "step") the frontier and the path selected
4. (shown with "fine step" but not with "step") the frontier.

It is also useful to look at the Python console, as the display information is printed there.

```

searchGUI.py — GUI for search
11 import matplotlib.pyplot as plt
12 from matplotlib.widgets import Button
13 import time
14
15 class SearcherGUI(object):
16     def __init__(self, SearchClass, problem,
17                 fontsize=10,
18                 colors = {'selected':'red', 'neighbors':'blue',
19                           'frontier':'green', 'goal':'yellow'},
20                 show_costs = True):
21         self.problem = problem
22         self.searcher = SearchClass(problem)
23         self.problem.fontsize = fontsize
24         self.colors = colors
25         self.problem.show_costs = show_costs
26         self.quitting = False
27
28         fig, self.ax = plt.subplots()
29         plt.ion() # interactive
30         self.ax.set_axis_off()
31         plt.subplots_adjust(bottom=0.15)
32         step_but = Button(fig.add_axes([0.1,0.02,0.2,0.05]), "step")
33         step_but.on_clicked(self.step)
34         fine_but = Button(fig.add_axes([0.4,0.02,0.2,0.05]), "fine step")
35         fine_but.on_clicked(self.finestep)
36         auto_but = Button(fig.add_axes([0.7,0.02,0.2,0.05]), "auto search")
37         auto_but.on_clicked(self.auto)
38         fig.canvas.mpl_connect('close_event', self.window_closed)
39         self.ax.text(0.85,0, '\n'.join(self.colors[a]+"'": "+a
40                                     for a in self.colors))
41         self.problem.show_graph(self.ax, node_color='white')
42         self.problem.show_node(self.ax, self.problem.start,
43                               self.colors['frontier'])
44         for node in self.problem.nodes:
45             if self.problem.is_goal(node):
46                 self.problem.show_node(self.ax, node,self.colors['goal'])
47         plt.show()
48         self.click = 7 # bigger than any display!
49         self.searcher.display = self.display
50         try:
51             while self.searcher.frontier:
52                 path = self.searcher.search()
53         except ExitToPython:
54             print("GUI closed")
55         else:
56             print("No more solutions")
57
58     def display(self, level, *args, **nargs):
59         if self.quitting:

```

```

59     raise ExitToPython()
60 if level <= self.click: #step
61     print(*args, **nargs)
62     self.ax.set_title(f"Expanding: {self.searcher.path}",
63                     fontsize=self.problem.fontsize)
64     if level == 1:
65         self.show_frontier(self.colors['frontier'])
66         self.show_path(self.colors['selected'])
67         self.ax.set_title(f"Solution Found: {self.searcher.path}",
68                         fontsize=self.problem.fontsize)
69     elif level == 2: # what should be shown if node in multiple?
70         self.show_frontier(self.colors['frontier'])
71         self.show_path(self.colors['selected'])
72         self.show_neighbors(self.colors['neighbors'])
73     elif level == 3:
74         self.show_frontier(self.colors['frontier'])
75         self.show_path(self.colors['selected'])
76     elif level == 4:
77         self.show_frontier(self.colors['frontier'])
78
79
80     # wait for a button click
81     self.click = 0
82     plt.draw()
83     while self.click == 0 and not self.quitting:
84         plt.pause(0.1)
85     if self.quitting:
86         raise ExitToPython()
87     # undo coloring:
88     self.ax.set_title("")
89     self.show_frontier('white')
90     self.show_neighbors('white')
91     path_show = self.searcher.path
92     while path_show.arc:
93         self.problem.show_arc(self.ax, path_show.arc, 'black')
94         self.problem.show_node(self.ax, path_show.end(), 'white')
95         path_show = path_show.initial
96     self.problem.show_node(self.ax, path_show.end(), 'white')
97     if self.problem.is_goal(self.searcher.path.end()):
98         self.problem.show_node(self.ax, self.searcher.path.end(),
99                               self.colors['goal'])
100     plt.draw()
101
102     def show_frontier(self, color):
103         for path in self.searcher.frontier:
104             self.problem.show_node(self.ax, path.end(), color)
105
106     def show_path(self, color):
107         """color selected path"""
108         path_show = self.searcher.path

```

```

109     while path_show.arc:
110         self.problem.show_arc(self.ax, path_show.arc, color)
111         self.problem.show_node(self.ax, path_show.end(), color)
112         path_show = path_show.initial
113         self.problem.show_node(self.ax, path_show.end(), color)
114
115     def show_neighbors(self, color):
116         for neigh in self.problem.neighbors(self.searcher.path.end()):
117             self.problem.show_node(self.ax, neigh.to_node, color)
118
119     def auto(self, event):
120         self.click = 1
121     def step(self, event):
122         self.click = 2
123     def finestep(self, event):
124         self.click = 3
125     def window_closed(self, event):
126         self.quitting = True
127
128 class ExitToPython(Exception):
129     pass

```

searchGUI.py — (continued)

```

131 from searchGeneric import Searcher, AStarSearcher
132 from searchMPP import SearcherMPP
133 import searchExample
134 from searchBranchAndBound import DF_branch_and_bound
135
136 # to demonstrate depth-first search:
137 # sdf = SearcherGUI(Searcher, searchExample.tree_graph)
138
139 # delivery graph examples:
140 # sh = SearcherGUI(Searcher, searchExample.simp_delivery_graph)
141 # sha = SearcherGUI(AStarSearcher, searchExample.simp_delivery_graph)
142 # shac = SearcherGUI(AStarSearcher,
143     searchExample.cyclic_simp_delivery_graph)
144 # shm = SearcherGUI(SearcherMPP, searchExample.cyclic_simp_delivery_graph)
145 # shb = SearcherGUI(DF_branch_and_bound, searchExample.simp_delivery_graph)
146
147 # The following is AI:FCA figure 3.15, and is useful to show branch&bound:
148 # shbt = SearcherGUI(DF_branch_and_bound, searchExample.tree_graph)
149
150 if __name__ == "__main__":
151     print("Try e.g.: SearcherGUI(Searcher,
152         searchExample.simp_delivery_graph)")

```

3.2.3 Frontier as a Priority Queue

In many of the search algorithms, such as A^* and other best-first searchers, the frontier is implemented as a priority queue. The following code uses the Python's built-in priority queue implementations, `heapq`.

Following the lead of the Python documentation, <https://docs.python.org/3/library/heapq.html>, a frontier is a list of triples. The first element of each triple is the value to be minimized. The second element is a unique index which specifies the order that the elements were added to the queue, and the third element is the path that is on the queue. The use of the unique index ensures that the priority queue implementation does not compare paths; whether one path is less than another is not defined. It also lets us control what sort of search (e.g., depth-first or breadth-first) occurs when the value to be minimized does not give a unique next path.

The variable `frontier_index` is the total number of elements of the frontier that have been created. As well as being used as the unique index, it is useful for statistics, particularly in conjunction with the current size of the frontier.

```

searchGeneric.py — (continued)
70 import heapq      # part of the Python standard library
71 from searchProblem import Path
72
73 class FrontierPQ(object):
74     """A frontier consists of a priority queue (heap), frontierpq, of
75     (value, index, path) triples, where
76     * value is the value we want to minimize (e.g., path cost + h).
77     * index is a unique index for each element
78     * path is the path on the queue
79     Note that the priority queue always returns the smallest element.
80     """
81
82     def __init__(self):
83         """constructs the frontier, initially an empty priority queue
84         """
85         self.frontier_index = 0 # the number of items added to the frontier
86         self.frontierpq = [] # the frontier priority queue
87
88     def empty(self):
89         """is True if the priority queue is empty"""
90         return self.frontierpq == []
91
92     def add(self, path, value):
93         """add a path to the priority queue
94         value is the value to be minimized"""
95         self.frontier_index += 1 # get a new unique index
96         heapq.heappush(self.frontierpq, (value, -self.frontier_index, path))
97
98     def pop(self):
99         """returns and removes the path of the frontier with minimum value.

```

```

100     """
101     (_,_,path) = heapq.heappop(self.frontierpq)
102     return path

```

The following methods are used for finding and printing information about the frontier.

```

-----searchGeneric.py --- (continued) -----
104     def count(self,val):
105         """returns the number of elements of the frontier with value=val"""
106         return sum(1 for e in self.frontierpq if e[0]==val)
107
108     def __repr__(self):
109         """string representation of the frontier"""
110         return str([(n,c,str(p)) for (n,c,p) in self.frontierpq])
111
112     def __len__(self):
113         """length of the frontier"""
114         return len(self.frontierpq)
115
116     def __iter__(self):
117         """iterate through the paths in the frontier"""
118         for (_,_,path) in self.frontierpq:
119             yield path

```

3.2.4 A* Search

For an **A* Search** the frontier is implemented using the FrontierPQ class.

```

-----searchGeneric.py --- (continued) -----
121 class AStarSearcher(Searcher):
122     """returns a searcher for a problem.
123     Paths can be found by repeatedly calling search().
124     """
125
126     def __init__(self, problem):
127         super().__init__(problem)
128
129     def initialize_frontier(self):
130         self.frontier = FrontierPQ()
131
132     def empty_frontier(self):
133         return self.frontier.empty()
134
135     def add_to_frontier(self,path):
136         """add path to the frontier with the appropriate cost"""
137         value = path.cost+self.problem.heuristic(path.end())
138         self.frontier.add(path, value)

```

Code should always be tested. The following provides a simple **unit test**, using `problem1` as the default problem.

```

searchGeneric.py — (continued)
140 import searchExample
141
142 def test(SearchClass, problem=searchExample.problem1,
143         solutions=[['G','D','B','C','A']] ):
144     """Unit test for aipython searching algorithms.
145     SearchClass is a class that takes a problem and implements search()
146     problem is a search problem
147     solutions is a list of optimal solutions
148     """
149     print("Testing problem 1:")
150     schr1 = SearchClass(problem)
151     path1 = schr1.search()
152     print("Path found:",path1)
153     assert path1 is not None, "No path is found in problem1"
154     assert list(path1.nodes()) in solutions, "Shortest path not found in
155         problem1"
156     print("Passed unit test")
157
158 if __name__ == "__main__":
159     #test(Searcher) # what needs to be changed to make this succeed?
160     test(AStarSearcher)
161
162 # example queries:
163 # searcher1 = Searcher(searchExample.simp_delivery_graph) # DFS
164 # searcher1.search() # find first path
165 # searcher1.search() # find next path
166 # searcher2 = AStarSearcher(searchExample.simp_delivery_graph) # A*
167 # searcher2.search() # find first path
168 # searcher2.search() # find next path
169 # searcher3 = Searcher(searchExample.cyclic_simp_delivery_graph) # DFS
170 # searcher3.search() # find first path with DFS. What do you expect to
171 # happen?
172 # searcher4 = AStarSearcher(searchExample.cyclic_simp_delivery_graph) # A*
173 # searcher4.search() # find first path
174
175 # To use the GUI for A* search do the following
176 # python -i searchGUI.py
177 # SearcherGUI(AStarSearcher, searchExample.simp_delivery_graph)
178 # SearcherGUI(AStarSearcher, searchExample.cyclic_simp_delivery_graph)

```

Exercise 3.2 Change the code so that it implements (i) best-first search and (ii) lowest-cost-first search. For each of these methods compare it to A^* in terms of the number of paths expanded, and the path found.

Exercise 3.3 The searcher acts like a Python iterator, in that it returns one value (here a path) and then returns other values (paths) on demand, but does not implement the iterator interface. Change the code so it implements the iterator interface. What does this enable us to do?

3.2.5 Multiple Path Pruning

To run the multiple-path pruning demo, in folder “aipython”, load “searchMPP.py”, using e.g., `ipython -i searchMPP.py`, and copy and paste the example queries at the bottom of that file.

The following implements A^* with multiple-path pruning. It overrides `search()` in `Searcher`.

```

searchMPP.py — Searcher with multiple-path pruning
11 from searchGeneric import AStarSearcher
12 from searchProblem import Path
13
14 class SearcherMPP(AStarSearcher):
15     """returns a searcher for a problem.
16     Paths can be found by repeatedly calling search().
17     """
18     def __init__(self, problem):
19         super().__init__(problem)
20         self.explored = set()
21
22     def search(self):
23         """returns next path from an element of problem's start nodes
24         to a goal node.
25         Returns None if no path exists.
26         """
27         while not self.empty_frontier():
28             self.path = self.frontier.pop()
29             if self.path.end() not in self.explored:
30                 self.explored.add(self.path.end())
31                 self.num_expanded += 1
32                 if self.problem.is_goal(self.path.end()):
33                     self.solution = self.path # store the solution found
34                     self.display(1, f"Solution: {self.path} (cost:
35                                 {self.path.cost})\n",
36                                 self.num_expanded, "paths have been expanded and",
37                                 len(self.frontier), "paths remain in the
38                                 frontier")
39                     return self.path
39                 else:
40                     self.display(4, f"Expanding: {self.path} (cost:
41                                 {self.path.cost})")
42                     neighs = self.problem.neighbors(self.path.end())
43                     self.display(2, f"Expanding: {self.path} with neighbors
44                                 {neighs}")
45                     for arc in neighs:
46                         self.add_to_frontier(Path(self.path, arc))
47                     self.display(3, f"New frontier: {[p.end() for p in
48                                 self.frontier]}")
49         self.display(0, "No (more) solutions. Total of",

```

```

46         self.num_expanded,"paths expanded.")
47
48     from searchGeneric import test
49     if __name__ == "__main__":
50         test(SearcherMPP)
51
52     import searchExample
53     # searcherMPPcdp = SearcherMPP(searchExample.cyclic_simp_delivery_graph)
54     # searcherMPPcdp.search() # find first path
55
56     # To use the GUI for SearcherMPP do
57     # python -i searchGUI.py
58     # import searchMPP
59     # SearcherGUI(searchMPP.SearcherMPP,
60                 searchExample.cyclic_simp_delivery_graph)

```

Exercise 3.4 Chris was very puzzled as to why there was a minus (“-”) in the second element of the tuple added to the heap in the add method in FrontierPQ in searchGeneric.py.

Sam suggested the following example would demonstrate the importance of the minus. Consider an infinite integer grid, where the states are pairs of integers, the start is (0,0), and the goal is (10,10). The neighbors of (i,j) are $(i+1,j)$ and $(i,j+1)$. Consider the heuristic function $h((i,j)) = |10-i| + |10-j|$. Sam suggested you compare how many paths are expanded with the minus and without the minus. searchGrid is a representation of Sam’s graph. If something takes too long, you might consider changing the size.

```

searchGrid.py — A grid problem to demonstrate A*
11 from searchProblem import Search_problem, Arc
12
13 class GridProblem(Search_problem):
14     """a node is a pair (x,y)"""
15     def __init__(self, size=10):
16         self.size = size
17
18     def start_node(self):
19         """returns the start node"""
20         return (0,0)
21
22     def is_goal(self,node):
23         """returns True when node is a goal node"""
24         return node == (self.size,self.size)
25
26     def neighbors(self,node):
27         """returns a list of the neighbors of node"""
28         (x,y) = node
29         return [Arc(node,(x+1,y)), Arc(node,(x,y+1))]
30
31     def heuristic(self,node):
32         (x,y) = node

```

```

33         return abs(x-self.size)+abs(y-self.size)
34
35     class GridProblemNH(GridProblem):
36         """Grid problem with a heuristic of 0"""
37         def heuristic(self,node):
38             return 0
39
40     from searchGeneric import Searcher, AStarSearcher
41     from searchMPP import SearcherMPP
42     from searchBranchAndBound import DF_branch_and_bound
43
44     def testGrid(size = 10):
45         print("\nWith MPP")
46         gridsearchermpp = SearcherMPP(GridProblem(size))
47         print(gridsearchermpp.search())
48         print("\nWithout MPP")
49         gridsearchera = AStarSearcher(GridProblem(size))
50         print(gridsearchera.search())
51         print("\nWith MPP and a heuristic = 0 (Dijkstra's algorithm)")
52         gridsearchermppnh = SearcherMPP(GridProblemNH(size))
53         print(gridsearchermppnh.search())

```

Explain to Chris what the minus does and why it is there. Give evidence for your claims. It might be useful to refer to other search strategies in your explanation. As part of your explanation, explain what is special about Sam’s example.

Exercise 3.5 Implement a searcher that implements cycle pruning instead of multiple-path pruning. You need to decide whether to check for cycles when paths are added to the frontier or when they are removed. (Hint: either method can be implemented by only changing one or two lines in SearcherMPP. Hint: there is a cycle if `path.end()` in `path.initial_nodes()`) Compare no pruning, multiple path pruning and cycle pruning for the cyclic delivery problem. Which works better in terms of number of paths expanded, computational time or space?

3.3 Branch-and-bound Search

To run the demo, in folder “aipython”, load “searchBranchAndBound.py”, and copy and paste the example queries at the bottom of that file.

Depth-first search methods do not need a priority queue, but can use a list as a stack. In this implementation of branch-and-bound search, we call *search* to find an optimal solution with cost less than bound. This uses depth-first search to find a path to a goal that extends *path* with cost less than the bound. Once a path to a goal has been found, that path is remembered as the *best_path*, the bound is reduced, and the search continues.

searchBranchAndBound.py — Branch and Bound Search

```
11 from searchProblem import Path
```

```

12 from searchGeneric import Searcher
13 from display import Displayable
14
15 class DF_branch_and_bound(Searcher):
16     """returns a branch and bound searcher for a problem.
17     An optimal path with cost less than bound can be found by calling
18     search()
19     """
20     def __init__(self, problem, bound=float("inf")):
21         """creates a searcher than can be used with search() to find an
22         optimal path.
23         bound gives the initial bound. By default this is infinite -
24         meaning there
25         is no initial pruning due to depth bound
26         """
27         super().__init__(problem)
28         self.best_path = None
29         self.bound = bound
30
31     def search(self):
32         """returns an optimal solution to a problem with cost less than
33         bound.
34         returns None if there is no solution with cost less than bound."""
35         self.frontier = [Path(self.problem.start_node())]
36         self.num_expanded = 0
37         while self.frontier:
38             self.path = self.frontier.pop()
39             if self.path.cost+self.problem.heuristic(self.path.end()) <
40                 self.bound:
41                 # if self.path.end() not in self.path.initial_nodes(): # for
42                 # cycle pruning
43                 self.display(2,"Expanding:",self.path,"cost:",self.path.cost)
44                 self.num_expanded += 1
45                 if self.problem.is_goal(self.path.end()):
46                     self.best_path = self.path
47                     self.bound = self.path.cost
48                     self.display(1,"New best path:",self.path,"
49                             cost:",self.path.cost)
50                 else:
51                     neighs = self.problem.neighbors(self.path.end())
52                     self.display(4,"Neighbors are", neighs)
53                     for arc in reversed(list(neighs)):
54                         self.add_to_frontier(Path(self.path, arc))
55                     self.display(3, f"New frontier: {[p.end() for p in
56                             self.frontier]}")
57         self.path = self.best_path
58         self.solution = self.best_path
59         self.display(1,f"Optimal solution is {self.best_path}." if
60             self.best_path
61             else "No solution found.",

```

```

53         f"Number of paths expanded: {self.num_expanded}."
54     return self.best_path

```

Note that this code used *reversed* in order to expand the neighbors of a node in the left-to-right order one might expect. It does this because *pop()* removes the rightmost element of the list. The call to *list* is there because *reversed* only works on lists and tuples, but the neighbors can be generated.

Here is a unit test and some queries:

```

-----searchBranchAndBound.py --- (continued) -----
56 from searchGeneric import test
57 if __name__ == "__main__":
58     test(DF_branch_and_bound)
59
60 # Example queries:
61 import searchExample
62 # searcher1 = DF_branch_and_bound(searchExample.simp_delivery_graph)
63 # searcher1.search() # find optimal path
64 # searcher2 =
65     DF_branch_and_bound(searchExample.cyclic_simp_delivery_graph,
66                           bound=100)
67 # searcher2.search() # find optimal path
68
69 # to use the GUI do:
70 # ipython -i searchGUI.py
71 # import searchBranchAndBound
72 # SearcherGUI(searchBranchAndBound.DF_branch_and_bound,
73               searchExample.simp_delivery_graph)
74 # SearcherGUI(searchBranchAndBound.DF_branch_and_bound,
75               searchExample.cyclic_simp_delivery_graph)

```

Exercise 3.6 In `searcherb2`, in the code above, what happens if the bound is smaller, say 10? What if it is larger, say 1000?

Exercise 3.7 Implement a branch-and-bound search using recursion. Hint: you don't need an explicit frontier, but can do a recursive call for the children.

Exercise 3.8 Add loop detection to branch-and-bound search.

Exercise 3.9 After the branch-and-bound search found a solution, Sam ran search again, and noticed a different count. Sam hypothesized that this count was related to the number of nodes that an A^* search would use (either expand or be added to the frontier). Or maybe, Sam thought, the count for a number of nodes when the bound is slightly above the optimal path case is related to how A^* would work. Is there a relationship between these counts? Are there different things that it could count so they are related? Try to find the most specific statement that is true, and explain why it is true.

To test the hypothesis, Sam wrote the following code, but isn't sure it is helpful:

```

-----searchTest.py --- code that may be useful to compare A* and branch-and-bound -----
11 from searchGeneric import Searcher, AStarSearcher

```

```

12 from searchBranchAndBound import DF_branch_and_bound
13 from searchMPP import SearcherMPP
14
15 DF_branch_and_bound.max_display_level = 1
16 Searcher.max_display_level = 1
17
18 def run(problem,name):
19     print("\n\n*****",name)
20
21     print("\nA*:")
22     asearcher = AStarSearcher(problem)
23     print("Path found:",asearcher.search()," cost=",asearcher.solution.cost)
24     print("there are",asearcher.frontier.count(asearcher.solution.cost),
25           "elements remaining on the queue with
26           f-value=",asearcher.solution.cost)
27
28     print("\nA* with MPP:"),
29     msearcher = SearcherMPP(problem)
30     print("Path found:",msearcher.search()," cost=",msearcher.solution.cost)
31     print("there are",msearcher.frontier.count(msearcher.solution.cost),
32           "elements remaining on the queue with
33           f-value=",msearcher.solution.cost)
34
35     bound = asearcher.solution.cost*1.00001
36     print("\nBranch and bound (with too-good initial bound of", bound,")")
37     tbb = DF_branch_and_bound(problem,bound) # cheating!!!
38     print("Path found:",tbb.search()," cost=",tbb.solution.cost)
39     print("Rerunning B&B")
40     print("Path found:",tbb.search())
41
42     bbound = asearcher.solution.cost*10+10
43     print("\nBranch and bound (with not-very-good initial bound of",
44           bbound, ")")
45     tbb2 = DF_branch_and_bound(problem,bbound)
46     print("Path found:",tbb2.search()," cost=",tbb2.solution.cost)
47     print("Rerunning B&B")
48     print("Path found:",tbb2.search())
49
50     print("\nDepth-first search: (Use ^C if it goes on forever)")
51     tsearcher = Searcher(problem)
52     print("Path found:",tsearcher.search()," cost=",tsearcher.solution.cost)
53
54 import searchExample
55 from searchTest import run
56 if __name__ == "__main__":
57     run(searchExample.problem1,"Problem 1")
58     # run(searchExample.simp_delivery_graph,"Acyclic Delivery")
59     # run(searchExample.cyclic_simp_delivery_graph,"Cyclic Delivery")
60     # also test graphs with cycles, and graphs with multiple least-cost paths

```

Reasoning with Constraints

4.1 Constraint Satisfaction Problems

4.1.1 Variables

A **variable** consists of a name, a domain and an optional (x,y) position (for displaying). The domain of a variable is a list or a tuple, as the ordering matters for some algorithms.

```
_____variable.py — Representations of a variable in CSPs and probabilistic models _____
11 import random
12
13 class Variable(object):
14     """A random variable.
15     name (string) - name of the variable
16     domain (list) - a list of the values for the variable.
17     an (x,y) position for displaying
18     """
19
20     def __init__(self, name, domain, position=None):
21         """Variable
22         name a string
23         domain a list of printable values
24         position of form (x,y) where 0 <= x <= 1, 0 <= y <= 1
25         """
26         self.name = name # string
27         self.domain = domain # list of values
28         self.position = position if position else (random.random(),
29             random.random())
29         self.size = len(domain)
30
31     def __str__(self):
```

```

32     return self.name
33
34     def __repr__(self):
35         return self.name # f"Variable({self.name})"

```

4.1.2 Constraints

A **constraint** consists of:

- A tuple (or list) of variables called the **scope**.
- A **condition**, a Boolean function that takes the same number of arguments as there are variables in the scope.
- An name (for displaying)
- An optional (x, y) position. The mean of the positions of the variables in the scope is used, if not specified.

```

_____cspProblem.py — Representations of a Constraint Satisfaction Problem_____
11 from variable import Variable
12
13 # for showing csps:
14 import matplotlib.pyplot as plt
15 import matplotlib.lines as lines
16
17 class Constraint(object):
18     """A Constraint consists of
19     * scope: a tuple or list of variables
20     * condition: a Boolean function that can applied to a tuple of values
      for variables in scope
21     * string: a string for printing the constraint
22     """
23     def __init__(self, scope, condition, string=None, position=None):
24         self.scope = scope
25         self.condition = condition
26         self.string = string
27         self.position = position
28
29     def __repr__(self):
30         return self.string

```

An **assignment** is a *variable:value* dictionary.

If con is a constraint:

- con.can_evaluate(assignment) is True when the constraint can be evaluated in the assignment. Generally this is true when all variables in the scope of the constraint are assigned in the assignment. [There are cases where it could be true when not all variables are assigned, such as if the constraint was “if x then y else z ”, but that it not implemented here.]

- `con.holds(assignment)` returns True or False depending on whether the condition is true or false for that assignment. The assignment must assign a value to every variable in the scope of the constraint `con` (and could also assign values to other variables); `con.holds` gives an error if not all variables in the scope of `con` are assigned in the assignment. It ignores variables in assignment that are not in the scope of the constraint.

In Python, the `*` notation is used for unpacking a tuple. For example, $F(*(1,2,3))$ is the same as $F(1,2,3)$. So if t has value $(1,2,3)$, then $F(*t)$ is the same as $F(1,2,3)$.

```

cspProblem.py -- (continued)
32 def can_evaluate(self, assignment):
33     """
34     assignment is a variable:value dictionary
35     returns True if the constraint can be evaluated given assignment
36     """
37     return all(v in assignment for v in self.scope)
38
39 def holds(self, assignment):
40     """returns the value of Constraint con evaluated in assignment.
41
42     precondition: all variables are assigned in assignment, ie
43                   self.can_evaluate(assignment) is true
44     """
45     return self.condition(*tuple(assignment[v] for v in self.scope))

```

4.1.3 CSPs

A constraint satisfaction problem (CSP) requires:

- title: a string title
- variables: a list or set of variables
- constraints: a set or list of constraints.

Other properties are inferred from these:

- `var_to_const` is a mapping from variables to set of constraints, such that `var_to_const[var]` is the set of constraints with `var` in their scope.

```

cspProblem.py -- (continued)
46 class CSP(object):
47     """A CSP consists of
48     * a title (a string)
49     * variables, a list or set of variables
50     * constraints, a list of constraints
51     * var_to_const, a variable to set of constraints dictionary

```

```

52     """
53     def __init__(self, title, variables, constraints):
54         """title is a string
55         variables is set of variables
56         constraints is a list of constraints
57         """
58         self.title = title
59         self.variables = variables
60         self.constraints = constraints
61         self.var_to_const = {var:set() for var in self.variables}
62         for con in constraints:
63             for var in con.scope:
64                 self.var_to_const[var].add(con)
65
66     def __str__(self):
67         """string representation of CSP"""
68         return self.title
69
70     def __repr__(self):
71         """more detailed string representation of CSP"""
72         return f"CSP({self.title}, {self.variables}, {[str(c) for c in
            self.constraints]}))"

```

`csp.consistent(assignment)` returns true if the assignment is consistent with each of the constraints in `csp` (i.e., all of the constraints that can be evaluated evaluate to true). Unless the assignment assigns to all variables, `consistent` does *not* imply the CSP is consistent or has a solution, because constraints involving variables not in the assignment are ignored.

cspProblem.py — (continued)

```

74     def consistent(self, assignment):
75         """assignment is a variable:value dictionary
76         returns True if all of the constraints that can be evaluated
77             evaluate to True given assignment.
78         """
79         return all(con.holds(assignment)
80                   for con in self.constraints
81                   if con.can_evaluate(assignment))

```

The `show` method uses `matplotlib` to show the graphical structure of a constraint network. This also includes code used for the consistency GUI (Section 4.4.2).

cspProblem.py — (continued)

```

83     def show(self, linewidth=3, showDomains=False, showAutoAC = False):
84         self.linewidth = linewidth
85         self.picked = None
86         plt.ion() # interactive
87         self.arcs = {} # arc: (con,var) dictionary
88         self.thelines = {} # (con,var):arc dictionary
89         self.nodes = {} # node: variable dictionary

```

```

90     self.fig, self.ax= plt.subplots(1, 1)
91     self.ax.set_axis_off()
92     for var in self.variables:
93         if var.position is None:
94             var.position = (random.random(), random.random())
95     self.showAutoAC = showAutoAC # used for consistency GUI
96     self.autoAC = False
97     domains = {var:var.domain for var in self.variables} if showDomains
98         else {}
99     self.draw_graph(domains=domains)
100
101 def draw_graph(self, domains={}, to_do = {}, title=None, fontsize=10):
102     self.ax.clear()
103     self.ax.set_axis_off()
104     if title:
105         self.ax.set_title(title, fontsize=fontsize)
106     else:
107         self.ax.set_title(self.title, fontsize=fontsize)
108     var_bbox = dict(boxstyle="round4,pad=1.0,rounding_size=0.5",
109                    facecolor="yellow")
110     con_bbox = dict(boxstyle="square,pad=1.0",facecolor="lightyellow")
111     self.autoACtext = self.ax.text(0,0,"Auto AC" if self.showAutoAC
112         else "",
113                                bbox={'boxstyle':'square,pad=1.0',
114                                    'facecolor':'pink'},
115                                picker=True, fontsize=fontsize)
116
117     for con in self.constraints:
118         if con.position is None:
119             con.position = tuple(sum(var.position[i] for var in
120                 con.scope)/len(con.scope)
121                                for i in range(2))
122
123         cx,cy = con.position
124         bbox = con_bbox
125         for var in con.scope:
126             vx,vy = var.position
127             if (var,con) in to_do:
128                 color = 'blue'
129             else:
130                 color = 'green'
131             line = lines.Line2D([cx,vx], [cy,vy], axes=self.ax,
132                                color=color,
133                                picker=True, pickradius=10,
134                                linewidth=self.linewidth)
135
136             self.arcs[line]= (var,con)
137             self.thelines[(var,con)] = line
138             self.ax.add_line(line)
139             self.ax.text(cx,cy,con.string,
140                        bbox=con_bbox,
141                        ha='center',va='center', fontsize=fontsize)
142     for var in self.variables:

```

```

135         x,y = var.position
136         if domains:
137             node_label = f"{var.name}\n{domains[var]}"
138         else:
139             node_label = var.name
140         node = self.ax.text(x, y, node_label, bbox=var_bbox,
141                             ha='center', va='center',
142                             picker=True, fontsize=fontsize)
143         self.fig.canvas.mpl_connect('pick_event', self.pick_handler)

```

The following method is used for the GUI (Section 4.4.2).

```

cspProblem.py — (continued)
145 def pick_handler(self,event):
146     mouseevent = event.mouseevent
147     self.last_artist = artist = event.artist
148     #print('***picker handler:',artist, 'mouseevent:', mouseevent)
149     if artist in self.arcs:
150         #print('### selected arc',self.arcs[artist])
151         self.picked = self.arcs[artist]
152     elif artist in self.nodes:
153         #print('### selected node',self.nodes[artist])
154         self.picked = self.nodes[artist]
155     elif artist==self.autoACtext:
156         self.autoAC = True
157         #print("*** autoAC")
158     else:
159         print("### unknown click")

```

4.1.4 Examples

In the following code `ne_`, when given a number, returns a function that is true when its argument is not that number. For example, if `f=ne_(3)`, then `f(2)` is True and `f(3)` is False. That is, `ne_(x)(y)` is true when $x \neq y$. Allowing a function of multiple arguments to use its arguments one at a time is called **currying**, after the logician Haskell Curry. Some alternative implementations are commented out; the uncommented one allows the partial functions to have names.

```

cspExamples.py — Example CSPs
11 from cspProblem import Variable, CSP, Constraint
12 from operator import lt,ne,eq,gt
13
14 def ne_(val):
15     """not equal value"""
16     # return lambda x: x != val # alternative definition
17     # return partial(ne,val) # another alternative definition
18     def nev(x):

```

```

19     return val != x
20     nev.__name__ = f"{val} != " # name of the function
21     return nev

```

Similarly $is_x(y)$ is true when $x = y$.

_____cspExamples.py — (continued)_____

```

23 def is_(val):
24     """is a value"""
25     # return lambda x: x == val # alternative definition
26     # return partial(eq,val) # another alternative definition
27     def isv(x):
28         return val == x
29     isv.__name__ = f"{val} == "
30     return isv

```

`csp0` has variables X , Y and Z , each with domain $\{1,2,3\}$. The constraints are $X < Y$ and $Y < Z$.

_____cspExamples.py — (continued)_____

```

32 X = Variable('X', {1,2,3}, position=(0.1,0.8))
33 Y = Variable('Y', {1,2,3}, position=(0.5,0.2))
34 Z = Variable('Z', {1,2,3}, position=(0.9,0.8))
35 csp0 = CSP("csp0", {X,Y,Z},
36           [ Constraint([X,Y], lt, "X<Y"),
37             Constraint([Y,Z], lt, "Y<Z")])

```

`csp1` has variables A , B and C , each with domain $\{1,2,3,4\}$. The constraints are $A < B$, $B \neq 2$, and $B < C$. This is slightly more interesting than `csp0` as it has more solutions. This example is used in the unit tests, and so if it is changed, the unit tests need to be changed. `csp1s` is the same, but with only the constraints $A < B$ and $B < C$

_____cspExamples.py — (continued)_____

```

39 A = Variable('A', {1,2,3,4}, position=(0.2,0.9))
40 B = Variable('B', {1,2,3,4}, position=(0.8,0.9))
41 C = Variable('C', {1,2,3,4}, position=(1,0.3))
42 C0 = Constraint([A,B], lt, "A < B", position=(0.4,0.3))
43 C1 = Constraint([B], ne_(2), "B != 2", position=(1,0.7))
44 C2 = Constraint([B,C], lt, "B < C", position=(0.6,0.1))
45 csp1 = CSP("csp1", {A, B, C},
46           [C0, C1, C2])
47
48 csp1s = CSP("csp1s", {A, B, C},
49            [C0, C2]) # A<B, B<C

```

The next CSP, `csp2` is Example 4.9 of Poole and Mackworth [2023]; the domain consistent network (after applying the unary constraints) is shown in Figure 4.2. Note that we use the same variables as the previous example and add two more.

_____cspExamples.py — (continued)_____

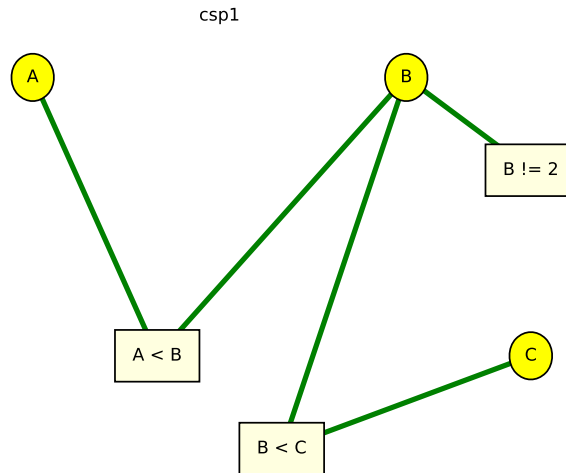
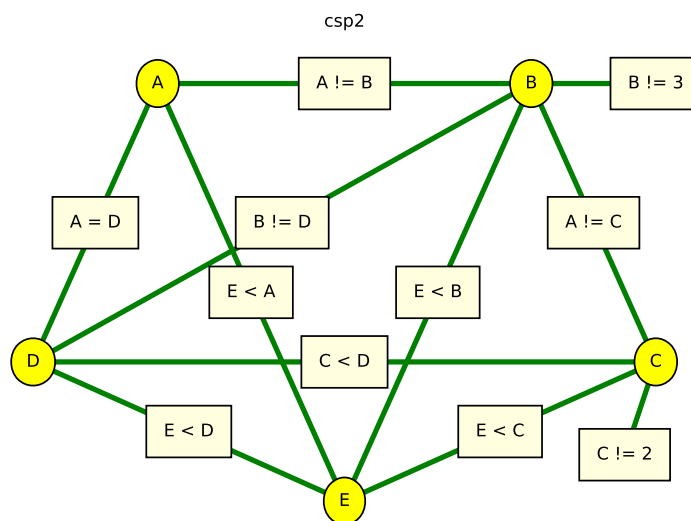
Figure 4.1: `csp1.show()`Figure 4.2: `csp2.show()`

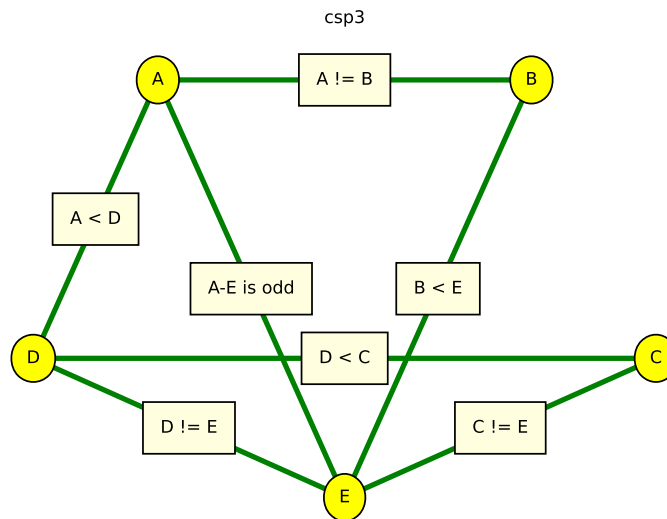

Figure 4.3: csp3.show()

```

51 D = Variable('D', {1,2,3,4}, position=(0,0.3))
52 E = Variable('E', {1,2,3,4}, position=(0.5,0))
53 csp2 = CSP("csp2", {A,B,C,D,E},
54         [ Constraint([B], ne_(3), "B != 3", position=(1,0.9)),
55           Constraint([C], ne_(2), "C != 2", position=(0.95,0.1)),
56           Constraint([A,B], ne, "A != B"),
57           Constraint([B,C], ne, "A != C"),
58           Constraint([C,D], lt, "C < D"),
59           Constraint([A,D], eq, "A = D"),
60           Constraint([E,A], lt, "E < A"),
61           Constraint([E,B], lt, "E < B"),
62           Constraint([E,C], lt, "E < C"),
63           Constraint([E,D], lt, "E < D"),
64           Constraint([B,D], ne, "B != D")]])

```

The following example is another scheduling problem (but with multiple answers). This is the same as “scheduling 2” in the original AIspace.org consistency app.

```

cspExamples.py — (continued)
66 csp3 = CSP("csp3", {A,B,C,D,E},
67         [Constraint([A,B], ne, "A != B"),
68           Constraint([A,D], lt, "A < D"),
69           Constraint([A,E], lambda a,e: (a-e)%2 == 1, "A-E is odd"),
70           Constraint([B,E], lt, "B < E"),
71           Constraint([D,C], lt, "D < C"),
72           Constraint([C,E], ne, "C != E"),

```

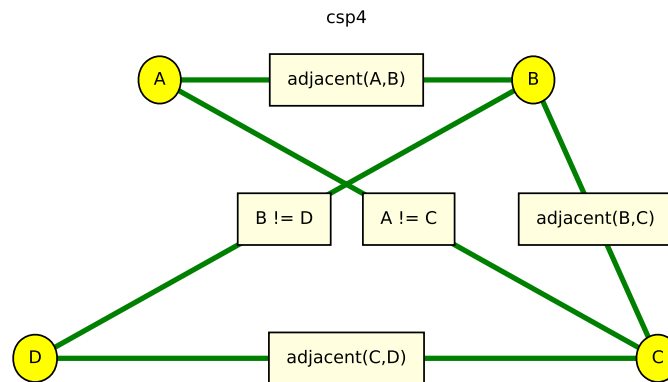

Figure 4.4: csp4.show()

```
73 |         Constraint([D,E], ne, "D != E"))]
```

The following example is another abstract scheduling problem. What are the solutions?

```
cspExamples.py — (continued)
```

```
75 def adjacent(x,y):
76     """True when x and y are adjacent numbers"""
77     return abs(x-y) == 1
78
79 csp4 = CSP("csp4", {A,B,C,D},
80           [Constraint([A,B], adjacent, "adjacent(A,B)"),
81            Constraint([B,C], adjacent, "adjacent(B,C)"),
82            Constraint([C,D], adjacent, "adjacent(C,D)"),
83            Constraint([A,C], ne, "A != C"),
84            Constraint([B,D], ne, "B != D") ])
```

The following examples represent the crossword shown in Figure 4.5.

In the first representation, the variables represent words. The constraint imposed by the crossword is that where two words intersect, the letter at the intersection must be the same. The method `meet_at` is used to test whether two words intersect with the same letter. For example, the constraint `meet_at(2,0)` means that the third letter (at position 2) of the first argument is the same as the first letter of the second argument. This is shown in Figure 4.6.

```
cspExamples.py — (continued)
```

```
86 | def meet_at(p1,p2):
```

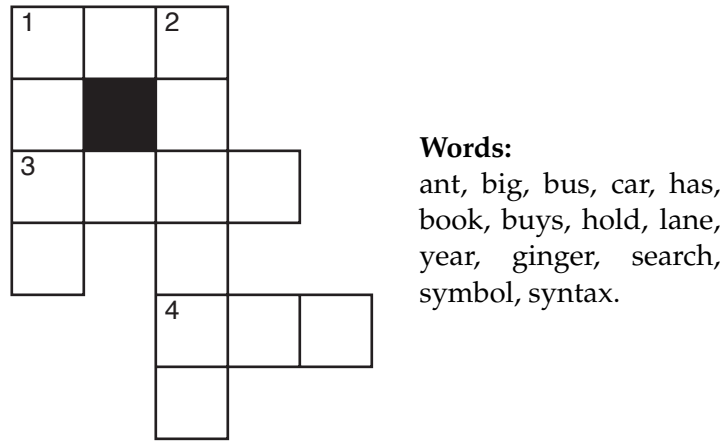

Figure 4.5: crossword1: a crossword puzzle to be solved

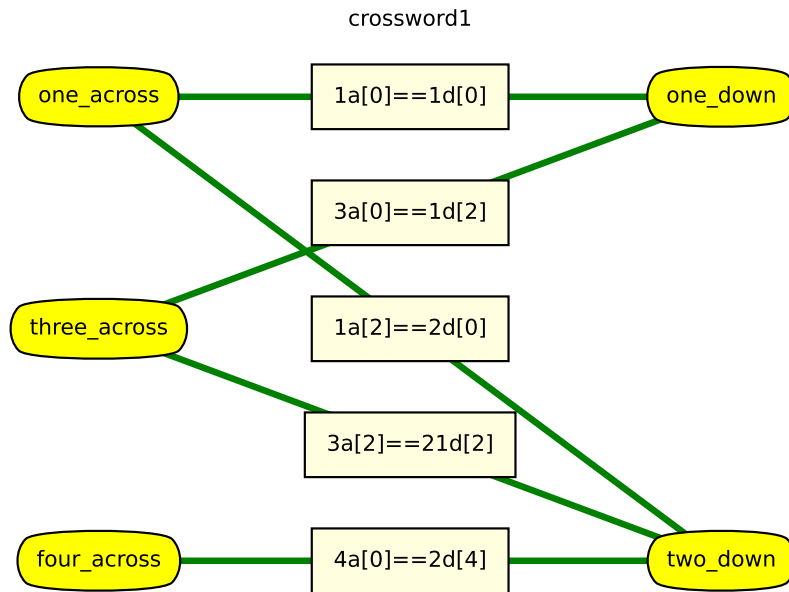

Figure 4.6: crossword1.show()

```

87     """returns a function of two words that is true
88         when the words intersect at positions p1, p2.
89     The positions are relative to the words; starting at position 0.
90     meet_at(p1,p2)(w1,w2) is true if the same letter is at position p1 of
91         word w1
92         and at position p2 of word w2.
93     """
94     def meets(w1,w2):
95         return w1[p1] == w2[p2]
96     meets.__name__ = f"meet_at({p1},{p2})"
97     return meets
98 one_across = Variable('one_across', {'ant', 'big', 'bus', 'car', 'has'},
99     position=(0.1,0.9))
100 one_down = Variable('one_down', {'book', 'buys', 'hold', 'lane', 'year'},
101     position=(0.9,0.9))
102 two_down = Variable('two_down', {'ginger', 'search', 'symbol', 'syntax'},
103     position=(0.9,0.1))
104 three_across = Variable('three_across', {'book', 'buys', 'hold', 'land',
105     'year'}, position=(0.1,0.5))
106 four_across = Variable('four_across',{ 'ant', 'big', 'bus', 'car', 'has'},
107     position=(0.1,0.1))
108 crossword1 = CSP("crossword1",
109     {one_across, one_down, two_down, three_across,
110     four_across},
111     [Constraint([one_across,one_down],
112     meet_at(0,0),"1a[0]==1d[0]"),
113     Constraint([one_across,two_down],
114     meet_at(2,0),"1a[2]==2d[0]"),
115     Constraint([three_across,two_down],
116     meet_at(2,2),"3a[2]==21d[2]"),
117     Constraint([three_across,one_down],
118     meet_at(0,2),"3a[0]==1d[2]"),
119     Constraint([four_across,two_down],
120     meet_at(0,4),"4a[0]==2d[4]")
121     ])

```

In an alternative representation of a crossword (the “dual” representation), the variables represent letters, and the constraints are that adjacent sequences of letters form words. This is shown in Figure 4.7.

```

cspExamples.py — (continued)
112 words = {'ant', 'big', 'bus', 'car', 'has', 'book', 'buys', 'hold',
113     'lane', 'year', 'ginger', 'search', 'symbol', 'syntax'}
114
115 def is_word(*letters, words=words):
116     """is true if the letters concatenated form a word in words"""
117     return "".join(letters) in words
118
119 letters = {"a", "b", "c", "d", "e", "f", "g", "h", "i", "j", "k", "l",
120     "m", "n", "o", "p", "q", "r", "s", "t", "u", "v", "w", "x", "y",

```

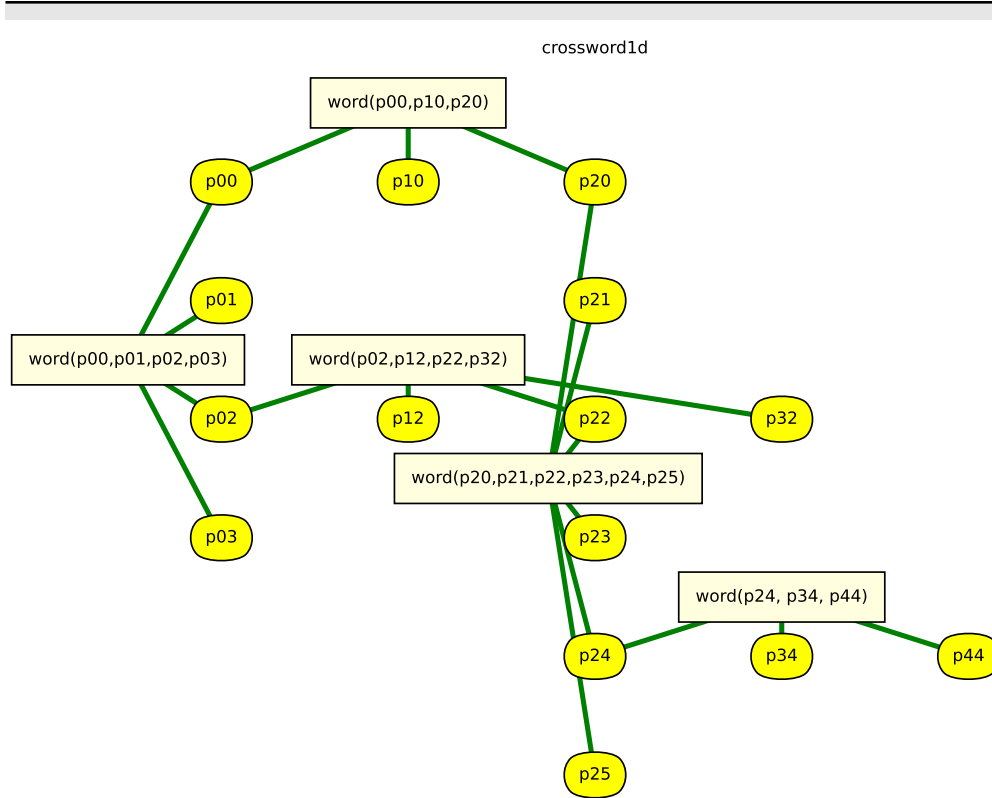

Figure 4.7: crossword1d.show()

```

121 "z"}
122
123 # pij is the variable representing the letter i from the left and j down
    (starting from 0)
124 p00 = Variable('p00', letters, position=(0.1,0.85))
125 p10 = Variable('p10', letters, position=(0.3,0.85))
126 p20 = Variable('p20', letters, position=(0.5,0.85))
127 p01 = Variable('p01', letters, position=(0.1,0.7))
128 p21 = Variable('p21', letters, position=(0.5,0.7))
129 p02 = Variable('p02', letters, position=(0.1,0.55))
130 p12 = Variable('p12', letters, position=(0.3,0.55))
131 p22 = Variable('p22', letters, position=(0.5,0.55))
132 p32 = Variable('p32', letters, position=(0.7,0.55))
133 p03 = Variable('p03', letters, position=(0.1,0.4))
134 p23 = Variable('p23', letters, position=(0.5,0.4))
135 p24 = Variable('p24', letters, position=(0.5,0.25))
136 p34 = Variable('p34', letters, position=(0.7,0.25))
137 p44 = Variable('p44', letters, position=(0.9,0.25))
138 p25 = Variable('p25', letters, position=(0.5,0.1))
139
140 crossword1d = CSP("crossword1d",

```

```

141     {p00, p10, p20, # first row
142       p01, p21, # second row
143       p02, p12, p22, p32, # third row
144       p03, p23, #fourth row
145       p24, p34, p44, # fifth row
146       p25 # sixth row
147     },
148     [Constraint([p00, p10, p20], is_word, "word(p00,p10,p20)",
149               position=(0.3,0.95)), #1-across
150     Constraint([p00, p01, p02, p03], is_word,
151               "word(p00,p01,p02,p03)",
152               position=(0,0.625)), # 1-down
153     Constraint([p02, p12, p22, p32], is_word,
154               "word(p02,p12,p22,p32)",
155               position=(0.3,0.625)), # 3-across
156     Constraint([p20, p21, p22, p23, p24, p25], is_word,
157               "word(p20,p21,p22,p23,p24,p25)",
158               position=(0.45,0.475)), # 2-down
159     Constraint([p24, p34, p44], is_word, "word(p24, p34,
160               p44)",
161               position=(0.7,0.325)) # 4-across
162     ])

```

Exercise 4.1 How many assignments of a value to each variable are there for each of the representations of the above crossword? Do you think an exhaustive enumeration will work for either one?

The queens problem is a puzzle on a chess board, where the idea is to place a queen on each column so the queens cannot take each other: there are no two queens on the same row, column or diagonal. The **n-queens problem** is a generalization where the size of the board is an $n \times n$, and n queens have to be placed.

Here is a representation of the n-queens problem, where the variables are the columns and the values are the rows in which the queen is placed. The original queens problem on a standard (8×8) chess board is `n_queens(8)`

```

cspExamples.py — (continued)
160 def queens(ri,rj):
161     """ri and rj are different rows, return the condition that the queens
162       cannot take each other"""
163     def no_take(ci,cj):
164         """is true if queen at (ri,ci) cannot take a queen at (rj,cj)"""
165         return ci != cj and abs(ri-ci) != abs(rj-cj)
166     return no_take
167 def n_queens(n):
168     """returns a CSP for n-queens"""
169     columns = list(range(n))
170     variables = [Variable(f"R{i}",columns) for i in range(n)]
171     # note positions will be random

```

```

172     return CSP("n-queens",
173               variables,
174               [Constraint([variables[i], variables[j]], queens(i,j),"" )
175                    for i in range(n) for j in range(n) if i != j])
176
177 # try the CSP n_queens(8) in one of the solvers.
178 # What is the smallest n for which there is a solution?

```

Exercise 4.2 How many constraints does this representation of the n-queens problem produce? Can it be done with fewer constraints? Either explain why it can't be done with fewer constraints, or give a solution using fewer constraints.

Unit tests

The following defines a **unit test** for csp solvers, by default using example csp1.

```

cspExamples.py — (continued)
180 def test_csp(CSP_solver, csp=csp1,
181             solutions=[{A: 1, B: 3, C: 4}, {A: 2, B: 3, C: 4}]):
182     """CSP_solver is a solver that takes a csp and returns a solution
183     csp is a constraint satisfaction problem
184     solutions is the list of all solutions to csp
185     This tests whether the solution returned by CSP_solver is a solution.
186     """
187     print("Testing csp with",CSP_solver.__doc__)
188     sol0 = CSP_solver(csp)
189     print("Solution found:",sol0)
190     assert sol0 in solutions, f"Solution not correct for {csp}"
191     print("Passed unit test")

```

Exercise 4.3 Modify *test* so that instead of taking in a list of solutions, it checks whether the returned solution actually is a solution.

Exercise 4.4 Propose a test that is appropriate for CSPs with no solutions. Assume that the test designer knows there are no solutions. Consider what a CSP solver should return if there are no solutions to the CSP.

Exercise 4.5 Write a unit test that checks whether all solutions (e.g., for the search algorithms that can return multiple solutions) are correct, and whether all solutions can be found.

4.2 A Simple Depth-first Solver

The first solver carries out a depth-first search through the space of partial assignments. This takes in a CSP problem and an optional variable ordering (a list of the variables in the CSP). It returns a generator of the solutions (see Section 1.5.3 on yield for enumerations).

```

cspDFS.py — Solving a CSP using depth-first search.
11 import cspExamples

```

```

12
13 def dfs_solver(constraints, context, var_order):
14     """generator for all solutions to csp.
15     context is an assignment of values to some of the variables.
16     var_order is a list of the variables in csp that are not in context.
17     """
18     to_eval = {c for c in constraints if c.can_evaluate(context)}
19     if all(c.holds(context) for c in to_eval):
20         if var_order == []:
21             yield context
22         else:
23             rem_cons = [c for c in constraints if c not in to_eval]
24             var = var_order[0]
25             for val in var.domain:
26                 yield from dfs_solver(rem_cons, context|{var:val},
27                                     var_order[1:])
28
29 def dfs_solve_all(csp, var_order=None):
30     """depth-first CSP solver to return a list of all solutions to csp.
31     """
32     if var_order == None: # use an arbitrary variable order
33         var_order = list(csp.variables)
34     return list(dfs_solver(csp.constraints, {}, var_order))
35
36 def dfs_solve1(csp, var_order=None):
37     """depth-first CSP solver"""
38     if var_order == None: # use an arbitrary variable order
39         var_order = list(csp.variables)
40     for sol in dfs_solver(csp.constraints, {}, var_order):
41         return sol #return first one
42
43 if __name__ == "__main__":
44     cspExamples.test_csp(dfs_solve1)
45
46 #Try:
47 # dfs_solve_all(cspExamples.csp1)
48 # dfs_solve_all(cspExamples.csp2)
49 # dfs_solve_all(cspExamples.crossword1)
50 # dfs_solve_all(cspExamples.crossword1d) # warning: may take a *very* long
51     time!

```

Exercise 4.6 Instead of testing all constraints at every node, change it so each constraint is only tested when all of its variables are assigned. Given an elimination ordering, it is possible to determine when each constraint needs to be tested. Implement this. Hint: create a parallel list of sets of constraints, where at each position i in the list, the constraints at position i can be evaluated when the variable at position i has been assigned.

Exercise 4.7 Estimate how long `dfs_solve_all(crossword1d)` will take on your computer. To do this, reduce the number of variables that need to be assigned, so that the simplified problem can be solved in a reasonable time (between 0.1

second and 10 seconds). This can be done by reducing the number of variables in `var_order`, as the program only splits on these. How much more time will it take if the number of variables is increased by 1? (Try it!) Then extrapolate to all of the variables. See Section 1.6.1 for how to time your code. Would making the code 100 times faster or using a computer 100 times faster help?

4.3 Converting CSPs to Search Problems

To run the demo, in folder "aipython", load "cspSearch.py", and copy and paste the example queries at the bottom of that file.

The next solver constructs a search space that can be solved using the search methods of the previous chapter. This takes in a CSP problem and an optional variable ordering, which is a list of the variables in the CSP. In this search space:

- A node is a *variable* : *value* dictionary which does not violate any constraints (so that dictionaries that violate any constraints are not added).
- An arc corresponds to an assignment of a value to the next variable. This assumes a static ordering; the next variable chosen to split does not depend on the context. If no variable ordering is given, this makes no attempt to choose a good ordering.

```

_____cspSearch.py — Representations of a Search Problem from a CSP. _____
11 from cspProblem import CSP, Constraint
12 from searchProblem import Arc, Search_problem
13
14 class Search_from_CSP(Search_problem):
15     """A search problem directly from the CSP.
16
17     A node is a variable:value dictionary"""
18     def __init__(self, csp, variable_order=None):
19         self.csp=csp
20         if variable_order:
21             assert set(variable_order) == set(csp.variables)
22             assert len(variable_order) == len(csp.variables)
23             self.variables = variable_order
24         else:
25             self.variables = list(csp.variables)
26
27     def is_goal(self, node):
28         """returns whether the current node is a goal for the search
29         """
30         return len(node)==len(self.csp.variables)
31
32     def start_node(self):
33         """returns the start node for the search

```

```

34 |     """
35 |     return {}

```

The `neighbors(node)` method uses the fact that the length of the node, which is the number of variables already assigned, is the index of the next variable to split on. Note that we do not need to check whether there are no more variables to split on, as the nodes are all consistent, by construction, and so when there are no more variables we have a solution, and so don't need the neighbors.

```

_____cspSearch.py — (continued)_____
37 | def neighbors(self, node):
38 |     """returns a list of the neighboring nodes of node.
39 |     """
40 |     var = self.variables[len(node)] # the next variable
41 |     res = []
42 |     for val in var.domain:
43 |         new_env = node|{var:val} #dictionary union
44 |         if self.csp.consistent(new_env):
45 |             res.append(Arc(node,new_env))
46 |     return res

```

The unit tests relies on a solver. The following procedure creates a solver using search that can be tested.

```

_____cspSearch.py — (continued)_____
48 | import cspExamples
49 | from searchGeneric import Searcher
50 |
51 | def solver_from_searcher(csp):
52 |     """depth-first search solver"""
53 |     path = Searcher(Search_from_CSP(csp)).search()
54 |     if path is not None:
55 |         return path.end()
56 |     else:
57 |         return None
58 |
59 | if __name__ == "__main__":
60 |     test_csp(solver_from_searcher)
61 |
62 | ## Test Solving CSPs with Search:
63 | searcher1 = Searcher(Search_from_CSP(cspExamples.csp1))
64 | #print(searcher1.search()) # get next solution
65 | searcher2 = Searcher(Search_from_CSP(cspExamples.csp2))
66 | #print(searcher2.search()) # get next solution
67 | searcher3 = Searcher(Search_from_CSP(cspExamples.crossword1))
68 | #print(searcher3.search()) # get next solution
69 | searcher4 = Searcher(Search_from_CSP(cspExamples.crossword1d))
70 | #print(searcher4.search()) # get next solution (warning: slow)

```

Exercise 4.8 What would happen if we constructed the new assignment by assigning `node[var] = val` (with side effects) instead of using dictionary union? Give

an example of where this could give a wrong answer. How could the algorithm be changed to work with side effects? (Hint: think about what information needs to be in a node).

Exercise 4.9 Change neighbors so that it returns an iterator of values rather than a list. (Hint: use *yield*.)

4.4 Consistency Algorithms

To run the demo, in folder "aipython", load "cspConsistency.py", and copy and paste the commented-out example queries at the bottom of that file.

A *Con_solver* is used to simplify a CSP using arc consistency.

```

_____cspConsistency.py — Arc Consistency and Domain splitting for solving a CSP_____
11 from display import Displayable
12
13 class Con_solver(Displayable):
14     """Solves a CSP with arc consistency and domain splitting
15     """
16     def __init__(self, csp):
17         """a CSP solver that uses arc consistency
18         * csp is the CSP to be solved
19         """
20         self.csp = csp

```

The following implementation of arc consistency maintains the set *to_do* of (variable, constraint) pairs that are to be checked. It takes in a domain dictionary and returns a new domain dictionary. It needs to be careful to avoid side effects; this is implemented here by copying the *domains* dictionary and the *to_do* set.

```

_____cspConsistency.py — (continued)_____
22 def make_arc_consistent(self, domains=None, to_do=None):
23     """Makes this CSP arc-consistent using generalized arc consistency
24     domains is a variable:domain dictionary
25     to_do is a set of (variable,constraint) pairs
26     returns the reduced domains (an arc-consistent variable:domain
27         dictionary)
28     """
29     if domains is None:
30         self.domains = {var:var.domain for var in self.csp.variables}
31     else:
32         self.domains = domains.copy() # use a copy of domains
33     if to_do is None:
34         to_do = {(var, const) for const in self.csp.constraints
35                 for var in const.scope}
36     else:

```

```

36         to_do = to_do.copy() # use a copy of to_do
37     self.display(5, "Performing AC with domains", self.domains)
38     while to_do:
39         self.arc_selected = (var, const) = self.select_arc(to_do)
40         self.display(5, "Processing arc (", var, ",", const, ")")
41         other_vars = [ov for ov in const.scope if ov != var]
42         new_domain = {val for val in self.domains[var]
43                     if self.any_holds(self.domains, const, {var:
44                                     val}, other_vars)}
45         if new_domain != self.domains[var]:
46             self.add_to_do = self.new_to_do(var, const) - to_do
47             self.display(3, f"Arc: ({var}, {const}) is inconsistent\n"
48                         f"Domain pruned, dom({var}) = {new_domain} due to
49                         {const}")
50             self.domains[var] = new_domain
51             self.display(4, " adding", self.add_to_do if self.add_to_do
52                         else "nothing", "to to_do.")
53             to_do |= self.add_to_do # set union
54             self.display(5, f"Arc: ({var},{const}) now consistent")
55         self.display(5, "AC done. Reduced domains", self.domains)
56     return self.domains
57
58 def new_to_do(self, var, const):
59     """returns new elements to be added to to_do after assigning
60     variable var in constraint const.
61     """
62     return {(nvar, nconst) for nconst in self.csp.var_to_const[var]
63           if nconst != const
64           for nvar in nconst.scope
65           if nvar != var}

```

The following selects an arc. Any element of *to_do* can be selected. The selected element needs to be removed from *to_do*. The default implementation just selects which ever element *pop* method for sets returns. The graphical user interface below allows the user to select an arc. Alternatively, a more sophisticated selection could be employed.

```

cspConsistency.py — (continued)
65 def select_arc(self, to_do):
66     """Selects the arc to be taken from to_do .
67     * to_do is a set of arcs, where an arc is a (variable,constraint)
68     pair
69     the element selected must be removed from to_do.
70     """
71     return to_do.pop()

```

The value of *new_domain* is the subset of the domain of *var* that is consistent with the assignment to the other variables. To make it easier to understand, the following treats unary (with no other variables in the constraint) and binary (with one other variables in the constraint) constraints as special cases. These cases are not strictly necessary; the last case covers the first two cases, but is

more difficult to understand without seeing the first two cases. Note that this case analysis is not in the code distribution, but can replace the assignment to `new_domain` above.

```

if len(other_vars)==0:          # unary constraint
    new_domain = {val for val in self.domains[var]
                  if const.holds({var:val})}
elif len(other_vars)==1:      # binary constraint
    other = other_vars[0]
    new_domain = {val for val in self.domains[var]
                  if any(const.holds({var: val, other: other_val})
                        for other_val in self.domains[other])}
else:                          # general case
    new_domain = {val for val in self.domains[var]
                  if self.any_holds(self.domains, const, {var: val}, other_vars)}

```

`any_holds` is a recursive function that tries to find an assignment of values to the other variables (`other_vars`) that satisfies constraint `const` given the assignment in `env`. The integer variable `ind` specifies which index to `other_vars` needs to be checked next. As soon as one assignment returns `True`, the algorithm returns `True`.

```

cspConsistency.py — (continued)
72 | def any_holds(self, domains, const, env, other_vars, ind=0):
73 |     """returns True if Constraint const holds for an assignment
74 |     that extends env with the variables in other_vars[ind:]
75 |     env is a dictionary
76 |     """
77 |     if ind == len(other_vars):
78 |         return const.holds(env)
79 |     else:
80 |         var = other_vars[ind]
81 |         for val in domains[var]:
82 |             if self.any_holds(domains, const, env|{var:val}, other_vars,
83 |                               ind + 1):
84 |                 return True
85 |         return False

```

4.4.1 Direct Implementation of Domain Splitting

The following is a direct implementation of domain splitting with arc consistency. It implements the generator interface of Python (see Section 1.5.3). When it has found a solution it yields the result; otherwise it recursively splits a domain (using `yield from`).

```

cspConsistency.py — (continued)
86 | def generate_sols(self, domains=None, to_do=None, context=dict()):
87 |     """return list of all solution to the current CSP

```

```

88     to_do is the list of arcs to check
89     context is a dictionary of splits made (used for display)
90     """
91     new_domains = self.make_arc_consistent(domains, to_do)
92     if any(len(new_domains[var]) == 0 for var in new_domains):
93         self.display(1, f"No solutions for context {context}")
94     elif all(len(new_domains[var]) == 1 for var in new_domains):
95         self.display(1, "solution:", str({var: select(
96             new_domains[var] for var in new_domains}))
97         yield {var: select(new_domains[var]) for var in new_domains}
98     else:
99         var = self.select_var(x for x in self.csp.variables if
100             len(new_domains[x]) > 1)
101         dom1, dom2 = partition_domain(new_domains[var])
102         self.display(5, "...splitting", var, "into", dom1, "and", dom2)
103         new_doms1 = new_domains | {var:dom1}
104         new_doms2 = new_domains | {var:dom2}
105         to_do = self.new_to_do(var, None)
106         self.display(4, " adding", to_do if to_do else "nothing", "to
107             to_do.")
108         yield from self.generate_sols(new_doms1, to_do,
109             context|{var:dom1})
110         yield from self.generate_sols(new_doms2, to_do,
111             context|{var:dom1})
112
113     def solve_all(self, domains=None, to_do=None):
114         return list(self.generate_sols())
115
116     def solve_one(self, domains=None, to_do=None):
117         return select(self.generate_sols())
118
119     def select_var(self, iter_vars):
120         """return the next variable to split"""
121         return select(iter_vars)
122
123     def partition_domain(dom):
124         """partitions domain dom into two.
125         """
126         split = len(dom) // 2
127         dom1 = set(list(dom)[:split])
128         dom2 = dom - dom1
129         return dom1, dom2

```

cspConsistency.py — (continued)

```

127 def select(iterable):
128     """select an element of iterable.
129     Returns None if there is no such element.
130
131     This implementation just picks the first element.
132     For many uses, which element is selected does not affect correctness,

```

```

133 |     but may affect efficiency.
134 |     """
135 |     for e in iterable:
136 |         return e # returns first element found

```

Exercise 4.10 Implement *solve_all* that returns the set of all solutions without using *yield*. Hint: it can be like *generate_sols* but returns a set of solutions; the recursive calls can be unioned; *|* is Python’s union.

Exercise 4.11 Implement *solve_one* that returns one solution if one exists, or *False* otherwise, without using *yield*. Hint: Python’s “or” has the behavior *A or B* will return the value of *A* unless it is *None* or *False*, in which case the value of *B* is returned.

Unit test:

```

_____cspConsistency.py — (continued)_____
138 | import cspExamples
139 | def ac_solver(csp):
140 |     "arc consistency (ac_solver)"
141 |     for sol in Con_solver(csp).generate_sols():
142 |         return sol
143 |
144 | if __name__ == "__main__":
145 |     cspExamples.test_csp(ac_solver)

```

4.4.2 Consistency GUI

The consistency GUI allows students to step through the algorithm, choosing which arc to process next, and which variable to split.

Figure 4.8 shows the state of the GUI after two arcs have been made arc consistent. The arcs on the *to_do* list arc colored blue. The green arcs are those have been made arc consistent. The user can click on a blue arc to process that arc. If the arc selected is not arc consistent, it is made red, the domain is reduced, and then the arc becomes green. If the arc was already arc consistent it turns green.

This is implemented by overriding *select_arc* and *select_var* to allow the user to pick the arcs and the variables, and overriding *display* to allow for the animation. Note that the first argument of *display* (the number) in the code above is interpreted with a special meaning by the GUI and should only be changed with care.

Clicking AutoAC automates arc selection until the network is arc consistent.

```

_____cspConsistencyGUI.py — GUI for consistency-based CSP solving_____
11 | from cspConsistency import Con_solver
12 | import matplotlib.pyplot as plt
13 |
14 | class ConsistencyGUI(Con_solver):
15 |     def __init__(self, csp, fontsize=10, speed=1, **kwargs):

```

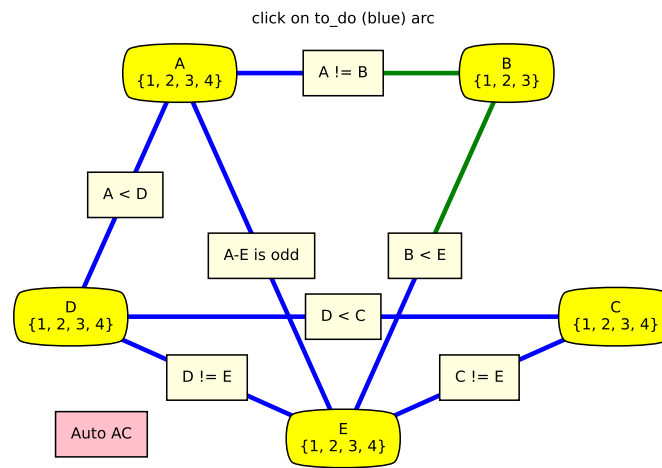

Figure 4.8: ConsistencyGUI(cspExamples.csp3).go()

```

16     """
17     csp is the csp to show
18     fontsize is the size of the text
19     speed is the number of animations per second (controls delay_time)
20     1 (slow) and 4 (fast) seem like good values
21     """
22     self.fontsize = fontsize
23     self.delay_time = 1/speed
24     self.quitting = False
25     Con_solver.__init__(self, csp, **kwargs)
26     csp.show(showAutoAC = True)
27     csp.fig.canvas.mpl_connect('close_event', self.window_closed)
28
29     def go(self):
30         try:
31             res = self.solve_all()
32             self.csp.draw_graph(domains=self.domains,
33                                 title="No more solutions. GUI finished. ",
34                                 fontsize=self.fontsize)
35             return res
36         except ExitToPython:
37             print("GUI closed")
38
39     def select_arc(self, to_do):
40         while True:
41             self.csp.draw_graph(domains=self.domains, to_do=to_do,
42                                 title="click on to_do (blue) arc",
43                                 fontsize=self.fontsize)
44             self.wait_for_user()

```

```

44         if self.csp.autoAC:
45             break
46         picked = self.csp.picked
47         self.csp.picked = None
48         if picked in to_do:
49             to_do.remove(picked)
50             print(f"{picked} picked")
51             return picked
52         else:
53             print(f"{picked} not in to_do. Pick one of {to_do}")
54     if self.csp.autoAC:
55         self.csp.draw_graph(domains=self.domains, to_do=to_do,
56                             title="Auto AC", fontsize=self.fontsize)
57         plt.pause(self.delay_time)
58         return to_do.pop()
59
60     def select_var(self, iter_vars):
61         vars = list(iter_vars)
62         while True:
63             self.csp.draw_graph(domains=self.domains,
64                                 title="Arc consistent. Click node to
65                                     split",
66                                 fontsize=self.fontsize)
67             self.csp.autoAC = False
68             self.wait_for_user()
69             picked = self.csp.picked
70             self.csp.picked = None
71             if picked in vars:
72                 #print("splitting",picked)
73                 return picked
74             else:
75                 print(picked,"not in",vars)
76
77     def display(self,n,*args,**nargs):
78         if n <= self.max_display_level: # default display
79             print(*args, **nargs)
80         if n==1: # solution found or no solutions"
81             self.csp.draw_graph(domains=self.domains, to_do=set(),
82                                 title=' '.join(args)+" : click any node or
83                                     arc to continue",
84                                 fontsize=self.fontsize)
85             self.csp.autoAC = False
86             self.wait_for_user()
87             self.csp.picked = None
88         elif n==2: # backtracking
89             plt.title("backtracking: click any node or arc to continue")
90             self.csp.autoAC = False
91             self.wait_for_user()
92             self.csp.picked = None
93         elif n==3: # inconsistent arc

```

```

92         line = self.csp.thelines[self.arc_selected]
93         line.set_color('red')
94         line.set_linewidth(10)
95         plt.pause(self.delay_time)
96         line.set_color('limegreen')
97         line.set_linewidth(self.csp.linewidth)
98     #elif n==4 and self.add_to_do: # adding to to_do
99     #    print("adding to to_do",self.add_to_do) ## highlight these arc
100
101     def wait_for_user(self):
102         while self.csp.picked == None and not self.csp.autoAC and not
103             self.quitting:
104             plt.pause(0.01) # controls reaction time of GUI
105         if self.quitting:
106             raise ExitToPython()
107
108     def window_closed(self, event):
109         self.quitting = True
110
111     class ExitToPython(Exception):
112         pass
113
114     import cspExamples
115     # Try:
116     # ConsistencyGUI(cspExamples.csp1).go()
117     # ConsistencyGUI(cspExamples.csp3).go()
118     # ConsistencyGUI(cspExamples.csp3, speed=4, fontsize=15).go()
119
120     if __name__ == "__main__":
121         print("Try e.g.: ConsistencyGUI(cspExamples.csp3).go()")

```

4.4.3 Domain Splitting as an interface to graph searching

An alternative implementation is to implement domain splitting in terms of the search abstraction of Chapter 3.

A node is a dictionary that maps the variables to their (pruned) domains..

```

_____cspConsistency.py — (continued)_____
147 from searchProblem import Arc, Search_problem
148
149 class Search_with_AC_from_CSP(Search_problem, Displayable):
150     """A search problem with arc consistency and domain splitting
151
152     A node is a CSP """
153     def __init__(self, csp):
154         self.cons = Con_solver(csp) #copy of the CSP
155         self.domains = self.cons.make_arc_consistent()
156
157     def is_goal(self, node):

```

```

158     """node is a goal if all domains have 1 element"""
159     return all(len(node[var])==1 for var in node)
160
161     def start_node(self):
162         return self.domains
163
164     def neighbors(self,node):
165         """returns the neighboring nodes of node.
166         """
167         neighs = []
168         var = select(x for x in node if len(node[x])>1)
169         if var:
170             dom1, dom2 = partition_domain(node[var])
171             self.display(2,"Splitting", var, "into", dom1, "and", dom2)
172             to_do = self.cons.new_to_do(var,None)
173             for dom in [dom1,dom2]:
174                 newdoms = node | {var:dom}
175                 cons_doms = self.cons.make_arc_consistent(newdoms,to_do)
176                 if all(len(cons_doms[v])>0 for v in cons_doms):
177                     # all domains are non-empty
178                     neighs.append(Arc(node,cons_doms))
179                 else:
180                     self.display(2,"...",var,"in",dom,"has no solution")
181         return neighs

```

Exercise 4.12 When splitting a domain, this code splits the domain into half, approximately in half (without any effort to make a sensible choice). Does it work better to split one element from a domain?

Unit test:

```

_____cspConsistency.py — (continued)_____
183 import cspExamples
184 from searchGeneric import Searcher
185
186 def ac_search_solver(csp):
187     """arc consistency (search interface)"""
188     sol = Searcher(Search_with_AC_from_CSP(csp)).search()
189     if sol:
190         return {v:select(d) for (v,d) in sol.end().items()}
191
192 if __name__ == "__main__":
193     cspExamples.test_csp(ac_search_solver)

```

Testing:

```

_____cspConsistency.py — (continued)_____
195 ## Test Solving CSPs with Arc consistency and domain splitting:
196 #Con_solver.max_display_level = 4 # display details of AC (0 turns off)
197 #Con_solver(cspExamples.csp1).solve_all()
198 #searcher1d = Searcher(Search_with_AC_from_CSP(cspExamples.csp1))

```

```

199 #print(searcher1d.search())
200 #Searcher.max_display_level = 2 # display search trace (0 turns off)
201 #searcher2c = Searcher(Search_with_AC_from_CSP(cspExamples.csp2))
202 #print(searcher2c.search())
203 #searcher3c = Searcher(Search_with_AC_from_CSP(cspExamples.crossword1))
204 #print(searcher3c.search())
205 #searcher4c = Searcher(Search_with_AC_from_CSP(cspExamples.crossword1d))
206 #print(searcher4c.search())

```

4.5 Solving CSPs using Stochastic Local Search

To run the demo, in folder "aipython", load "cspSLS.py", and copy and paste the commented-out example queries at the bottom of that file. This assumes Python 3. Some of the queries require matplotlib.

The following code implements the two-stage choice (select one of the variables that are involved in the most constraints that are violated, then a value), the any-conflict algorithm (select a variable that participates in a violated constraint) and a random choice of variable, as well as a probabilistic mix of the three.

Given a CSP, the stochastic local searcher (*SLSearcher*) creates the data structures:

- *variables_to_select* is the set of all of the variables with domain-size greater than one. For a variable not in this set, we cannot pick another value from that variable.
- *var_to_constraints* maps from a variable into the set of constraints it is involved in. Note that the inverse mapping from constraints into variables is part of the definition of a constraint.

```

cspSLS.py — Stochastic Local Search for Solving CSPs
11 from cspProblem import CSP, Constraint
12 from searchProblem import Arc, Search_problem
13 from display import Displayable
14 import random
15 import heapq
16
17 class SLSearcher(Displayable):
18     """A search problem directly from the CSP..
19
20     A node is a variable:value dictionary"""
21     def __init__(self, csp):
22         self.csp = csp
23         self.variables_to_select = {var for var in self.csp.variables
24                                   if len(var.domain) > 1}

```

```

25     # Create assignment and conflicts set
26     self.current_assignment = None # this will trigger a random restart
27     self.number_of_steps = 0 #number of steps after the initialization

```

restart creates a new total assignment, and constructs the set of conflicts (the constraints that are false in this assignment).

```

cspSLS.py -- (continued)
29     def restart(self):
30         """creates a new total assignment and the conflict set
31         """
32         self.current_assignment = {var:random_choice(var.domain) for
33                                   var in self.csp.variables}
34         self.display(2,"Initial assignment",self.current_assignment)
35         self.conflicts = set()
36         for con in self.csp.constraints:
37             if not con.holds(self.current_assignment):
38                 self.conflicts.add(con)
39         self.display(2,"Number of conflicts",len(self.conflicts))
40         self.variable_pq = None

```

The *search* method is the top-level searching algorithm. It can either be used to start the search or to continue searching. If there is no current assignment, it must create one. Note that, when counting steps, a restart is counted as one step, which is not appropriate for CSPs with many variables, as it is a relatively expensive operation for these cases.

This method selects one of two implementations. The argument *prob_best* is the probability of selecting a best variable (one involving the most conflicts). When the value of *prob_best* is positive, the algorithm needs to maintain a priority queue of variables and the number of conflicts (using *search_with_var_pq*). If the probability of selecting a best variable is zero, it does not need to maintain this priority queue (as implemented in *search_with_any_conflict*).

The argument *prob_anycon* is the probability that the any-conflict strategy is used (which selects a variable at random that is in a conflict), assuming that it is not picking a best variable. Note that for the probability parameters, any value less than zero acts like probability zero and any value greater than 1 acts like probability 1. This means that when *prob_anycon* = 1.0, a best variable is chosen with probability *prob_best*, otherwise a variable in any conflict is chosen. A variable is chosen at random with probability $1 - \text{prob_anycon} - \text{prob_best}$ as long as that is positive.

This returns the number of steps needed to find a solution, or *None* if no solution is found. If there is a solution, it is in *self.current_assignment*.

```

cspSLS.py -- (continued)
42     def search(self,max_steps, prob_best=0, prob_anycon=1.0):
43         """
44         returns the number of steps or None if there is no solution.
45         If there is a solution, it can be found in self.current_assignment
46

```

```

47 |         max_steps is the maximum number of steps it will try before giving
48 |         up
49 |         prob_best is the probability that a best variable (one in most
50 |         conflict) is selected
51 |         prob_anycon is the probability that a variable in any conflict is
52 |         selected
53 |         (otherwise a variable is chosen at random)
54 |         """
55 |         if self.current_assignment is None:
56 |             self.restart()
57 |             self.number_of_steps += 1
58 |             if not self.conflicts:
59 |                 self.display(1, "Solution found:", self.current_assignment,
60 |                             "after restart")
61 |                 return self.number_of_steps
62 |             if prob_best > 0: # we need to maintain a variable priority queue
63 |                 return self.search_with_var_pq(max_steps, prob_best,
64 |                                                prob_anycon)
65 |             else:
66 |                 return self.search_with_any_conflict(max_steps, prob_anycon)

```

Exercise 4.13 This does an initial random assignment but does not do any random restarts. Implement a searcher that takes in the maximum number of walk steps (corresponding to existing *max_steps*) and the maximum number of restarts, and returns the total number of steps for the first solution found. (As in *search*, the solution found can be extracted from the variable *self.current_assignment*).

4.5.1 Any-conflict

In the any-conflict heuristic a variable that participates in a violated constraint is picked at random. The implementation need to keeps track of which variables are in conflicts. This is can avoid the need for a priority queue that is needed when the probability of picking a best variable is greater than zero.

```

cspSLS.py — (continued)
63 | def search_with_any_conflict(self, max_steps, prob_anycon=1.0):
64 |     """Searches with the any_conflict heuristic.
65 |     This relies on just maintaining the set of conflicts;
66 |     it does not maintain a priority queue
67 |     """
68 |     self.variable_pq = None # we are not maintaining the priority queue.
69 |                             # This ensures it is regenerated if
70 |                             # we call search_with_var_pq.
71 |     for i in range(max_steps):
72 |         self.number_of_steps +=1
73 |         if random.random() < prob_anycon:
74 |             con = random.choice(self.conflicts) # pick random conflict
75 |             var = random.choice(con.scope) # pick variable in conflict
76 |         else:
77 |             var = random.choice(self.variables_to_select)

```

```

78         if len(var.domain) > 1:
79             val = random_choice([val for val in var.domain
80                                 if val is not
81                                     self.current_assignment[var]])
82         self.display(2, self.number_of_steps, ":
83             Assigning", var, "=", val)
84         self.current_assignment[var]=val
85         for varcon in self.csp.var_to_const[var]:
86             if varcon.holds(self.current_assignment):
87                 if varcon in self.conflicts:
88                     self.conflicts.remove(varcon)
89                 else:
90                     if varcon not in self.conflicts:
91                         self.conflicts.add(varcon)
92             self.display(2, " Number of conflicts", len(self.conflicts))
93         if not self.conflicts:
94             self.display(1, "Solution found:", self.current_assignment,
95                         "in", self.number_of_steps, "steps")
96             return self.number_of_steps
97         self.display(1, "No solution in", self.number_of_steps, "steps",
98                     len(self.conflicts), "conflicts remain")
99         return None

```

Exercise 4.14 This makes no attempt to find the best value for the variable selected. Modify the code to include an option selects a value for the selected variable that reduces the number of conflicts the most. Have a parameter that specifies the probability that the best value is chosen, and otherwise chooses a value at random.

4.5.2 Two-Stage Choice

This is the top-level searching algorithm that maintains a priority queue of variables ordered by the number of conflicts, so that the variable with the most conflicts is selected first. If there is no current priority queue of variables, one is created.

The main complexity here is to maintain the priority queue. When a variable *var* is assigned a value *val*, for each constraint that has become satisfied or unsatisfied, each variable involved in the constraint need to have its count updated. The change is recorded in the dictionary *var_differential*, which is used to update the priority queue (see Section 4.5.3).

```

cspSLS.py — (continued)
99     def search_with_var_pq(self, max_steps, prob_best=1.0, prob_anycon=1.0):
100         """search with a priority queue of variables.
101             This is used to select a variable with the most conflicts.
102             """
103         if not self.variable_pq:
104             self.create_pq()
105         pick_best_or_con = prob_best + prob_anycon

```

```

106     for i in range(max_steps):
107         self.number_of_steps +=1
108         randnum = random.random()
109         ## Pick a variable
110         if randnum < probabest: # pick best variable
111             var,oldval = self.variable_pq.top()
112         elif randnum < pick_best_or_con: # pick a variable in a conflict
113             con = random.choice(self.conflicts)
114             var = random.choice(con.scope)
115         else: #pick any variable that can be selected
116             var = random.choice(self.variables_to_select)
117         if len(var.domain) > 1: # var has other values
118             ## Pick a value
119             val = random.choice([val for val in var.domain if val is not
120                               self.current_assignment[var]])
121             self.display(2,"Assigning",var,val)
122             ## Update the priority queue
123             var_differential = {}
124             self.current_assignment[var]=val
125             for varcon in self.csp.var_to_const[var]:
126                 self.display(3,"Checking",varcon)
127                 if varcon.holds(self.current_assignment):
128                     if varcon in self.conflicts: # became consistent
129                         self.display(3,"Became consistent",varcon)
130                         self.conflicts.remove(varcon)
131                         for v in varcon.scope: # v is in one fewer
132                             conflicts
133                             var_differential[v] =
134                                 var_differential.get(v,0)-1
135                 else:
136                     if varcon not in self.conflicts: # was consis, not now
137                         self.display(3,"Became inconsistent",varcon)
138                         self.conflicts.add(varcon)
139                         for v in varcon.scope: # v is in one more
140                             conflicts
141                             var_differential[v] =
142                                 var_differential.get(v,0)+1
143             self.variable_pq.update_each_priority(var_differential)
144             self.display(2,"Number of conflicts",len(self.conflicts))
145         if not self.conflicts: # no conflicts, so solution found
146             self.display(1,"Solution found:",
147                         self.current_assignment,"in",
148                         self.number_of_steps,"steps")
149         return self.number_of_steps
150     self.display(1,"No solution in",self.number_of_steps,"steps",
151                 len(self.conflicts),"conflicts remain")
152     return None

```

`create_pq` creates an updatable priority queue of the variables, ordered by the number of conflicts they participate in. The priority queue only includes variables in conflicts and the value of a variable is the *negative* of the number of

conflicts the variable is in. This ensures that the priority queue, which picks the minimum value, picks a variable with the most conflicts.

```

cspSLS.py -- (continued)
149     def create_pq(self):
150         """Create the variable to number-of-conflicts priority queue.
151         This is needed to select the variable in the most conflicts.
152
153         The value of a variable in the priority queue is the negative of the
154         number of conflicts the variable appears in.
155         """
156         self.variable_pq = Updatable_priority_queue()
157         var_to_number_conflicts = {}
158         for con in self.conflicts:
159             for var in con.scope:
160                 var_to_number_conflicts[var] =
161                     var_to_number_conflicts.get(var, 0)+1
162         for var,num in var_to_number_conflicts.items():
163             if num>0:
164                 self.variable_pq.add(var, -num)

```

```

cspSLS.py -- (continued)
165     def random_choice(st):
166         """selects a random element from set st.
167         It would be more efficient to convert to a tuple or list only once
168         (left as exercise)."""
169         return random.choice(tuple(st))

```

Exercise 4.15 These implementations always select a value for the variable selected that is different from its current value (if that is possible). Change the code so that it does not have this restriction (so it can leave the value the same). Would you expect this code to be faster? Does it work worse (or better)?

4.5.3 Updatable Priority Queues

An **updatable priority queue** is a priority queue, where key-value pairs can be stored, and the pair with the smallest key can be found and removed quickly, and where the values can be updated. This implementation follows the idea of <http://docs.python.org/3.9/library/heapq.html>, where the updated elements are marked as removed. This means that the priority queue can be used unmodified. However, this might be expensive if changes are more common than popping (as might happen if the probability of choosing the best is close to zero).

In this implementation, the equal values are sorted randomly. This is achieved by having the elements of the heap being $[val, rand, elt]$ triples, where the second element is a random number. Note that Python requires this to be a list, not a tuple, as the tuple cannot be modified.

cspSLS.py — (continued)

```

171 class Updatable_priority_queue(object):
172     """A priority queue where the values can be updated.
173     Elements with the same value are ordered randomly.
174
175     This code is based on the ideas described in
176     http://docs.python.org/3.3/library/heapq.html
177     It could probably be done more efficiently by
178     shuffling the modified element in the heap.
179     """
180     def __init__(self):
181         self.pq = [] # priority queue of [val,rand,elt] triples
182         self.elt_map = {} # map from elt to [val,rand,elt] triple in pq
183         self.REMOVED = "*removed*" # a string that won't be a legal element
184         self.max_size=0
185
186     def add(self,elt,val):
187         """adds elt to the priority queue with priority=val.
188         """
189         assert val <= 0,val
190         assert elt not in self.elt_map, elt
191         new_triple = [val, random.random(),elt]
192         heapq.heappush(self.pq, new_triple)
193         self.elt_map[elt] = new_triple
194
195     def remove(self,elt):
196         """remove the element from the priority queue"""
197         if elt in self.elt_map:
198             self.elt_map[elt][2] = self.REMOVED
199             del self.elt_map[elt]
200
201     def update_each_priority(self,update_dict):
202         """update values in the priority queue by subtracting the values in
203         update_dict from the priority of those elements in priority queue.
204         """
205         for elt,incr in update_dict.items():
206             if incr != 0:
207                 newval = self.elt_map.get(elt,[0])[0] - incr
208                 assert newval <= 0, f"{elt}:{newval+incr}-{incr}"
209                 self.remove(elt)
210                 if newval != 0:
211                     self.add(elt,newval)
212
213     def pop(self):
214         """Removes and returns the (elt,value) pair with minimal value.
215         If the priority queue is empty, IndexError is raised.
216         """
217         self.max_size = max(self.max_size, len(self.pq)) # keep statistics
218         triple = heapq.heappop(self.pq)
219         while triple[2] == self.REMOVED:

```

```

220         triple = heapq.heappop(self.pq)
221         del self.elt_map[triple[2]]
222         return triple[2], triple[0] # elt, value
223
224     def top(self):
225         """Returns the (elt,value) pair with minimal value, without
226         removing it.
227         If the priority queue is empty, IndexError is raised.
228         """
229         self.max_size = max(self.max_size, len(self.pq)) # keep statistics
230         triple = self.pq[0]
231         while triple[2] == self.REMOVED:
232             heapq.heappop(self.pq)
233             triple = self.pq[0]
234         return triple[2], triple[0] # elt, value
235
236     def empty(self):
237         """returns True iff the priority queue is empty"""
238         return all(triple[2] == self.REMOVED for triple in self.pq)

```

4.5.4 Plotting Run-Time Distributions

Runtime_distribution uses matplotlib to plot run time distributions. Here the run time is a misnomer as we are only plotting the number of steps, not the time. Computing the run time is non-trivial as many of the runs have a very short run time. To compute the time accurately would require running the same code, with the same random seed, multiple times to get a good estimate of the run time. This is left as an exercise.

```

_____cspSLS.py — (continued)_____
239 import matplotlib.pyplot as plt
240 # plt.style.use('grayscale')
241
242 class Runtime_distribution(object):
243     def __init__(self, csp, xscale='log'):
244         """Sets up plotting for csp
245         xscale is either 'linear' or 'log'
246         """
247         self.csp = csp
248         plt.ion()
249         self.fig, self.ax = plt.subplots()
250         self.ax.set_xlabel("Number of Steps")
251         self.ax.set_ylabel("Cumulative Number of Runs")
252         self.ax.set_xscale(xscale) # Makes a 'log' or 'linear' scale
253
254     def plot_runs(self, num_runs=100, max_steps=1000, prob_best=1.0,
255                 prob_anycon=1.0):
256         """Plots num_runs of SLS for the given settings.
257         """

```

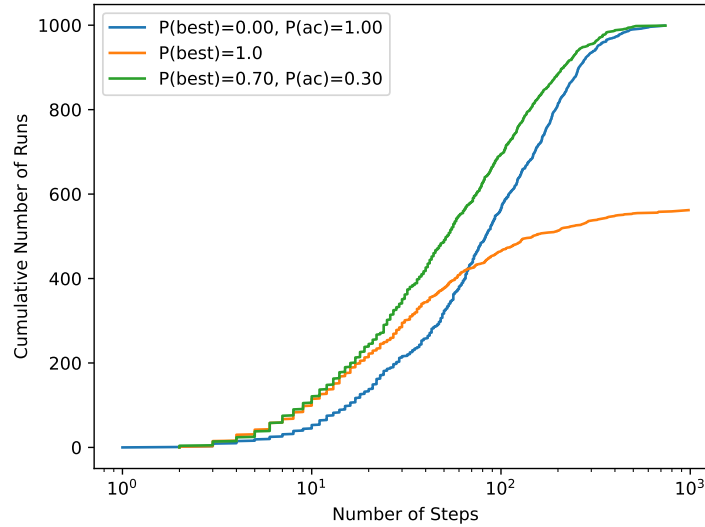

Figure 4.9: Run-time distributions for three algorithms on *csp2*.

```

257     stats = []
258     SLSearcher.max_display_level, temp_mdl = 0,
        SLSearcher.max_display_level # no display
259     for i in range(num_runs):
260         searcher = SLSearcher(self.csp)
261         num_steps = searcher.search(max_steps, prob_best, prob_anycon)
262         if num_steps:
263             stats.append(num_steps)
264     stats.sort()
265     if prob_best >= 1.0:
266         label = "P(best)=1.0"
267     else:
268         p_ac = min(prob_anycon, 1-prob_best)
269         label = "P(best)=%.2f, P(ac)=%.2f" % (prob_best, p_ac)
270     self.ax.plot(stats, range(len(stats)), label=label)
271     self.ax.legend(loc="upper left")
272     SLSearcher.max_display_level= temp_mdl #restore display

```

Figure 4.9 gives run-time distributions for 3 algorithms. It is also useful to compare the distributions of different runs of the same algorithms and settings.

4.5.5 Testing

cspSLS.py — (continued)

```
274 import cspExamples
```

```

275 def sls_solver(csp, prob_best=0.7):
276     """stochastic local searcher (prob_best=0.7)"""
277     se0 = SLSearcher(csp)
278     se0.search(1000, prob_best)
279     return se0.current_assignment
280 def any_conflict_solver(csp):
281     """stochastic local searcher (any-conflict)"""
282     return sls_solver(csp, 0)
283
284 if __name__ == "__main__":
285     cspExamples.test_csp(sls_solver)
286     cspExamples.test_csp(any_conflict_solver)
287
288 ## Test Solving CSPs with Search:
289 #se1 = SLSearcher(cspExamples.csp1); print(se1.search(100))
290 #se2 = SLSearcher(cspExamples.csp2); print(se2.search(1000, 1.0)) # greedy
291 #se2 = SLSearcher(cspExamples.csp2); print(se2.search(1000, 0)) #
    any_conflict
292 #se2 = SLSearcher(cspExamples.csp2); print(se2.search(1000, 0.7)) # 70%
    greedy; 30% any_conflict
293 #SLSearcher.max_display_level=2 #more detailed display
294 #se3 = SLSearcher(cspExamples.crossword1); print(se3.search(100), 0.7)
295 #p = Runtime_distribution(cspExamples.csp2)
296 #p.plot_runs(1000, 1000, 0) # any_conflict
297 #p.plot_runs(1000, 1000, 1.0) # greedy
298 #p.plot_runs(1000, 1000, 0.7) # 70% greedy; 30% any_conflict

```

Exercise 4.16 Modify this to plot the run time, instead of the number of steps. To measure run time use *timeit* (<https://docs.python.org/3.9/library/timeit.html>). Small run times are inaccurate, so *timeit* can run the same code multiple times. Stochastic local algorithms give different run times each time called. To make the timing meaningful, you need to make sure the random seed is the same for each repeated call (see *random.getstate* and *random.setstate* in <https://docs.python.org/3.9/library/random.html>). Because the run time for different seeds can vary a great deal, for each seed, you should start with 1 iteration and multiplying it by, say 10, until the time is greater than 0.2 seconds. Make sure you plot the average time for each run. Before you start, try to estimate the total run time, so you will be able to tell if there is a problem with the algorithm stopping.

4.6 Discrete Optimization

A *SoftConstraint* is a constraint, but where the condition is a real-valued cost function. The aim is to find the assignment with the lowest sum of costs. Because the definition of the constraint class did not force the condition to be Boolean, you can use the *Constraint* class for soft constraints too.

cspSoft.py — Representations of Soft Constraints

```

11 from cspProblem import Variable, Constraint, CSP
12 class SoftConstraint(Constraint):

```

```

13     """A Constraint consists of
14     * scope: a tuple of variables
15     * function: a real-valued costs function that can applied to a tuple of
16       values
17     * string: a string for printing the constraints. All of the strings
18       must be unique.
19     for the variables
20     """
21     def __init__(self, scope, function, string=None, position=None):
22         Constraint.__init__(self, scope, function, string, position)
23
24     def value(self,assignment):
25         return self.holds(assignment)

```

cspSoft.py — (continued)

```

26 A = Variable('A', {1,2}, position=(0.2,0.9))
27 B = Variable('B', {1,2,3}, position=(0.8,0.9))
28 C = Variable('C', {1,2}, position=(0.5,0.5))
29 D = Variable('D', {1,2}, position=(0.8,0.1))
30
31 def c1fun(a,b):
32     if a==1: return (5 if b==1 else 2)
33     else: return (0 if b==1 else 4 if b==2 else 3)
34 c1 = SoftConstraint([A,B],c1fun,"c1")
35 def c2fun(b,c):
36     if b==1: return (5 if c==1 else 2)
37     elif b==2: return (0 if c==1 else 4)
38     else: return (2 if c==1 else 0)
39 c2 = SoftConstraint([B,C],c2fun,"c2")
40 def c3fun(b,d):
41     if b==1: return (3 if d==1 else 0)
42     elif b==2: return 2
43     else: return (2 if d==1 else 4)
44 c3 = SoftConstraint([B,D],c3fun,"c3")
45
46 def penalty_if_same(pen):
47     """returns a function that gives a penalty of pen if the arguments are
48       the same"""
49     return lambda x,y: (pen if (x==y) else 0)
50
51 c4 = SoftConstraint([C,A],penalty_if_same(3),"c4")
52
53 scsp1 = CSP("scsp1", {A,B,C,D}, [c1,c2,c3,c4])
54
55 ### The second soft CSP has an extra variable, and 2 constraints
56 E = Variable('E', {1,2}, position=(0.1,0.1))
57
58 c5 = SoftConstraint([C,E],penalty_if_same(3),"c5")
59 c6 = SoftConstraint([D,E],penalty_if_same(2),"c6")
60 scsp2 = CSP("scsp1", {A,B,C,D,E}, [c1,c2,c3,c4,c5,c6])

```

4.6.1 Branch-and-bound Search

Here we specialize the branch-and-bound algorithm (Section 3.3 on page 65) to solve soft CSP problems.

```

cspSoft.py — (continued)
60 from display import Displayable
61 import math
62
63 class DF_branch_and_bound_opt(Displayable):
64     """returns a branch and bound searcher for a problem.
65     An optimal assignment with cost less than bound can be found by calling
66     search()
67     """
68     def __init__(self, csp, bound=math.inf):
69         """creates a searcher than can be used with search() to find an
70         optimal path.
71         bound gives the initial bound. By default this is infinite -
72         meaning there
73         is no initial pruning due to depth bound
74         """
75         self.csp = csp
76         self.best_asst = None
77         self.bound = bound
78
79     def optimize(self):
80         """returns an optimal solution to a problem with cost less than
81         bound.
82         returns None if there is no solution with cost less than bound."""
83         self.num_expanded=0
84         self.cbsearch({}, 0, self.csp.constraints)
85         self.display(1,"Number of paths expanded:",self.num_expanded)
86         return self.best_asst, self.bound
87
88     def cbsearch(self, asst, cost, constraints):
89         """finds the optimal solution that extends path and is less the
90         bound"""
91         self.display(2,"cbsearch:",asst,cost,constraints)
92         can_eval = [c for c in constraints if c.can_evaluate(asst)]
93         rem_cons = [c for c in constraints if c not in can_eval]
94         newcost = cost + sum(c.value(asst) for c in can_eval)
95         self.display(2,"Evaluating:",can_eval,"cost:",newcost)
96         if newcost < self.bound:
97             self.num_expanded += 1
98             if rem_cons==[]:
99                 self.best_asst = asst
100                self.bound = newcost
101                self.display(1,"New best assignment:",asst," cost:",newcost)
102            else:
103                var = next(var for var in self.csp.variables if var not in
104                    asst)

```

```
99         for val in var.domain:
100             self.cbsearch({var:val}|asst, newcost, rem_cons)
101
102     # bnb = DF_branch_and_bound_opt(scsp1)
103     # bnb.max_display_level=3 # show more detail
104     # bnb.optimize()
```

Exercise 4.17 What happens if some costs are negative? (Does it still work?) What if a value is added to all costs: does it change the optimum value, and does it affect efficiency? Make the algorithm work so that negative costs can be in the constraints. [Hint: make the smallest value be zero.]

Exercise 4.18 Change the stochastic-local search algorithms to work for soft constraints. Hint: Instead of the number of constraints violated, consider how much a change in a variable affects the objective function. Instead of returning a solution, return the best assignment found.

Propositions and Inference

5.1 Representing Knowledge Bases

A clause consists of a head (an atom) and a body. A body is represented as a list of atoms. Atoms are represented as strings, or any type that can be converted to strings.

```
logicProblem.py — Representations Logics
11 class Clause(object):
12     """A definite clause"""
13
14     def __init__(self, head, body=[]):
15         """clause with atom head and list of atoms body"""
16         self.head=head
17         self.body = body
18
19     def __repr__(self):
20         """returns the string representation of a clause.
21         """
22         if self.body:
23             return f"{self.head} <- {' & '.join(str(a) for a in
24                 self.body)}."
25         else:
26             return f"{self.head}."
```

An askable atom can be asked of the user. The user can respond in English or French or just with a “y”.

```
logicProblem.py — (continued)
27 class Askable(object):
28     """An askable atom"""
29
```

```

30     def __init__(self,atom):
31         """clause with atom head and lost of atoms body"""
32         self.atom=atom
33
34     def __str__(self):
35         """returns the string representation of a clause."""
36         return f"askable {self.atom}."
37
38     def yes(ans):
39         """returns true if the answer is yes in some form"""
40         return ans.lower() in ['yes', 'oui', 'y'] # bilingual

```

A knowledge base is a list of clauses and askables. To make top-down inference faster, this creates an `atom_to_clause` dictionary that maps each atom into the set of clauses with that atom in the head.

```

_____logicProblem.py — (continued) _____
42 from display import Displayable
43
44 class KB(Displayable):
45     """A knowledge base consists of a set of clauses.
46     This also creates a dictionary to give fast access to the clauses with
47     an atom in head.
48     """
49     def __init__(self, statements=[]):
50         self.statements = statements
51         self.clauses = [c for c in statements if isinstance(c, Clause)]
52         self.askables = [c.atom for c in statements if isinstance(c,
53             Askable)]
54         self.atom_to_clauses = {} # dictionary giving clauses with atom as
55             head
56         for c in self.clauses:
57             self.add_clause(c)
58
59     def add_clause(self, c):
60         if c.head in self.atom_to_clauses:
61             self.atom_to_clauses[c.head].append(c)
62         else:
63             self.atom_to_clauses[c.head] = [c]
64
65     def clauses_for_atom(self,a):
66         """returns list of clauses with atom a as the head"""
67         if a in self.atom_to_clauses:
68             return self.atom_to_clauses[a]
69         else:
70             return []
71
72     def __str__(self):
73         """returns a string representation of this knowledge base.
74         """
75         return '\n'.join([str(c) for c in self.statements])

```

Here is a trivial example (I think therefore I am) used in the unit tests:

```

----- logicProblem.py --- (continued) -----
74 triv_KB = KB([
75     Clause('i_am', ['i_think']),
76     Clause('i_think'),
77     Clause('i_smell', ['i_exist'])
78 ])

```

Here is a representation of the electrical domain of the textbook:

```

----- logicProblem.py --- (continued) -----
80 elect = KB([
81     Clause('light_l1'),
82     Clause('light_l2'),
83     Clause('ok_l1'),
84     Clause('ok_l2'),
85     Clause('ok_cb1'),
86     Clause('ok_cb2'),
87     Clause('live_outside'),
88     Clause('live_l1', ['live_w0']),
89     Clause('live_w0', ['up_s2', 'live_w1']),
90     Clause('live_w0', ['down_s2', 'live_w2']),
91     Clause('live_w1', ['up_s1', 'live_w3']),
92     Clause('live_w2', ['down_s1', 'live_w3']),
93     Clause('live_l2', ['live_w4']),
94     Clause('live_w4', ['up_s3', 'live_w3']),
95     Clause('live_p1', ['live_w3']),
96     Clause('live_w3', ['live_w5', 'ok_cb1']),
97     Clause('live_p2', ['live_w6']),
98     Clause('live_w6', ['live_w5', 'ok_cb2']),
99     Clause('live_w5', ['live_outside']),
100    Clause('lit_l1', ['light_l1', 'live_l1', 'ok_l1']),
101    Clause('lit_l2', ['light_l2', 'live_l2', 'ok_l2']),
102    Askable('up_s1'),
103    Askable('down_s1'),
104    Askable('up_s2'),
105    Askable('down_s2'),
106    Askable('up_s3'),
107    Askable('down_s2')
108 ])
109
110 # print(kb)

```

The following knowledge base is false in the intended interpretation. One of the clauses is wrong; can you see which one? We will show how to debug it.

```

----- logicProblem.py --- (continued) -----
111 elect_bug = KB([
112     Clause('light_l2'),
113     Clause('ok_l1'),
114     Clause('ok_l2'),

```

```

115     Clause('ok_cb1'),
116     Clause('ok_cb2'),
117     Clause('live_outside'),
118     Clause('live_p_2', ['live_w6']),
119     Clause('live_w6', ['live_w5', 'ok_cb2']),
120     Clause('light_l1'),
121     Clause('live_w5', ['live_outside']),
122     Clause('lit_l1', ['light_l1', 'live_l1', 'ok_l1']),
123     Clause('lit_l2', ['light_l2', 'live_l2', 'ok_l2']),
124     Clause('live_l1', ['live_w0']),
125     Clause('live_w0', ['up_s2', 'live_w1']),
126     Clause('live_w0', ['down_s2', 'live_w2']),
127     Clause('live_w1', ['up_s3', 'live_w3']),
128     Clause('live_w2', ['down_s1', 'live_w3' ]),
129     Clause('live_l2', ['live_w4']),
130     Clause('live_w4', ['up_s3', 'live_w3' ]),
131     Clause('live_p_1', ['live_w3']),
132     Clause('live_w3', ['live_w5', 'ok_cb1']),
133     Askable('up_s1'),
134     Askable('down_s1'),
135     Askable('up_s2'),
136     Clause('light_l2'),
137     Clause('ok_l1'),
138     Clause('light_l2'),
139     Clause('ok_l1'),
140     Clause('ok_l2'),
141     Clause('ok_cb1'),
142     Clause('ok_cb2'),
143     Clause('live_outside'),
144     Clause('live_p_2', ['live_w6']),
145     Clause('live_w6', ['live_w5', 'ok_cb2']),
146     Clause('ok_l2'),
147     Clause('ok_cb1'),
148     Clause('ok_cb2'),
149     Clause('live_outside'),
150     Clause('live_p_2', ['live_w6']),
151     Clause('live_w6', ['live_w5', 'ok_cb2']),
152     Askable('down_s2'),
153     Askable('up_s3'),
154     Askable('down_s2')
155 ]
156
157 # print(kb)

```

5.2 Bottom-up Proofs (with askables)

`fixed_point{kb}` computes the fixed point of the knowledge base `kb`.

logicBottomUp.py — Bottom-up Proof Procedure for Definite Clauses

```

11 from logicProblem import yes
12
13 def fixed_point(kb):
14     """Returns the fixed point of knowledge base kb.
15     """
16     fp = ask_askables(kb)
17     added = True
18     while added:
19         added = False # added is true when an atom was added to fp this
20             iteration
21         for c in kb.clauses:
22             if c.head not in fp and all(b in fp for b in c.body):
23                 fp.add(c.head)
24                 added = True
25                 kb.display(2,c.head,"added to fp due to clause",c)
26
27     return fp
28
29 def ask_askables(kb):
30     return {at for at in kb.askables if yes(input("Is "+at+" true? "))}

```

The following provides a trivial **unit test**, by default using the knowledge base `triv_KB`:

```

_____logicBottomUp.py — (continued) _____
30 from logicProblem import triv_KB
31 def test(kb=triv_KB, fixedpt = {'i_am','i_think'}):
32     fp = fixed_point(kb)
33     assert fp == fixedpt, f"kb gave result {fp}"
34     print("Passed unit test")
35 if __name__ == "__main__":
36     test()
37
38 from logicProblem import elect
39 # elect.max_display_level=3 # give detailed trace
40 # fixed_point(elect)

```

Exercise 5.1 It is not very user-friendly to ask all of the askables up-front. Implement `ask-the-user` so that questions are only asked if useful, and are not re-asked. For example, if there is a clause $h \leftarrow a \wedge b \wedge c \wedge d \wedge e$, where c and e are askable, c and e only need to be asked if a, b, d are all in fp and they have not been asked before. Askable e only needs to be asked if the user says “yes” to c . Askable c doesn’t need to be asked if the user previously replied “no” to e , unless it is needed for some other clause.

This form of `ask-the-user` can ask a different set of questions than the top-down interpreter that asks questions when encountered. Give an example where they ask different questions (neither set of questions asked is a subset of the other).

Exercise 5.2 This algorithm runs in time $O(n^2)$, where n is the number of clauses, for a bounded number of elements in the body; each iteration goes through each of the clauses, and in the worst case, it will do an iteration for each clause. It is possible to implement this in time $O(n)$ time by creating an index that maps an

atom to the set of clauses with that atom in the body. Implement this. What is its complexity as a function of n and b , the maximum number of atoms in the body of a clause?

Exercise 5.3 It is possible to be more efficient (in terms of the number of elements in a body) than the method in the previous question by noticing that each element of the body of clause only needs to be checked once. For example, the clause $a \leftarrow b \wedge c \wedge d$, needs only be considered when b is added to fp . Once b is added to fp , if c is already in fp , we know that a can be added as soon as d is added. Implement this. What is its complexity as a function of n and b , the maximum number of atoms in the body of a clause?

5.3 Top-down Proofs (with askables)

The following implements the top-down proof procedure for propositional definite clauses, as described in Section 5.3.2 and Figure 5.4 of Poole and Mackworth [2023]. It implements “choose” by looping over the alternatives (using Python’s `any`) and returning true if any choice leads to a proof.

`prove(kb, goal)` is used to prove `goal` from a knowledge base, `kb`, where a `goal` is a list of atoms. It returns `True` if $kb \vdash goal$. The `indent` is used when displaying the code (and doesn’t need to be called initially with a non-default value).

```

_____logicTopDown.py — Top-down Proof Procedure for Definite Clauses_____
11 from logicProblem import yes
12
13 def prove(kb, ans_body, indent=""):
14     """returns True if kb |- ans_body
15     ans_body is a list of atoms to be proved
16     """
17     kb.display(2,indent,'yes <-',' & '.join(ans_body))
18     if ans_body:
19         selected = ans_body[0] # select first atom from ans_body
20         if selected in kb.askables:
21             return (yes(input("Is "+selected+" true? "))
22                     and prove(kb,ans_body[1:],indent+" "))
23         else:
24             return any(prove(kb,cl.body+ans_body[1:],indent+" ")
25                        for cl in kb.clauses_for_atom(selected))
26     else:
27         return True # empty body is true

```

The following provides a simple **unit test** that is hard wired for `triv_KB`:

```

_____logicTopDown.py — (continued)_____
29 from logicProblem import triv_KB
30 def test():
31     a1 = prove(triv_KB,['i_am'])
32     assert a1, f"triv_KB proving i_am gave {a1}"
33     a2 = prove(triv_KB,['i_smell'])

```

```

34     assert not a2, f"triv_KB proving i_smell gave {a2}"
35     print("Passed unit tests")
36 if __name__ == "__main__":
37     test()
38 # try
39 from logicProblem import elect
40 # elect.max_display_level=3 # give detailed trace
41 # prove(elect,['live_w6'])
42 # prove(elect,['lit_l1'])

```

Exercise 5.4 This code can re-ask a question multiple times. Implement this code so that it only asks a question once and remembers the answer. Also implement a function to forget the answers, which is useful if someone given an incorrect response.

Exercise 5.5 What search method is this using? Implement the search interface so that it can use A^* or other searching methods. Define an admissible heuristic that is not always 0.

5.4 Debugging and Explanation

Here we modify the top-down procedure to build a proof tree than can be traversed for explanation and debugging.

`prove_atom(kb,atom)` returns a proof for *atom* from a knowledge base *kb*, where a proof is a pair of the atom and the proofs for the elements of the body of the clause used to prove the atom. `prove_body(kb,body)` returns a list of proofs for list *body* from a knowledge base, *kb*. The *indent* is used when displaying the code (and doesn't need to have a non-default value).

```

_____logicExplain.py — Explaining Proof Procedure for Definite Clauses _____
11 from logicProblem import yes # for asking the user
12
13 def prove_atom(kb, atom, indent=""):
14     """returns a pair (atom,proofs) where proofs is the list of proofs
15     of the elements of a body of a clause used to prove atom.
16     """
17     kb.display(2,indent,'proving',atom)
18     if atom in kb.askables:
19         if yes(input("Is "+atom+" true? ")):
20             return (atom,"answered")
21         else:
22             return "fail"
23     else:
24         for cl in kb.clauses_for_atom(atom):
25             kb.display(2,indent,"trying",atom,'<-',' & '.join(cl.body))
26             pr_body = prove_body(kb, cl.body, indent)
27             if pr_body != "fail":
28                 return (atom, pr_body)
29     return "fail"

```

```

30
31 def prove_body(kb, ans_body, indent=""):
32     """returns proof tree if kb |- ans_body or "fail" if there is no proof
33     ans_body is a list of atoms in a body to be proved
34     """
35     proofs = []
36     for atom in ans_body:
37         proof_at = prove_atom(kb, atom, indent+" ")
38         if proof_at == "fail":
39             return "fail" # fail if any proof fails
40         else:
41             proofs.append(proof_at)
42     return proofs

```

The following provides a simple **unit test** that is hard wired for `triv_KB`:

```

_____logicExplain.py — (continued)_____
44 from logicProblem import triv_KB
45 def test():
46     a1 = prove_atom(triv_KB, 'i_am')
47     assert a1, f"triv_KB proving i_am gave {a1}"
48     a2 = prove_atom(triv_KB, 'i_smell')
49     assert a2!="fail", "triv_KB proving i_smell gave {a2}"
50     print("Passed unit tests")
51
52 if __name__ == "__main__":
53     test()
54
55 # try
56 from logicProblem import elect, elect_bug
57 # elect.max_display_level=3 # give detailed trace
58 # prove_atom(elect, 'live_w6')
59 # prove_atom(elect, 'lit_l1')

```

The `interact(kb)` provides an interactive interface to explore proofs for knowledge base `kb`. The user can ask to prove atoms and can ask how an atom was proved.

To ask how, there must be a current atom for which there is a proof. This starts as the atom asked. When the user asks “how *n*” the current atom becomes the *n*-th element of the body of the clause used to prove the (previous) current atom. The command “up” makes the current atom the atom in the head of the rule containing the (previous) current atom. Thus “how *n*” moves down the proof tree and “up” moves up the proof tree, allowing the user to explore the full proof.

```

_____logicExplain.py — (continued)_____
61 helptext = """Commands are:
62 ask atom    ask is there is a proof for atom (atom should not be in quotes)
63 how        show the clause that was used to prove atom
64 how n      show the clause used to prove the nth element of the body

```

```

65 up          go back up proof tree to explore other parts of the proof tree
66 kb          print the knowledge base
67 quit        quit this interaction (and go back to Python)
68 help        print this text
69 """
70
71 def interact(kb):
72     going = True
73     ups = [] # stack for going up
74     proof="fail" # there is no proof to start
75     while going:
76         inp = input("logicExplain: ")
77         inps = inp.split(" ")
78         try:
79             command = inps[0]
80             if command == "quit":
81                 going = False
82             elif command == "ask":
83                 proof = prove_atom(kb, inps[1])
84                 if proof == "fail":
85                     print("fail")
86                 else:
87                     print("yes")
88             elif command == "how":
89                 if proof=="fail":
90                     print("there is no proof")
91                 elif len(inps)==1:
92                     print_rule(proof)
93                 else:
94                     try:
95                         ups.append(proof)
96                         proof = proof[1][int(inps[1])] #nth argument of rule
97                         print_rule(proof)
98                     except:
99                         print('In "how n", n must be a number between 0
100                            and',len(proof[1])-1,"inclusive.")
101             elif command == "up":
102                 if ups:
103                     proof = ups.pop()
104                 else:
105                     print("No rule to go up to.")
106                     print_rule(proof)
107             elif command == "kb":
108                 print(kb)
109             elif command == "help":
110                 print(helpertext)
111             else:
112                 print("unknown command:", inp)
113                 print("use help for help")
114         except:

```

```

114         print("unknown command:", inp)
115         print("use help for help")
116
117     def print_rule(proof):
118         (head,body) = proof
119         if body == "answered":
120             print(head,"was answered yes")
121         elif body == []:
122             print(head,"is a fact")
123         else:
124             print(head,"<-")
125             for i,a in enumerate(body):
126                 print(i,":",a[0])
127
128     # try
129     # interact(elect)
130     # Which clause is wrong in elect_bug? Try:
131     # interact(elect_bug)
132     # logicExplain: ask lit_l1

```

The following shows an interaction for the knowledge base elect:

```

>>> interact(elect)
logicExplain: ask lit_l1
Is up_s2 true? no
Is down_s2 true? yes
Is down_s1 true? yes
yes
logicExplain: how
lit_l1 <-
0 : light_l1
1 : live_l1
2 : ok_l1
logicExplain: how 1
live_l1 <-
0 : live_w0
logicExplain: how 0
live_w0 <-
0 : down_s2
1 : live_w2
logicExplain: how 0
down_s2 was answered yes
logicExplain: up
live_w0 <-
0 : down_s2
1 : live_w2
logicExplain: how 1
live_w2 <-

```

```

0 : down_s1
1 : live_w3
logicExplain: quit
>>>

```

Exercise 5.6 The above code only ever explores one proof – the first proof found. Change the code to enumerate the proof trees (by returning a list of all proof trees, or, preferably, using `yield`). Add the command "retry" to the user interface to try another proof.

5.5 Assumables

Atom a can be made assumable by including $Assumable(a)$ in the knowledge base. A knowledge base that can include assumables is declared with KBA .

```

_____logicAssumables.py — Definite clauses with assumables_____
11 from logicProblem import Clause, Askable, KB, yes
12
13 class Assumable(object):
14     """An askable atom"""
15
16     def __init__(self,atom):
17         """clause with atom head and lost of atoms body"""
18         self.atom = atom
19
20     def __str__(self):
21         """returns the string representation of a clause.
22         """
23         return "assumable " + self.atom + "."
24
25 class KBA(KB):
26     """A knowledge base that can include assumables"""
27     def __init__(self,statements):
28         self.assumables = [c.atom for c in statements if isinstance(c,
29             Assumable)]
29         KB.__init__(self,statements)

```

The top-down Horn clause interpreter, `prove_all_ass` returns a list of the sets of assumables that imply `ans_body`. This list will contain all of the minimal sets of assumables, but can also find non-minimal sets, and repeated sets, if they can be generated with separate proofs. The set *assumed* is the set of assumables already assumed.

```

_____logicAssumables.py — (continued)_____
31 def prove_all_ass(self, ans_body, assumed=set()):
32     """returns a list of sets of assumables that extends assumed
33     to imply ans_body from self.
34     ans_body is a list of atoms (it is the body of the answer clause).
35     assumed is a set of assumables already assumed

```

```

36     """
37     if ans_body:
38         selected = ans_body[0] # select first atom from ans_body
39         if selected in self.askables:
40             if yes(input("Is "+selected+" true? ")):
41                 return self.prove_all_ass(ans_body[1:], assumed)
42             else:
43                 return [] # no answers
44         elif selected in self.assumables:
45             return self.prove_all_ass(ans_body[1:], assumed|{selected})
46         else:
47             return [ass
48                     for cl in self.clauses_for_atom(selected)
49                     for ass in
50                         self.prove_all_ass(cl.body+ans_body[1:], assumed)
51                         ] # union of answers for each clause with
52                         head=selected
53     else:
54         # empty body
55         return [assumed] # one answer
56
57 def conflicts(self):
58     """returns a list of minimal conflicts"""
59     return minsets(self.prove_all_ass(['false']))

```

Given a list of sets, *minsets* returns a list of the minimal sets in the list. For example, *minsets*([$\{2,3,4\}$, $\{2,3\}$, $\{6,2,3\}$, $\{2,3\}$, $\{2,4,5\}$]) returns [$\{2,3\}$, $\{2,4,5\}$].

```

logicAssumables.py — (continued)
58 def minsets(ls):
59     """ls is a list of sets
60     returns a list of minimal sets in ls
61     """
62     ans = [] # elements known to be minimal
63     for c in ls:
64         if not any(c1<c for c1 in ls) and not any(c1 <= c for c1 in ans):
65             ans.append(c)
66     return ans
67
68 # minsets([{2, 3, 4}, {2, 3}, {6, 2, 3}, {2, 3}, {2, 4, 5}])

```

Warning: *minsets* works for a list of sets or for a set of (frozen) sets, but it does not work for a generator of sets (because variable *ls* is referenced in the loop). For example, try to predict and then test:

```
minsets(e for e in [{2, 3, 4}, {2, 3}, {6, 2, 3}, {2, 3}, {2, 4, 5}])
```

The diagnoses can be constructed from the (minimal) conflicts as follows. This also works if there are non-minimal conflicts, but is not as efficient.

```

logicAssumables.py — (continued)
69 def diagnoses(cons):
70     """cons is a list of (minimal) conflicts.

```

```

71     returns a list of diagnoses."""
72     if cons == []:
73         return [set()]
74     else:
75         return minsets([(e)|d]          # | is set union
76                        for e in cons[0]
77                        for d in diagnoses(cons[1:]))

```

Test cases:

```

                                logicAssumables.py — (continued)
80 electa = KBA([
81     Clause('light_l1'),
82     Clause('light_l2'),
83     Assumable('ok_l1'),
84     Assumable('ok_l2'),
85     Assumable('ok_s1'),
86     Assumable('ok_s2'),
87     Assumable('ok_s3'),
88     Assumable('ok_cb1'),
89     Assumable('ok_cb2'),
90     Assumable('live_outside'),
91     Clause('live_l1', ['live_w0']),
92     Clause('live_w0', ['up_s2', 'ok_s2', 'live_w1']),
93     Clause('live_w0', ['down_s2', 'ok_s2', 'live_w2']),
94     Clause('live_w1', ['up_s1', 'ok_s1', 'live_w3']),
95     Clause('live_w2', ['down_s1', 'ok_s1', 'live_w3' ]),
96     Clause('live_l2', ['live_w4']),
97     Clause('live_w4', ['up_s3', 'ok_s3', 'live_w3' ]),
98     Clause('live_p1', ['live_w3']),
99     Clause('live_w3', ['live_w5', 'ok_cb1']),
100    Clause('live_p2', ['live_w6']),
101    Clause('live_w6', ['live_w5', 'ok_cb2']),
102    Clause('live_w5', ['live_outside']),
103    Clause('lit_l1', ['light_l1', 'live_l1', 'ok_l1']),
104    Clause('lit_l2', ['light_l2', 'live_l2', 'ok_l2']),
105    Askable('up_s1'),
106    Askable('down_s1'),
107    Askable('up_s2'),
108    Askable('down_s2'),
109    Askable('up_s3'),
110    Askable('down_s2'),
111    Askable('dark_l1'),
112    Askable('dark_l2'),
113    Clause('false', ['dark_l1', 'lit_l1']),
114    Clause('false', ['dark_l2', 'lit_l2'])
115 ])
116 # electa.prove_all_ass(['false'])
117 # cs=electa.conflicts()
118 # print(cs)
119 # diagnoses(cs)      # diagnoses from conflicts

```

Exercise 5.7 To implement a version of conflicts that never generates non-minimal conflicts, modify `prove_all_ass` to implement iterative deepening on the number of assumables used in a proof, and prune any set of assumables that is a superset of a conflict.

Exercise 5.8 Implement `explanations(self, body)`, where `body` is a list of atoms, that returns a list of the minimal explanations of the body. This does not require modification of `prove_all_ass`.

Exercise 5.9 Implement `explanations`, as in the previous question, so that it never generates non-minimal explanations. Hint: modify `prove_all_ass` to implement iterative deepening on the number of assumptions, generating conflicts and explanations together, and pruning as early as possible.

5.6 Negation-as-failure

The negation of an atom `a` is written as `Not(a)` in a body.

```

_____logicNegation.py — Propositional negation-as-failure _____
11 from logicProblem import KB, Clause, Askable, yes
12
13 class Not(object):
14     def __init__(self, atom):
15         self.theatom = atom
16
17     def atom(self):
18         return self.theatom
19
20     def __repr__(self):
21         return f"Not({self.theatom})"
```

Prove with negation-as-failure (`prove_naf`) is like `prove`, but with the extra case to cover `Not`:

```

_____logicNegation.py — (continued) _____
23 def prove_naf(kb, ans_body, indent=""):
24     """ prove with negation-as-failure and askables
25     returns True if kb |- ans_body
26     ans_body is a list of atoms to be proved
27     """
28     kb.display(2, indent, 'yes <-', ' & '.join(str(e) for e in ans_body))
29     if ans_body:
30         selected = ans_body[0] # select first atom from ans_body
31         if isinstance(selected, Not):
32             kb.display(2, indent, f"proving {selected.atom()}")
33             if prove_naf(kb, [selected.atom()], indent):
34                 kb.display(2, indent, f"{selected.atom()} succeeded so
35                 Not({selected.atom()}) fails")
36                 return False
37         else:
```

```

37         kb.display(2,indent,f"{selected.atom()} fails so
           Not({selected.atom()}) succeeds")
38         return prove_naf(kb, ans_body[1:],indent+" ")
39     if selected in kb.askables:
40         return (yes(input("Is "+selected+" true? "))
41                 and prove_naf(kb,ans_body[1:],indent+" "))
42     else:
43         return any(prove_naf(kb,c1.body+ans_body[1:],indent+" ")
44                   for c1 in kb.clauses_for_atom(selected))
45     else:
46         return True # empty body is true

```

Test cases:

```

----- logicNegation.py --- (continued) -----
48 triv_KB_naf = KB([
49     Clause('i_am', ['i_think']),
50     Clause('i_think'),
51     Clause('i_smell', ['i_am', Not('dead')]),
52     Clause('i_bad', ['i_am', Not('i_think')])
53 ])
54
55 triv_KB_naf.max_display_level = 4
56 def test():
57     a1 = prove_naf(triv_KB_naf,['i_smell'])
58     assert a1, f"triv_KB_naf failed to prove i_smell; gave {a1}"
59     a2 = prove_naf(triv_KB_naf,['i_bad'])
60     assert not a2, f"triv_KB_naf wrongly proved i_bad; gave {a2}"
61     print("Passed unit tests")
62 if __name__ == "__main__":
63     test()

```

Default reasoning about beaches at resorts (Example 5.28 of Poole and Mackworth [2023]):

```

----- logicNegation.py --- (continued) -----
65 beach_KB = KB([
66     Clause('away_from_beach', [Not('on_beach')]),
67     Clause('beach_access', ['on_beach', Not('ab_beach_access')]),
68     Clause('swim_at_beach', ['beach_access', Not('ab_swim_at_beach')]),
69     Clause('ab_swim_at_beach', ['enclosed_bay', 'big_city',
           Not('ab_no_swimming_near_city')]),
70     Clause('ab_no_swimming_near_city', ['in_BC', Not('ab_BC_beaches')])
71 ])
72
73 # prove_naf(beach_KB, ['away_from_beach'])
74 # prove_naf(beach_KB, ['beach_access'])
75 # beach_KB.add_clause(Clause('on_beach', []))
76 # prove_naf(beach_KB, ['away_from_beach'])
77 # prove_naf(beach_KB, ['swim_at_beach'])
78 # beach_KB.add_clause(Clause('enclosed_bay', []))
79 # prove_naf(beach_KB, ['swim_at_beach'])

```

```
80 | # beach_KB.add_clause(Clause('big_city', []))
81 | # prove_naf(beach_KB, ['swim_at_beach'])
82 | # beach_KB.add_clause(Clause('in_BC', []))
83 | # prove_naf(beach_KB, ['swim_at_beach'])
```

Deterministic Planning

6.1 Representing Actions and Planning Problems

The STRIPS representation of an action consists of:

- the name of the action
- preconditions: a dictionary of *feature:value* pairs that specifies that the feature must have this value for the action to be possible
- effects: a dictionary of *feature:value* pairs that are made true by this action. In particular, a feature in the dictionary has the corresponding value (and not its previous value) after the action, and a feature not in the dictionary keeps its old value.
- a cost for the action

```
stripsProblem.py — STRIPS Representations of Actions
11 class Strips(object):
12     def __init__(self, name, preconds, effects, cost=1):
13         """
14         defines the STRIPS representation for an action:
15         * name is the name of the action
16         * preconds, the preconditions, is feature:value dictionary that
           must hold
17         for the action to be carried out
18         * effects is a feature:value map that this action makes
19         true. The action changes the value of any feature specified
20         here, and leaves other features unchanged.
```

```

21     * cost is the cost of the action
22     """
23     self.name = name
24     self.preconds = preconds
25     self.effects = effects
26     self.cost = cost
27
28     def __repr__(self):
29         return self.name

```

A STRIPS domain consists of:

- A dictionary `feature_domain_dict` that maps each feature into a set of possible values for the feature. This is needed for the CSP planner.
- A set of actions, each represented using the `Strips` class.

stripsProblem.py — (continued)

```

31 class STRIPS_domain(object):
32     def __init__(self, feature_domain_dict, actions):
33         """Problem domain
34         feature_domain_dict is a feature:domain dictionary,
35         mapping each feature to its domain
36         actions
37         """
38         self.feature_domain_dict = feature_domain_dict
39         self.actions = actions

```

A planning problem consists of a planning domain, an initial state, and a goal. The goal does not need to fully specify the final state.

stripsProblem.py — (continued)

```

41 class Planning_problem(object):
42     def __init__(self, prob_domain, initial_state, goal):
43         """
44         a planning problem consists of
45         * a planning domain
46         * the initial state
47         * a goal
48         """
49         self.prob_domain = prob_domain
50         self.initial_state = initial_state
51         self.goal = goal

```

6.1.1 Robot Delivery Domain

The following specifies the robot delivery domain of Section 6.1, shown in Figure 6.1.

**Features to describe states***RLoc* – Rob's location*RHC* – Rob has coffee*SWC* – Sam wants coffee*MW* – Mail is waiting*RHM* – Rob has mail**Actions***mc* – move clockwise*mcc* – move counterclockwise*puc* – pickup coffee*dc* – deliver coffee*pum* – pickup mail*dm* – deliver mail

Figure 6.1: Robot Delivery Domain

stripsProblem.py — (continued)

```

53 boolean = {False, True}
54 delivery_domain = STRIPS_domain(
55     {'RLoc':{'cs', 'off', 'lab', 'mr'}, 'RHC':boolean, 'SWC':boolean,
56      'MW':boolean, 'RHM':boolean},          #feature:values dictionary
57     { Strips('mc_cs', {'RLoc':'cs'}, {'RLoc':'off'}),
58       Strips('mc_off', {'RLoc':'off'}, {'RLoc':'lab'}),
59       Strips('mc_lab', {'RLoc':'lab'}, {'RLoc':'mr'}),
60       Strips('mc_mr', {'RLoc':'mr'}, {'RLoc':'cs'}),
61       Strips('mcc_cs', {'RLoc':'cs'}, {'RLoc':'mr'}),
62       Strips('mcc_off', {'RLoc':'off'}, {'RLoc':'cs'}),
63       Strips('mcc_lab', {'RLoc':'lab'}, {'RLoc':'off'}),
64       Strips('mcc_mr', {'RLoc':'mr'}, {'RLoc':'lab'}),
65       Strips('puc', {'RLoc':'cs', 'RHC':False}, {'RHC':True}),
66       Strips('dc', {'RLoc':'off', 'RHC':True}, {'RHC':False, 'SWC':False}),
67       Strips('pum', {'RLoc':'mr', 'MW':True}, {'RHM':True, 'MW':False}),
68       Strips('dm', {'RLoc':'off', 'RHM':True}, {'RHM':False})
69     } )

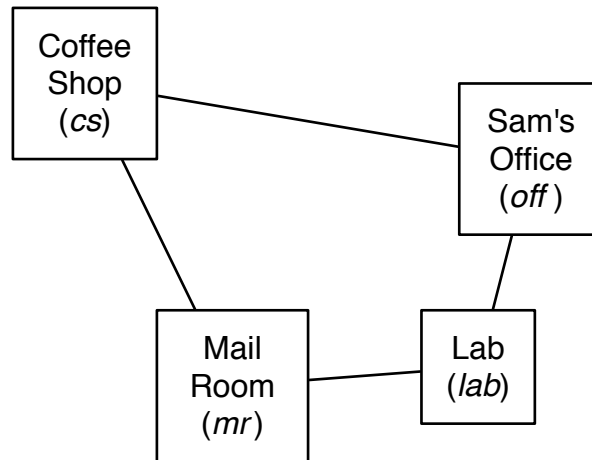
```

stripsProblem.py — (continued)

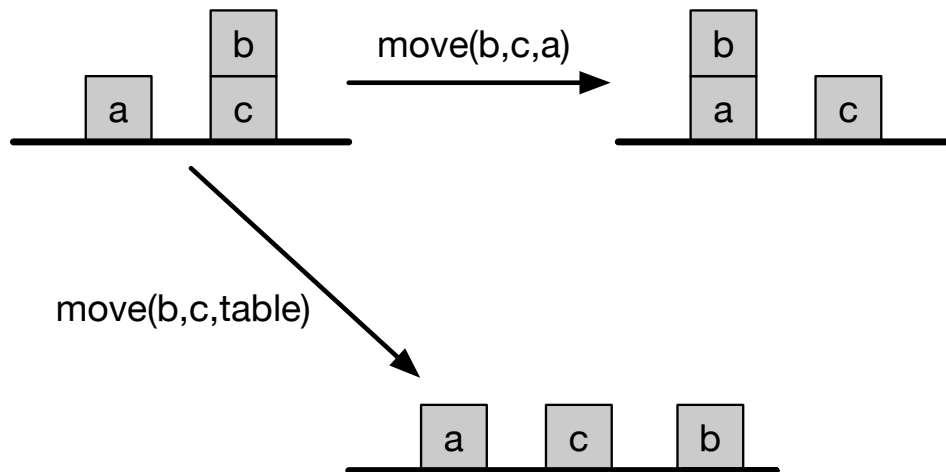

Figure 6.2: Blocks world with two actions

```

71 | problem0 = Planning_problem(delivery_domain,
72 |                             {'RLoc': 'lab', 'MW': True, 'SWC': True, 'RHC': False,
73 |                             'RHM': False},
74 |                             {'RLoc': 'off'})
75 | problem1 = Planning_problem(delivery_domain,
76 |                             {'RLoc': 'lab', 'MW': True, 'SWC': True, 'RHC': False,
77 |                             'RHM': False},
78 |                             {'SWC': False})
79 | problem2 = Planning_problem(delivery_domain,
80 |                             {'RLoc': 'lab', 'MW': True, 'SWC': True, 'RHC': False,
81 |                             'RHM': False},
82 |                             {'SWC': False, 'MW': False, 'RHM': False})

```

6.1.2 Blocks World

The blocks world consist of blocks and a table. Each block can be on the table or on another block. A block can only have one other block on top of it. Figure 6.2 shows 3 states with some of the actions between them.

A state is defined by the two features:

- *on* where $on(x) = y$ when block x is on block or table y
- *clear* where $clear(x) = True$ when block x has nothing on it.

There is one parameterized action

- $move(x, y, z)$ move block x from y to z , where y and z could be a block or the table.

To handle parameterized actions (which depend on the blocks involved), the actions and the features are all strings, created for all the combinations of the blocks. Note that we treat moving to a block separately from moving to the table, because the blocks needs to be clear, but the table always has room for another block.

```

stripsProblem.py — (continued)
84  """ blocks world
85  def move(x,y,z):
86      """string for the 'move' action"""
87      return 'move_'+x+'_from_'+y+'_to_'+z
88  def on(x):
89      """string for the 'on' feature"""
90      return x+'_is_on'
91  def clear(x):
92      """string for the 'clear' feature"""
93      return 'clear_'+x
94  def create_blocks_world(blocks = {'a','b','c','d'}):
95      blocks_and_table = blocks | {'table'}
96      stmap = {Strips(move(x,y,z),{on(x):y, clear(x):True, clear(z):True},
97                  {on(x):z, clear(y):True, clear(z):False})
98              for x in blocks
99              for y in blocks_and_table
100             for z in blocks
101             if x!=y and y!=z and z!=x}
102      stmap.update({Strips(move(x,y,'table'), {on(x):y, clear(x):True},
103                  {on(x):'table', clear(y):True})
104                  for x in blocks
105                  for y in blocks
106                  if x!=y})
107      feature_domain_dict = {on(x):blocks_and_table-{x} for x in blocks}
108      feature_domain_dict.update({clear(x):boolean for x in blocks_and_table})
109      return STRIPS_domain(feature_domain_dict, stmap)

```

The problem *blocks1* is a classic example, with 3 blocks, and the goal consists of two conditions. See Figure 6.3. This example is challenging because you can't achieve one of the goals (using the minimum number of actions) and then the other; whichever one you achieve first has to be undone to achieve the second.

```

stripsProblem.py — (continued)
111 blocks1dom = create_blocks_world({'a','b','c'})
112 blocks1 = Planning_problem(blocks1dom,
113     {on('a'):'table', clear('a'):True,
114     on('b'):'c', clear('b'):True,
115     on('c'):'table', clear('c'):False}, # initial state
116     {on('a'):'b', on('c'):'a'}) #goal

```

The problem *blocks2* is one to invert a tower of size 4.

```

stripsProblem.py — (continued)
118 blocks2dom = create_blocks_world({'a','b','c','d'})

```

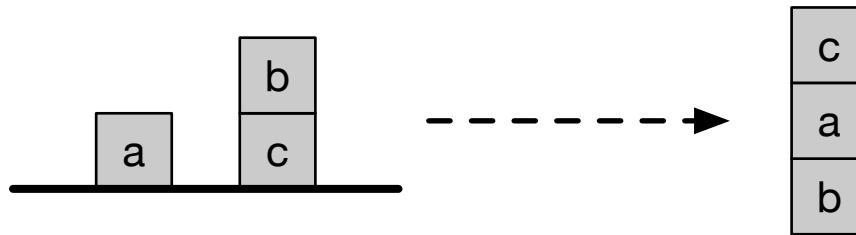

Figure 6.3: Blocks problem blocks1

```

119 tower4 = {clear('a'):True, on('a'):'b',
120           clear('b'):False, on('b'):'c',
121           clear('c'):False, on('c'):'d',
122           clear('d'):False, on('d'):'table'}
123 blocks2 = Planning_problem(blocks2dom,
124                             tower4, # initial state
125                             {'on('d'):'c',on('c'):'b',on('b'):'a'}) #goal

```

The problem *blocks3* is to move the bottom block to the top of a tower of size 4.

stripsProblem.py — (continued)

```

127 blocks3 = Planning_problem(blocks2dom,
128                             tower4, # initial state
129                             {'on('d'):'a', on('a'):'b', on('b'):'c'}) #goal

```

Exercise 6.1 Represent the problem of given a tower of 4 blocks (*a* on *b* on *c* on *d* on table), the goal is to have a tower with the previous top block on the bottom (*b* on *c* on *d* on *a*). Do not include the table in your goal (the goal does not care whether *a* is on the table). [Before you run the program, estimate how many steps it will take to solve this.] How many steps does an optimal planner take?

Exercise 6.2 Represent the domain so that $on(x, y)$ is a Boolean feature that is True when *x* is on *y*. Does the representation of the state need to include negative *on* facts? Why or why not? (Note that this may depend on the planner; write your answer with respect to particular planners.)

Exercise 6.3 It is possible to write the representation of the problem without using *clear*, where $clear(x)$ means nothing is on *x*. Change the definition of the blocks world so that it does not use *clear* but uses *on* being false instead. Does this work better for any of the planners?

6.2 Forward Planning

To run the demo, in folder "aipython", load "stripsForwardPlanner.py", and copy and paste the commented-out example queries at the bottom of that file.

In a forward planner, a node is a state. A state consists of an assignment, a feature:value dictionary, where all features have a value. Multiple-path pruning requires a hash function, and equality between states.

```

stripsForwardPlanner.py — Forward Planner with STRIPS actions
11 from searchProblem import Arc, Search_problem
12 from stripsProblem import Strips, STRIPS_domain
13
14 class State(object):
15     def __init__(self, assignment):
16         self.assignment = assignment
17         self.hash_value = None
18     def __hash__(self):
19         if self.hash_value is None:
20             self.hash_value = hash(frozenset(self.assignment.items()))
21         return self.hash_value
22     def __eq__(self, st):
23         return self.assignment == st.assignment
24     def __str__(self):
25         return str(self.assignment)

```

To define a search problem (page 41), you need to define the goal condition, the start nodes, the neighbors, and (optionally) a heuristic function. Here zero is the default heuristic function.

```

stripsForwardPlanner.py — (continued)
27 def zero(*args,**nargs):
28     """always returns 0"""
29     return 0
30
31 class Forward_STRIPS(Search_problem):
32     """A search problem from a planning problem where:
33     * a node is a state
34     * the dynamics are specified by the STRIPS representation of actions
35     """
36     def __init__(self, planning_problem, heur=zero):
37         """creates a forward search space from a planning problem.
38         heur(state,goal) is a heuristic function,
39         an underestimate of the cost from state to goal, where
40         both state and goals are feature:value dictionaries.
41         """
42         self.prob_domain = planning_problem.prob_domain
43         self.initial_state = State(planning_problem.initial_state)
44         self.goal = planning_problem.goal
45         self.heur = heur
46
47     def is_goal(self, state):
48         """is True if node is a goal.
49
50         Every goal feature has the same value in the state and the goal."""
51         return all(state.assignment[prop]==self.goal[prop]

```

```

52         for prop in self.goal)
53
54     def start_node(self):
55         """returns start node"""
56         return self.initial_state
57
58     def neighbors(self, state):
59         """returns neighbors of state in this problem"""
60         return [ Arc(state, self.effect(act, state.assignment), act.cost,
61                    act)
62                 for act in self.prob_domain.actions
63                 if self.possible(act, state.assignment)]
64
65     def possible(self, act, state_asst):
66         """True if act is possible in state.
67         act is possible if all of its preconditions have the same value in
68         the state"""
69         return all(state_asst[pre] == act.preconds[pre]
70                  for pre in act.preconds)
71
72     def effect(self, act, state_asst):
73         """returns the state that is the effect of doing act given
74         state_asst
75         Python 3.9: return state_asst | act.effects"""
76         new_state_asst = state_asst.copy()
77         new_state_asst.update(act.effects)
78         return State(new_state_asst)
79
80     def heuristic(self, state):
81         """in the forward planner a node is a state.
82         the heuristic is an (under)estimate of the cost
83         of going from the state to the top-level goal.
84         """
85         return self.heur(state.assignment, self.goal)

```

Here are some test cases to try.

```

stripsForwardPlanner.py — (continued)
84 from searchBranchAndBound import DF_branch_and_bound
85 from searchMPP import SearcherMPP
86 import stripsProblem
87
88 # SearcherMPP(Forward_STRIPS(stripsProblem.problem1)).search() #A* with MPP
89 # DF_branch_and_bound(Forward_STRIPS(stripsProblem.problem1), 10).search()
90 #B&B
91 # To find more than one plan:
92 # s1 = SearcherMPP(Forward_STRIPS(stripsProblem.problem1)) #A*
93 # s1.search() #find another plan

```

6.2.1 Defining Heuristics for a Planner

Each planning domain requires its own heuristics. If you change the actions, you will need to reconsider the heuristic function, as there might then be a lower-cost path, which might make the heuristic non-admissible.

Here is an example of defining heuristics for the coffee delivery planning domain.

First define the distance between two locations, which is used for the heuristics.

```

stripsHeuristic.py — Planner with Heuristic Function
11 def dist(loc1, loc2):
12     """returns the distance from location loc1 to loc2
13     """
14     if loc1==loc2:
15         return 0
16     if {loc1,loc2} in [{'cs','lab'},{'mr','off'}]:
17         return 2
18     else:
19         return 1

```

Note that the current state is a complete description; there is a value for every feature. However the goal need not be complete; it does not need to define a value for every feature. Before checking the value for a feature in the goal, a heuristic needs to define whether the feature is defined in the goal.

```

stripsHeuristic.py — (continued)
21 def h1(state,goal):
22     """ the distance to the goal location, if there is one"""
23     if 'RLoc' in goal:
24         return dist(state['RLoc'], goal['RLoc'])
25     else:
26         return 0
27
28 def h2(state,goal):
29     """ the distance to the coffee shop plus getting coffee and delivering
30     it
31     if the robot needs to get coffee
32     """
33     if ('SWC' in goal and goal['SWC']==False
34         and state['SWC']==True
35         and state['RHC']==False):
36         return dist(state['RLoc'],'cs')+3
37     else:
38         return 0

```

The maximum of the values of a set of admissible heuristics is also an admissible heuristic. The function `maxh` takes a number of heuristic functions as arguments, and returns a new heuristic function that takes the maximum of the values of the heuristics. For example, `h1` and `h2` are heuristic functions and so `maxh(h1, h2)` is also. `maxh` can take an arbitrary number of arguments.

```

stripsHeuristic.py — (continued)
39 def maxh(*heuristics):
40     """Returns a new heuristic function that is the maximum of the
        functions in heuristics.
41     heuristics is the list of arguments which must be heuristic functions.
42     """
43     # return lambda state,goal: max(h(state,goal) for h in heuristics)
44     def newh(state,goal):
45         return max(h(state,goal) for h in heuristics)
46     return newh

```

The following runs the example with and without the heuristic.

```

stripsHeuristic.py — (continued)
48 ##### Forward Planner #####
49 from searchMPP import SearcherMPP
50 from stripsForwardPlanner import Forward_STRIPS
51 import stripsProblem
52
53 def test_forward_heuristic(thisproblem=stripsProblem.problem1):
54     print("\n***** FORWARD NO HEURISTIC")
55     print(SearcherMPP(Forward_STRIPS(thisproblem)).search())
56
57     print("\n***** FORWARD WITH HEURISTIC h1")
58     print(SearcherMPP(Forward_STRIPS(thisproblem,h1)).search())
59
60     print("\n***** FORWARD WITH HEURISTIC h2")
61     print(SearcherMPP(Forward_STRIPS(thisproblem,h2)).search())
62
63     print("\n***** FORWARD WITH HEURISTICS h1 and h2")
64     print(SearcherMPP(Forward_STRIPS(thisproblem,maxh(h1,h2))).search())
65
66 if __name__ == "__main__":
67     test_forward_heuristic()

```

Exercise 6.4 For more than one start-state/goal combination, test the forward planner with a heuristic function of just h1, with just h2 and with both. Explain why each one prunes or doesn't prune the search space.

Exercise 6.5 Create a better heuristic than $\max(h_1, h_2)$. Try it for a number of different problems. In particular, try and include the following costs:

- i) h3 is like h2 but also takes into account the case when Rloc is in goal.
- ii) h4 uses the distance to the mail room plus getting mail and delivering it if the robot needs to get need to deliver mail.
- iii) h5 is for getting mail when goal is for the robot to have mail, and then getting to the goal destination (if there is one).

Exercise 6.6 Create an admissible heuristic for the blocks world.

6.3 Regression Planning

To run the demo, in folder "aipython", load "stripsRegressionPlanner.py", and copy and paste the commented-out example queries at the bottom of that file.

In a regression planner a node is a subgoal that need to be achieved. A Subgoal consists of an assignment, a *feature:value* dictionary, which assigns some – but typically not all – of the state features. It is hashable so that multiple path pruning can work. The hash is only computed when necessary (and only once).

```

stripsRegressionPlanner.py — Regression Planner with STRIPS actions
11 from searchProblem import Arc, Search_problem
12
13 class Subgoal(object):
14     def __init__(self, assignment):
15         self.assignment = assignment
16         self.hash_value = None
17     def __hash__(self):
18         if self.hash_value is None:
19             self.hash_value = hash(frozenset(self.assignment.items()))
20         return self.hash_value
21     def __eq__(self, st):
22         return self.assignment == st.assignment
23     def __str__(self):
24         return str(self.assignment)

```

A regression search has subgoals as nodes. The initial node is the top-level goal of the planner. The goal for the search (when the search can stop) is a subgoal that holds in the initial state.

```

stripsRegressionPlanner.py — (continued)
26 from stripsForwardPlanner import zero
27
28 class Regression_STRIPS(Search_problem):
29     """A search problem where:
30     * a node is a goal to be achieved, represented by a set of propositions.
31     * the dynamics are specified by the STRIPS representation of actions
32     """
33
34     def __init__(self, planning_problem, heur=zero):
35         """creates a regression search space from a planning problem.
36         heur(state,goal) is a heuristic function;
37         an underestimate of the cost from state to goal, where
38         both state and goals are feature:value dictionaries
39         """
40         self.prob_domain = planning_problem.prob_domain
41         self.top_goal = Subgoal(planning_problem.goal)
42         self.initial_state = planning_problem.initial_state

```

```

43     self.heur = heur
44
45     def is_goal(self, subgoal):
46         """if subgoal is true in the initial state, a path has been found"""
47         goal_asst = subgoal.assignment
48         return all(self.initial_state[g]==goal_asst[g]
49                 for g in goal_asst)
50
51     def start_node(self):
52         """the start node is the top-level goal"""
53         return self.top_goal
54
55     def neighbors(self,subgoal):
56         """returns a list of the arcs for the neighbors of subgoal in this
57         problem"""
58         goal_asst = subgoal.assignment
59         return [ Arc(subgoal, self.weakest_precond(act,goal_asst),
60                 act.cost, act)
61                 for act in self.prob_domain.actions
62                 if self.possible(act,goal_asst)]
63
64     def possible(self,act,goal_asst):
65         """True if act is possible to achieve goal_asst.
66
67         the action achieves an element of the effects and
68         the action doesn't delete something that needs to be achieved and
69         the preconditions are consistent with other subgoals that need to
70         be achieved
71         """
72         return ( any(goal_asst[prop] == act.effects[prop]
73                 for prop in act.effects if prop in goal_asst)
74                 and all(goal_asst[prop] == act.effects[prop]
75                 for prop in act.effects if prop in goal_asst)
76                 and all(goal_asst[prop]== act.preconds[prop]
77                 for prop in act.preconds if prop not in act.effects
78                 and prop in goal_asst)
79                 )
80
81     def weakest_precond(self,act,goal_asst):
82         """returns the subgoal that must be true so goal_asst holds after
83         act
84         should be: act.preconds | (goal_asst - act.effects)
85         """
86         new_asst = act.preconds.copy()
87         for g in goal_asst:
88             if g not in act.effects:
89                 new_asst[g] = goal_asst[g]
90         return Subgoal(new_asst)
91
92     def heuristic(self,subgoal):

```

```

88     """in the regression planner a node is a subgoal.
89     the heuristic is an (under)estimate of the cost of going from the
90     initial state to subgoal.
91     """
92     return self.heur(self.initial_state, subgoal.assignment)

```

```

stripsRegressionPlanner.py — (continued)
93 from searchBranchAndBound import DF_branch_and_bound
94 from searchMPP import SearcherMPP
95 import stripsProblem
96
97 # SearcherMPP(Regression_STRIPS(stripsProblem.problem1)).search() #A* with
98 # MPP
99 #
100 # DF_branch_and_bound(Regression_STRIPS(stripsProblem.problem1),10).search()
101 #B&B

```

Exercise 6.7 Multiple path pruning could be used to prune more than the current node. In particular, if the current node contains more conditions than a previously visited node, it can be pruned. For example, if $\{a:\text{True}, b:\text{False}\}$ has been visited, then any node that is a superset, e.g., $\{a:\text{True}, b:\text{False}, d:\text{True}\}$, need not be expanded. If the simpler subgoal does not lead to a solution, the more complicated one will not either. Implement this more severe pruning. (Hint: This may require modifications to the searcher.)

Exercise 6.8 It is possible that, as knowledge of the domain, that some assignment of values to features can never be achieved. For example, the robot cannot be holding mail when there is mail waiting (assuming it isn't holding mail initially). An assignment of values to (some of the) features is incompatible if no possible (reachable) state can include that assignment. For example, $\{\text{'MW':True}, \text{'RHM':True}\}$ is an incompatible assignment. This information may be useful information for a planner; there is no point in trying to achieve these together. Define a subclass of STRIPS_domain that can accept a list of incompatible assignments. Modify the regression planner code to use such a list of incompatible assignments. Give an example where the search space is smaller.

Exercise 6.9 After completing the previous exercise, design incompatible assignments for the blocks world. (This can result in dramatic search improvements.)

6.3.1 Defining Heuristics for a Regression Planner

The regression planner can use the same heuristic function as the forward planner. However, just because a heuristic is useful for a forward planner does not mean it is useful for a regression planner, and vice versa. you should experiment with whether the same heuristic works well for both a regression planner and a forward planner.

The following runs the same example as the forward planner with and without the heuristic defined for the forward planner:

```

stripsHeuristic.py — (continued)
69 ##### Regression Planner
70 from stripsRegressionPlanner import Regression_STRIPS
71
72 def test_regression_heuristic(thisproblem=stripsProblem.problem1):
73     print("\n***** REGRESSION NO HEURISTIC")
74     print(SearcherMPP(Regression_STRIPS(thisproblem)).search())
75
76     print("\n***** REGRESSION WITH HEURISTICS h1 and h2")
77     print(SearcherMPP(Regression_STRIPS(thisproblem,maxh(h1,h2))).search())
78
79 if __name__ == "__main__":
80     test_regression_heuristic()

```

Exercise 6.10 Try the regression planner with a heuristic function of just h_1 and with just h_2 (defined in Section 6.2.1). Explain how each one prunes or doesn't prune the search space.

Exercise 6.11 Create a heuristic that is better for regression planning than `heuristic_fun` defined in Section 6.2.1.

6.4 Planning as a CSP

To run the demo, in folder "aipython", load "stripsCSPPlanner.py", and copy and paste the commented-out example queries at the bottom of that file. This assumes Python 3.

The CSP planner assumes there is a single action at each step. This creates a CSP that can use any of the CSP algorithms to solve (e.g., stochastic local search or arc consistency with domain splitting).

It uses the same action representation as before; it does not consider factored actions (action features), or implement state constraints.

```

stripsCSPPlanner.py — CSP planner where actions are represented using STRIPS
11 from cspProblem import Variable, CSP, Constraint
12
13 class CSP_from_STRIPS(CSP):
14     """A CSP where:
15     * CSP variables are constructed for each feature and time, and each
16       action and time
17     * the dynamics are specified by the STRIPS representation of actions
18     """
19     def __init__(self, planning_problem, number_stages=2):
20         prob_domain = planning_problem.prob_domain
21         initial_state = planning_problem.initial_state
22         goal = planning_problem.goal
23         # self.action_vars[t] is the action variable for time t

```

```

24     self.action_vars = [Variable(f"Action{t}", prob_domain.actions)
25                          for t in range(number_stages)]
26     # feat_time_var[f][t] is the variable for feature f at time t
27     feat_time_var = {feat: [Variable(f"{feat}_{t}", dom)
28                             for t in range(number_stages+1)]
29                       for (feat, dom) in
30                          prob_domain.feature_domain_dict.items()}
31
32     # initial state constraints:
33     constraints = [Constraint([feat_time_var[feat][0]], is_(val),
34                              f"{feat}[0]={val}")]
35     for (feat, val) in initial_state.items()
36
37     # goal constraints on the final state:
38     constraints += [Constraint([feat_time_var[feat][number_stages]],
39                              is_(val),
40                              f"{feat}[{number_stages}]=val")]
41     for (feat, val) in goal.items()
42
43     # precondition constraints:
44     constraints += [Constraint([feat_time_var[feat][t],
45                               self.action_vars[t]],
46                          if_(val, act),
47                          f"{feat}[{t}]={val} if action[{t}]={act}")]
48     for act in prob_domain.actions
49     for (feat, val) in act.preconds.items()
50     for t in range(number_stages)
51
52     # effect constraints:
53     constraints += [Constraint([feat_time_var[feat][t+1],
54                               self.action_vars[t]],
55                          if_(val, act),
56                          f"{feat}[{t+1}]={val} if action[{t}]={act}")]
57     for act in prob_domain.actions
58     for (feat, val) in act.effects.items()
59     for t in range(number_stages)
60
61     # frame constraints:
62     constraints += [Constraint([feat_time_var[feat][t],
63                               self.action_vars[t], feat_time_var[feat][t+1]],
64                          eq_if_not_in_({act for act in
65                                          prob_domain.actions
66                                          if feat in act.effects}),
67                          f"{feat}[t]={feat}[t+1] if act not in
68                          {set(act for act in prob_domain.actions
69                              if feat in act.effects)}")]
69     for (feat, val) in prob_domain.feature_domain_dict.items()
70     for t in range(number_stages) ]
71
72     variables = set(self.action_vars) | {feat_time_var[feat][t]
73                                         for feat in

```

```

66         prob_domain.feature_domain_dict
67         for t in range(number_stages+1)}
68     CSP.__init__(self, "CSP_from_Strips", variables, constraints)
69
70     def extract_plan(self, soln):
71         return [soln[a] for a in self.action_vars]

```

The following methods return methods which can be applied to the particular environment.

For example, `is_(3)` returns a function that when applied to 3, returns True and when applied to any other value returns False. So `is_(3)(3)` returns True and `is_(3)(7)` returns False.

Note that the underscore ('_') is part of the name; we use the convention that a function with name ending in underscore returns a function. Commented out is an alternative style to define `is_` and `if_`; returning a function defined by lambda is equivalent to returning the embedded function, except that the embedded function has a name. The embedded function can also be given a docstring.

```

stripsCSPPlanner.py — (continued)
72 def is_(val):
73     """returns a function that is true when it is it applied to val.
74     """
75     #return lambda x: x == val
76     def is_fun(x):
77         return x == val
78     is_fun.__name__ = f"value_is_{val}"
79     return is_fun
80
81 def if_(v1,v2):
82     """if the second argument is v2, the first argument must be v1"""
83     #return lambda x1,x2: x1==v1 if x2==v2 else True
84     def if_fun(x1,x2):
85         return x1==v1 if x2==v2 else True
86     if_fun.__name__ = f"if x2 is {v2} then x1 is {v1}"
87     return if_fun
88
89 def eq_if_not_in_(actset):
90     """first and third arguments are equal if action is not in actset"""
91     # return lambda x1, a, x2: x1==x2 if a not in actset else True
92     def eq_if_not_fun(x1, a, x2):
93         return x1==x2 if a not in actset else True
94     eq_if_not_fun.__name__ = f"first and third arguments are equal if
95         action is not in {actset}"
96     return eq_if_not_fun

```

Putting it together, this returns a list of actions that solves the problem for a given horizon. If you want to do more than just return the list of actions, you might want to get it to return the solution. Or even enumerate the solutions (by using `Search_with_AC_from_CSP`).

```

stripsCSPPlanner.py — (continued)
97 def con_plan(prob,horizon):
98     """finds a plan for problem prob given horizon.
99     """
100     csp = CSP_from_STRIPES(prob, horizon)
101     sol = Con_solver(csp).solve_one()
102     return csp.extract_plan(sol) if sol else sol

```

The following are some example queries.

```

stripsCSPPlanner.py — (continued)
104 from searchGeneric import Searcher
105 from cspConsistency import Search_with_AC_from_CSP, Con_solver
106 from stripsProblem import Planning_problem
107 import stripsProblem
108
109 # Problem 0
110 # con_plan(stripsProblem.problem0,1) # should it succeed?
111 # con_plan(stripsProblem.problem0,2) # should it succeed?
112 # con_plan(stripsProblem.problem0,3) # should it succeed?
113 # To use search to enumerate solutions
114 #searcher0a =
115     Searcher(Search_with_AC_from_CSP(CSP_from_STRIPES(stripsProblem.problem0,
116     1)))
117 #print(searcher0a.search()) # returns path to solution
118
119 ## Problem 1
120 # con_plan(stripsProblem.problem1,5) # should it succeed?
121 # con_plan(stripsProblem.problem1,4) # should it succeed?
122 ## To use search to enumerate solutions:
123 #searcher15a =
124     Searcher(Search_with_AC_from_CSP(CSP_from_STRIPES(stripsProblem.problem1,
125     5)))
126 #print(searcher15a.search()) # returns path to solution
127
128 ## Problem 2
129 #con_plan(stripsProblem.problem2, 6) # should fail??
130 #con_plan(stripsProblem.problem2, 7) # should succeed???
131
132 ## Example 6.13
133 problem3 = Planning_problem(stripsProblem.delivery_domain,
134     {'SWC':True, 'RHC':False}, {'SWC':False})
135 #con_plan(problem3,2) # Horizon of 2
136 #con_plan(problem3,3) # Horizon of 3
137
138 problem4 = Planning_problem(stripsProblem.delivery_domain,{'SWC':True},
139     {'SWC':False, 'MW':False, 'RHM':False})
140
141 # For the stochastic local search:
142 #from cspSLS import SLSearcher, Runtime_distribution

```

```

139 # cspplanning15 = CSP_from_STRIPs(stripsProblem.problem1, 5) # should
      succeed
140 #se0 = SLSearcher(cspplanning15); print(se0.search(100000,0.5))
141 #p = Runtime_distribution(cspplanning15)
142 #p.plot_runs(1000,1000,0.7) # warning may take a few minutes

```

6.5 Partial-Order Planning

To run the demo, in folder "aipython", load "stripsPOP.py", and copy and paste the commented-out example queries at the bottom of that file.

A partial order planner maintains a partial order of action instances. An action instance consists of a name and an index. You need action instances because the same action could be carried out at different times.

```

-----stripsPOP.py — Partial-order Planner using STRIPS representation-----
11 from searchProblem import Arc, Search_problem
12 import random
13
14 class Action_instance(object):
15     next_index = 0
16     def __init__(self,action,index=None):
17         if index is None:
18             index = Action_instance.next_index
19             Action_instance.next_index += 1
20         self.action = action
21         self.index = index
22
23     def __str__(self):
24         return f"{self.action}#{self.index}"
25
26     __repr__ = __str__ # __repr__ function is the same as the __str__
      function

```

A partial-order planner is represented as a search problem (Section 3.1) where a node consists of:

- actions: a set of action instances.
- constraints: a set of (a_1, a_2) pairs, where a_1 and a_2 are action instances, which represents that a_1 must come before a_2 in the partial order. There are a number of ways that this could be represented. The code below represents the set of pairs that are in transitive closure of the *before* relation. This lets it quickly determine whether some *before* relation is consistent with the current constraints, at the cost of pre-computing and storing the transitive closure.

- *agenda*: a list of (s, a) pairs, where s is a (var, val) pair and a is an action instance. This means that variable var must have value val before a can occur.
- *causal_links*: a set of (a_0, g, a_1) triples, where a_1 and a_2 are action instances and g is a (var, val) pair. This holds when action a_0 makes g true for action a_1 .

stripsPOP.py — (continued)

```

28 class POP_node(object):
29     """a (partial) partial-order plan. This is a node in the search
30     space."""
31     def __init__(self, actions, constraints, agenda, causal_links):
32         """
33         * actions is a set of action instances
34         * constraints a set of (a0,a1) pairs, representing a0<a1,
35         closed under transitivity
36         * agenda list of (subgoal,action) pairs to be achieved, where
37         subgoal is a (variable,value) pair
38         * causal_links is a set of (a0,g,a1) triples,
39         where ai are action instances, and g is a (variable,value) pair
40         """
41         self.actions = actions # a set of action instances
42         self.constraints = constraints # a set of (a0,a1) pairs
43         self.agenda = agenda # list of (subgoal,action) pairs to be
44         achieved
45         self.causal_links = causal_links # set of (a0,g,a1) triples
46
47     def __str__(self):
48         return ("actions: "+str({str(a) for a in self.actions})+
49             "\nconstraints: "+
50             str({(str(a1),str(a2)) for (a1,a2) in self.constraints})+
51             "\nagenda: "+
52             str([(str(s),str(a)) for (s,a) in self.agenda])+
53             "\ncausal_links:"+
54             str({(str(a0),str(g),str(a2)) for (a0,g,a2) in
55                 self.causal_links}) )

```

`extract_plan` constructs a total order of action instances that is consistent with the partial order.

stripsPOP.py — (continued)

```

54 def extract_plan(self):
55     """returns a total ordering of the action instances consistent
56     with the constraints.
57     raises IndexError if there is no choice.
58     """
59     sorted_acts = []
60     other_acts = set(self.actions)
61     while other_acts:

```

```

62         a = random.choice([a for a in other_acts if
63                             all(((a1,a) not in self.constraints) for a1 in
                                other_acts)])
64         sorted_acts.append(a)
65         other_acts.remove(a)
66     return sorted_acts

```

POP_search_from_STRIPS is an instance of a search problem. As such, it needs start nodes, a goal, and the neighbors function.

```

-----stripsPOP.py --- (continued)-----
68 from display import Displayable
69
70 class POP_search_from_STRIPS(Search_problem, Displayable):
71     def __init__(self,planning_problem):
72         Search_problem.__init__(self)
73         self.planning_problem = planning_problem
74         self.start = Action_instance("start")
75         self.finish = Action_instance("finish")
76
77     def is_goal(self, node):
78         return node.agenda == []
79
80     def start_node(self):
81         constraints = {(self.start, self.finish)}
82         agenda = [(g, self.finish) for g in
                    self.planning_problem.goal.items()]
83         return POP_node([self.start,self.finish], constraints, agenda, [] )

```

The neighbors method enumerates the neighbors of a given node, using yield.

```

-----stripsPOP.py --- (continued)-----
85     def neighbors(self, node):
86         """enumerates the neighbors of node"""
87         self.display(3,"finding neighbors of\n",node)
88         if node.agenda:
89             subgoal,act1 = node.agenda[0]
90             self.display(2,"selecting",subgoal,"for",act1)
91             new_agenda = node.agenda[1:]
92             for act0 in node.actions:
93                 if (self.achieves(act0, subgoal) and
94                     self.possible((act0,act1),node.constraints)):
95                     self.display(2," reusing",act0)
96                     const1 =
97                         self.add_constraint((act0,act1),node.constraints)
98                     new_clink = (act0,subgoal,act1)
99                     new_cls = node.causal_links + [new_clink]
100                    for const2 in
                        self.protect_cl_for_actions(node.actions,const1,new_clink):
                            yield Arc(node,

```

```

101         POP_node(node.actions,consts2,new_agenda,new_cls),
102         cost=0)
103     for a0 in self.planning_problem.prob_domain.actions: #a0 is an
104         action
105         if self.achieves(a0, subgoal):
106             #a0 achieves subgoal
107             new_a = Action_instance(a0)
108             self.display(2," using new action",new_a)
109             new_actions = node.actions + [new_a]
110             consts1 =
111                 self.add_constraint((self.start,new_a),node.constraints)
112             consts2 = self.add_constraint((new_a,act1),consts1)
113             new_agenda1 = new_agenda + [(pre,new_a) for pre in
114                 a0.preconds.items()]
115             new_clink = (new_a,subgoal,act1)
116             new_cls = node.causal_links + [new_clink]
117             for consts3 in
118                 self.protect_all_cls(node.causal_links,new_a,consts2):
119                 for consts4 in
120                     self.protect_cl_for_actions(node.actions,consts3,new_clink):
121                     yield Arc(node,
122                             POP_node(new_actions,consts4,new_agenda1,new_cls),
123                             cost=1)

```

Given a causal link $(a0, subgoal, a1)$, the following method protects the causal link from each action in *actions*. Whenever an action deletes *subgoal*, the action needs to be before *a0* or after *a1*. This method enumerates all constraints that result from protecting the causal link from all actions.

stripsPOP.py — (continued)

```

120     def protect_cl_for_actions(self, actions, constra, clink):
121         """yields constraints that extend constra and
122         protect causal link (a0, subgoal, a1)
123         for each action in actions
124         """
125         if actions:
126             a = actions[0]
127             rem_actions = actions[1:]
128             a0, subgoal, a1 = clink
129             if a != a0 and a != a1 and self.deletes(a,subgoal):
130                 if self.possible((a,a0),constra):
131                     new_const = self.add_constraint((a,a0),constra)
132                     for e in
133                         self.protect_cl_for_actions(rem_actions,new_const,clink):
134                         yield e # could be "yield from"
135                 if self.possible((a1,a),constra):
136                     new_const = self.add_constraint((a1,a),constra)
137                     for e in
138                         self.protect_cl_for_actions(rem_actions,new_const,clink):
139                         yield e
140         else:

```

```

137         for e in
            self.protect_cl_for_actions(rem_actions,constrs,clink):
                yield e
138     else:
139         yield constrs

```

Given an action *act*, the following method protects all the causal links in *clinks* from *act*. Whenever *act* deletes *subgoal* from some causal link (*a0*, *subgoal*, *a1*), the action *act* needs to be before *a0* or after *a1*. This method enumerates all constraints that result from protecting the causal links from *act*.

```

_____stripsPOP.py — (continued)_____
141 def protect_all_cls(self, clinks, act, constrs):
142     """yields constraints that protect all causal links from act"""
143     if clinks:
144         (a0,cond,a1) = clinks[0] # select a causal link
145         rem_clinks = clinks[1:] # remaining causal links
146         if act != a0 and act != a1 and self.deletes(act,cond):
147             if self.possible((act,a0),constrs):
148                 new_const = self.add_constraint((act,a0),constrs)
149                 for e in self.protect_all_cls(rem_clinks,act,new_const):
150                     yield e
151             if self.possible((a1,act),constrs):
152                 new_const = self.add_constraint((a1,act),constrs)
153                 for e in self.protect_all_cls(rem_clinks,act,new_const):
154                     yield e
155         else:
156             for e in self.protect_all_cls(rem_clinks,act,constrs): yield
157                 e
158     else:
159         yield constrs

```

The following methods check whether an action (or action instance) achieves or deletes some subgoal.

```

_____stripsPOP.py — (continued)_____
158 def achieves(self,action,subgoal):
159     var,val = subgoal
160     return var in self.effects(action) and self.effects(action)[var] ==
161         val
162
163 def deletes(self,action,subgoal):
164     var,val = subgoal
165     return var in self.effects(action) and self.effects(action)[var] !=
166         val
167
168 def effects(self,action):
169     """returns the variable:value dictionary of the effects of action.
170     works for both actions and action instances"""
171     if isinstance(action, Action_instance):
172         action = action.action

```

```

171     if action == "start":
172         return self.planning_problem.initial_state
173     elif action == "finish":
174         return {}
175     else:
176         return action.effects

```

The constraints are represented as a set of pairs closed under transitivity. Thus if (a, b) and (b, c) are the list, then (a, c) must also be in the list. This means that adding a new constraint means adding the implied pairs, but querying whether some order is consistent is quick.

```

stripsPOP.py — (continued)
178     def add_constraint(self, pair, const):
179         if pair in const:
180             return const
181         todo = [pair]
182         newconst = const.copy()
183         while todo:
184             x0,x1 = todo.pop()
185             newconst.add((x0,x1))
186             for x,y in newconst:
187                 if x==x1 and (x0,y) not in newconst:
188                     todo.append((x0,y))
189                 if y==x0 and (x,x1) not in newconst:
190                     todo.append((x,x1))
191         return newconst
192
193     def possible(self,pair,constraint):
194         (x,y) = pair
195         return (y,x) not in constraint

```

Some code for testing:

```

stripsPOP.py — (continued)
197 from searchBranchAndBound import DF_branch_and_bound
198 from searchMPP import SearcherMPP
199 import stripsProblem
200
201 rplanning0 = POP_search_from_STRIPS(stripsProblem.problem0)
202 rplanning1 = POP_search_from_STRIPS(stripsProblem.problem1)
203 rplanning2 = POP_search_from_STRIPS(stripsProblem.problem2)
204 searcher0 = DF_branch_and_bound(rplanning0,5)
205 searcher0a = SearcherMPP(rplanning0)
206 searcher1 = DF_branch_and_bound(rplanning1,10)
207 searcher1a = SearcherMPP(rplanning1)
208 searcher2 = DF_branch_and_bound(rplanning2,10)
209 searcher2a = SearcherMPP(rplanning2)
210 # Try one of the following searchers
211 # a = searcher0.search()
212 # a = searcher0a.search()

```

```
213 # a.end().extract_plan() # print a plan found
214 # a.end().constraints # print the constraints
215 # SearcherMPP.max_display_level = 0 # less detailed display
216 # DF_branch_and_bound.max_display_level = 0 # less detailed display
217 # a = searcher1.search()
218 # a = searcher1a.search()
219 # a = searcher2.search()
220 # a = searcher2a.search()
```

Supervised Machine Learning

This first chapter on machine learning covers the following topics:

- Data: how to load it, splitting into training, validation and test sets
- Features: many of the features come directly from the data. Sometimes it is useful to construct features, e.g. $height > 1.9m$ might be a Boolean feature constructed from the real-values feature *height*. The next chapter is about neural networks and how to learn features; the code in this chapter constructs them explicitly in what is often known as **feature engineering**.
- Learning with no input features: this is the base case of many methods. What should you predict if you have no input features? This provides the base cases for many algorithms (e.g., decision tree algorithm) and baselines that more sophisticated algorithms need to beat. It also provides ways to test various predictors.
- Decision tree learning: one of the classic and simplest learning algorithms, which is the basis of many other algorithms.
- Cross validation and parameter tuning: methods to prevent overfitting.
- Linear regression and classification: other classic and simple techniques that often work well (particularly combined with feature learning or engineering).
- Boosting: combining simpler learning methods to make even better learners.

A good source of classic datasets is the UCI Machine Learning Repository <https://archive.ics.uci.edu/datasets> [Lichman, 2013] [Dua and Graff, 2017]. The SPECT, IRIS, and car datasets (carbool is a Boolean version of the car dataset) are from this repository.

Dataset	# Examples	#Columns	Input Types	Target Type
SPECT	267	23	Boolean	Boolean
IRIS	150	5	numeric	categorical
car	1728	7	categorical/numeric	categorical
carbool	1728	7	categorical/numeric	Boolean
holiday	32	6	Boolean	Boolean
mail_reading	28	5	Boolean	Boolean
tv_likes	12	5	Boolean	Boolean
simp_regr	7	2	numeric	numeric

Figure 7.1: Some of the datasets used here.

7.1 Representations of Data and Predictions

The code uses the following definitions and conventions:

- A **dataset** is an enumeration of examples.
- An **example** is a list (or tuple) of values. The values can be numbers or strings.
- A **feature** is a function from examples into the range of the feature. Each feature f also has the following attributes:

$f.f\text{type}$, the type of f , one of: "boolean", "categorical", "numeric"

$f.f\text{range}$, the set of values of f seen in the dataset, represented as a list.

The $f\text{type}$ is inferred from the $f\text{range}$ if not given explicitly.

$f.__\text{doc}___$, the docstring, a string description of f (for printing).

Thus for example, a **Boolean feature** is a function from the examples into $\{False, True\}$. So, if f is a Boolean feature, $f.f\text{range} == [False, True]$, and if e is an example, $f(e)$ is either *True* or *False*.

```

learnProblem.py — A Learning Problem
11 import math, random, statistics
12 import csv
13 from display import Displayable
14 from utilities import argmax
15
16 boolean = [False, True]

```

A dataset is partitioned into a training set (train), a validation set (valid) and a test set (test). The target feature is the feature that a learner making a prediction of. A dataset ds has the following attributes:

$ds.train$ a list of the training examples

$ds.valid$ a list of the validation examples

`ds.test` a list of the test examples

`ds.target_index` the index of the target

`ds.target` the feature corresponding to the target (a function from examples to target value)

`ds.input_features` a list of the input features

learnProblem.py — (continued)

```

18 class Data_set(Displayable):
19     """ A dataset consists of a list of training data and a list of test
20         data.
21     """
22     def __init__(self, train, test=None, target_index=0,
23                 prob_test=0.10, prob_valid=0.11,
24                 num_properties=None, header=None, target_type=None,
25                 one_hot=False, seed=None):
26         """A dataset for learning.
27         train is a list of tuples representing the training examples
28         test is the list of tuples representing the test examples
29         if test is None, a test set is created by selecting each
30             example with probability prob_test
31         target_index is the index of the target.
32             If negative, it counts from right.
33             If target_index is larger than the number of properties,
34             there is no target (for unsupervised learning)
35         prob_valid probability a non-test example is in validation set
36         num_properties is the number of properties (columns), if None, get
37             from training set
38         header is a list of names for the features
39         target_type is either None for automatic detection of target type
40             or one of "numeric", "boolean", "categorical"
41         one_hot is True gives a one-hot encoding of categorical features
42         seed is for random number; None gives a different test set each time
43         """
44         if seed: # given seed makes partition consistent from run-to-run
45             random.seed(seed)
46         self.prob_test = prob_test
47         if test is None:
48             train,test = partition_data(train, prob_test)
49             self.train, self.valid = partition_data(train, prob_valid)
50             self.test = test
51
52         self.display(1,"Training set has",len(self.train),"examples. Number
53             of columns: ",{len(e) for e in self.train})
54         self.display(1,"Test set has",len(test),"examples. Number of
55             columns: ",{len(e) for e in test})
56         self.display(1,"Validation set has",len(self.valid),"examples.
57             Number of columns: ",{len(e) for e in self.valid})

```

```

54     if num_properties is None:
55         self.num_properties = len(self.train[0])
56     else:
57         self.num_properties = num_properties
58     if target_index < 0: #allows for -1, -2, etc.
59         self.target_index = self.num_properties + target_index
60     else:
61         self.target_index = target_index
62     self.header = header
63     self.domains = [set() for i in range(self.num_properties)]
64     for example in self.train:
65         for ind, val in enumerate(example):
66             self.domains[ind].add(val)
67     self.conditions_cache = {} # cache for computed conditions
68     self.create_features(one_hot)
69     if target_type:
70         self.target.ftype = target_type
71     self.display(1, "There are", len(self.input_features), "input
72         features")
73
74     def __str__(self):
75         if self.train and len(self.train)>0: # has training examples
76             return (f"Data: {len(self.train)} training, {len(self.valid)}
77                 validation"
78                     f"{len(self.test)} test examples; {len(self.train[0])}
79                     features.")
80         else:
81             return (f"Data: {len(self.train)} training, {len(self.valid)}
82                 validation"
83                     f"{len(self.test)} test examples")

```

A **feature** is a function that takes an example and returns a value in the range of the feature. Each feature has a **frange**, which gives the range of the feature, and an **ftype** that gives the type, one of "boolean", "numeric" or "categorical".

learnProblem.py — (continued)

```

81     def create_features(self, one_hot=False):
82         """create the set of features.
83         if one_hot==True makes categorical input features into Booleans
84         """
85         self.target = None
86         self.input_features = []
87         for i in range(self.num_properties):
88             frange = list(self.domains[i])
89             ftype = self.infer_type(frange)
90             if one_hot and ftype == "categorical" and i !=
91                 self.target_index:
92                 for val in frange:
93                     def feat(e, index=i, val=val):
94                         return e[index]==val

```

```

94         if self.header:
95             feat.__doc__ = self.header[i]+"="+val
96         else:
97             feat.__doc__ = f"e[{i}]={val}"
98             feat.frange = boolean
99             feat.type = "boolean"
100            self.input_features.append(feat)
101    else:
102        def feat(e,index=i):
103            return e[index]
104        if self.header:
105            feat.__doc__ = self.header[i]
106        else:
107            feat.__doc__ = "e["+str(i)+"]"
108        feat.frange = frange
109        feat.ftype = ftype
110        if i == self.target_index:
111            self.target = feat
112        else:
113            self.input_features.append(feat)

```

The following tries to infer the type of each feature. Sometimes this can be wrong, (e.g., when the numbers are really categorical) and may need to be set explicitly.

```

_____learnProblem.py — (continued) _____
115    def infer_type(self, domain):
116        """Infers the type of a feature with domain
117        """
118        if all(v in {True,False} for v in domain) or all(v in {0,1} for v
119            in domain):
120            return "boolean"
121        if all(isinstance(v,(float,int)) for v in domain):
122            return "numeric"
123        else:
124            return "categorical"

```

7.1.1 Creating Boolean Conditions from Features

Some of the algorithms require Boolean input features (features with range $\{0,1\}$). In order to be able to use these algorithms on datasets with arbitrary domains of input variables, the following code constructs Boolean conditions from the attributes.

There are 3 cases:

- When the range only has two values, one is designated to be the “true” value.
- When the values are all numeric, assume they are ordered (as opposed to just being some classes that happen to be labelled with numbers) and

construct Boolean features for splits of the data. That is, the feature is $e[ind] < cut$ for some value cut . The number of cut values is less than or equal to `max_num_cuts`.

- When the values are not all numeric, it creates an indicator function for each value. An indicator function for a value returns true when that value is given and false otherwise. Note that we can't create an indicator function for values that appear in the test set but not in the training or validation sets because we haven't seen the test set. For the examples in the test set with a value that doesn't appear in the training set for that feature, the indicator functions all return false.

There is also an option `categorical_only` to create only Boolean features for categorical input features, and not to make cuts for numerical values.

```

learnProblem.py — (continued)
125 def conditions(self, max_num_cuts=8, categorical_only = False):
126     """returns a list of boolean conditions from the input features
127     max_num_cuts: maximum number of cuts for numeric features
128     categorical_only: only categorical features are made binary
129     """
130     if (max_num_cuts, categorical_only) in self.conditions_cache:
131         return self.conditions_cache[(max_num_cuts, categorical_only)]
132     conds = []
133     for ind, frange in enumerate(self.domains):
134         if ind != self.target_index and len(frange)>1:
135             if len(frange) == 2:
136                 # two values, the feature is equality to one of them.
137                 true_val = list(frange)[1] # choose one as true
138                 def feat(e, i=ind, tv=true_val):
139                     return e[i]==tv
140                 if self.header:
141                     feat.__doc__ = f"{self.header[ind]}=={true_val}"
142                 else:
143                     feat.__doc__ = f"e[{ind]}=={true_val}"
144                 feat.frange = frange
145                 feat.ftype = "boolean"
146                 conds.append(feat)
147             elif all(isinstance(val, (int, float)) for val in frange):
148                 if categorical_only: # numeric, don't make cuts
149                     def feat(e, i=ind):
150                         return e[i]
151                     feat.__doc__ = f"e[{ind]}"
152                     conds.append(feat)
153                 else:
154                     # all numeric, create cuts of the data
155                     sorted_frange = sorted(frange)
156                     num_cuts = min(max_num_cuts, len(frange))
157                     cut_positions = [len(frange)*i//num_cuts for i in
                                     range(1, num_cuts)]

```

```

158         for cut in cut_positions:
159             cutat = sorted_frange[cut]
160             def feat(e, ind_=ind, cutat=cutat):
161                 return e[ind_] < cutat
162
163             if self.header:
164                 feat.__doc__ = self.header[ind]+"<" +str(cutat)
165             else:
166                 feat.__doc__ = "e["+str(ind)+"]<" +str(cutat)
167             feat.frange = boolean
168             feat.ftype = "boolean"
169             conds.append(feat)
170     else:
171         # create an indicator function for every value
172         for val in frange:
173             def feat(e, ind_=ind, val_=val):
174                 return e[ind_] == val_
175             if self.header:
176                 feat.__doc__ = self.header[ind]+"==" +str(val)
177             else:
178                 feat.__doc__ = "e["+str(ind)+"]==" +str(val)
179             feat.frange = boolean
180             feat.ftype = "boolean"
181             conds.append(feat)
182     self.conditions_cache[(max_num_cuts, categorical_only)] = conds
183     return conds

```

Exercise 7.1 Change the code so that it splits using $e[ind] \leq cut$ instead of $e[ind] < cut$. Check boundary cases, such as 3 elements with 2 cuts. As a test case, make sure that when the range is the 30 integers from 100 to 129, and you want 2 cuts, the resulting Boolean features should be $e[ind] \leq 109$ and $e[ind] \leq 119$ to make sure that each of the resulting domains is of equal size.

Exercise 7.2 This splits on whether the feature is less than one of the values in the training set. Sam suggested it might be better to split between the values in the training set, and suggested using

$$cutat = (sorted_frange[cut] + sorted_frange[cut - 1])/2$$

Why might Sam have suggested this? Does this work better? (Try it on a few datasets).

7.1.2 Evaluating Predictions

A **predictor** is a function that takes an example and makes a prediction on the values of the target features.

A **loss** takes a prediction and the actual value and returns a non-negative real number; lower is better. The **error** for a dataset is either the mean loss, or sometimes the sum of the losses; they differ by a constant (the number of

examples). When reporting results the mean is usually used, as it can be interpreted independently of the dataset size. When it is the sum, this will be made explicit.

The function `evaluate_dataset` returns the average error for each example, where the error for each example depends on the evaluation criteria.

```

learnProblem.py — (continued)
185     def evaluate_dataset(self, data, predictor, error_measure):
186         """Evaluates predictor on data according to the error_measure
187         predictor is a function that takes an example and returns a
188             prediction for the target features.
189         error_measure(prediction,actual) -> non-negative real
190         """
191         if data:
192             try:
193                 value = statistics.mean(error_measure(predictor(e),
194                                     self.target(e))
195                                     for e in data)
196             except ValueError: # if error_measure gives an error
197                 return float("inf") # infinity
198             return value
199         else:
200             return math.nan # not a number

```

Three losses are implemented: the squared or L2 loss (average of the square of the difference between the actual and predicted values), absolute or L1 loss (average of the absolute difference between the actual and predicted values) and the log loss (the average negative log-likelihood, which can be interpreted as the number of bits to describe an example using a code based on the prediction treated as a probability). The accuracy is also defined, but it is not a loss as it should be maximized.

This is defined using a class, `Evaluate` but no instances will be created. Just use `Evaluate.squared_loss` etc. (Please keep the `__doc__` strings a consistent length as they are used in tables.) The prediction is either a real value or a `{value : probability}` dictionary or a list. The actual is either a real number or a key of the prediction.

```

learnProblem.py — (continued)
201 class Evaluate(object):
202     """A container for the evaluation measures"""
203
204     def squared_loss(prediction, actual):
205         "squared loss "
206         if isinstance(prediction, (list,dict)):
207             return (1-prediction[actual])**2 # the correct value is 1
208         else:
209             return (prediction-actual)**2
210
211     def absolute_loss(prediction, actual):

```

```

212     "absolute loss "
213     if isinstance(prediction, (list,dict)):
214         return abs(1-prediction[actual]) # the correct value is 1
215     else:
216         return abs(prediction-actual)
217
218 def log_loss(prediction, actual):
219     "log loss (bits)"
220     try:
221         if isinstance(prediction, (list,dict)):
222             return -math.log2(prediction[actual])
223         else:
224             return -math.log2(prediction) if actual==1 else
                -math.log2(1-prediction)
225     except ValueError:
226         return float("inf") # infinity
227
228 def accuracy(prediction, actual):
229     "accuracy      "
230     return themode(prediction) == actual
231
232     all_criteria = [accuracy, absolute_loss, squared_loss, log_loss]
233
234 def themode(prediction):
235     """the mode of a prediction. Used for accuracy.
236     This handles all of the cases of AIPython predictors: dictionaries,
237     lists and real predictions (for integer/booleans).
238     """
239     if isinstance(prediction, dict):
240         md, val = None, -math.inf
241         for (p,v) in prediction.items():
242             if v> val:
243                 md, val = p,v
244         return md
245     if isinstance(prediction, list):
246         md,val = 0,prediction[0]
247         for i in range(1,len(prediction)):
248             if prediction[i]>val:
249                 md,val = i,prediction[i]
250         return md
251     else: # prediction is real number; round to nearest integer
252         return round(prediction)

```

7.1.3 Creating Test and Training Sets

The following method partitions the data into a training set and a test set. (Also training into training and validation sets). Note that this does not guarantee that the test set will contain exactly a proportion of the data equal to prob_test.

[An alternative is to use `random.sample()` which can guarantee that the test

set will contain exactly a particular proportion of the data. However this would require knowing how many elements are in the dataset, which it may not know, as data may just be a generator of the data (e.g., when reading the data from a file.)]

```

learnProblem.py — (continued)
253 def partition_data(data, prob_test=0.30):
254     """partitions the data into a training set and a test set, where
255     prob_test is the probability of each example being in the test set.
256     """
257     train = []
258     test = []
259     for example in data:
260         if random.random() < prob_test:
261             test.append(example)
262         else:
263             train.append(example)
264     return train, test

```

7.1.4 Importing Data From File

A dataset is typically loaded from a file. The default here is that it loaded from a CSV (comma separated values) file, although the separator can be changed. This assumes that all lines that contain the separator are valid data (so it only includes those data items that contain more than one element). This allows for blank lines and comment lines that do not contain the separator. However, it means that this method is not suitable for cases where there is only one feature.

Note that *data_all* and *data_tuples* are generators. *data_all* is a generator of a list of list of strings. This version assumes that CSV files are simple. The standard `csv` package, that allows quoted arguments, can be used by uncommenting the line for *data_all* and commenting out the line that follows. *data_tuples* contains only those lines that contain the delimiter (others lines are assumed to be empty or comments), and tries to convert the elements to numbers whenever possible.

```

learnProblem.py — (continued)
266 class Data_from_file(Data_set):
267     def __init__(self, file_name, separator=',', num_train=None,
268                 prob_test=0.10, prob_valid=0.11,
269                 has_header=False, target_index=0, one_hot=False,
270                 categorical=[], target_type=None, seed=None):
271         """create a dataset from a file
272         separator is the character that separates the attributes (',' for
273         CSV file)
274         num_train is a number specifying the first num_train tuples are
275         training, or None
276         prob_test is the probability each example is in the test set (if
277         num_train is None)

```

```

274     prob_valid is the probability each non-test example is in the
        validation set
275     has_header is True if the first line of file is a header
276     target_index specifies which feature is the target
277     one_hot specifies whether categorical features should be encoded as
        one_hot.
278     categorical is a set (or list) of features that should be treated
        as categorical
279     target_type is either None for automatic detection of target type
        or one of "numeric", "boolean", "categorical"
280     """
281
282     with open(file_name, 'r', newline='') as csvfile:
283         self.display(1, "Loading", file_name)
284         # data_all = csv.reader(csvfile, delimiter=separator) # for
            more complicated CSV files
285         data_all = (line.strip().split(separator) for line in csvfile)
286         if has_header:
287             header = next(data_all)
288         else:
289             header = None
290         data_tuples = (interpret_elements(d) for d in data_all if
            len(d)>1)
291         if num_train is not None:
292             # training set is divided into training then text examples
293             # the file is only read once, and the data is placed in
                appropriate list
294             train = []
295             for i in range(num_train): # will give an error if
                insufficient examples
296                 train.append(next(data_tuples))
297             test = list(data_tuples)
298             Data_set.__init__(self, train, test=test,
                prob_valid=prob_valid,
299                             target_index=target_index, header=header,
                seed=seed,
300                             target_type=target_type, one_hot=one_hot)
301         else: # randomly assign training and test examples
302             Data_set.__init__(self, data_tuples, test=None,
                prob_test=prob_test, prob_valid=prob_valid,
303                             target_index=target_index, header=header,
                seed=seed,
304                             target_type=target_type, one_hot=one_hot)

```

The following class is used for datasets where the training and test are in different files

learnProblem.py — (continued)

```

306 class Data_from_files(Data_set):
307     def __init__(self, train_file_name, test_file_name, separator=',',
308                 has_header=False, target_index=0, one_hot=False,
309                 categorical=[], target_type= None):

```

```

310 """create a dataset from separate training and file
311 separator is the character that separates the attributes
312 num_train is a number specifying the first num_train tuples are
      training, or None
313 prob_test is the probability an example should in the test set (if
      num_train is None)
314 has_header is True if the first line of file is a header
315 target_index specifies which feature is the target
316 one_hot specifies whether categorical features should be encoded as
      one-hot
317 categorical is a set (or list) of features that should be treated
      as categorical
318 target_type is either None for automatic detection of target type
319 or one of "numeric", "boolean", "categorical"
320 """
321 with open(train_file_name,'r',newline='') as train_file:
322     with open(test_file_name,'r',newline='') as test_file:
323         # data_all = csv.reader(csvfile,delimiter=separator) # for more
          complicated CSV files
324         train_data = (line.strip().split(separator) for line in
          train_file)
325         test_data = (line.strip().split(separator) for line in
          test_file)
326         if has_header: # this assumes the training file has a header
          and the test file doesn't
327             header = next(train_data)
328         else:
329             header = None
330         train_tuples = [interpret_elements(d) for d in train_data if
          len(d)>1]
331         test_tuples = [interpret_elements(d) for d in test_data if
          len(d)>1]
332         Data_set.__init__(self,train_tuples, test_tuples,
333                           target_index=target_index, header=header,
          one_hot=one_hot)

```

When reading from a file all of the values are strings. This next method tries to convert each value into a number (an int or a float) or Boolean, if it is possible.

```

_____learnProblem.py — (continued) _____
335 def interpret_elements(str_list):
336     """make the elements of string list str_list numeric if possible.
337     Otherwise remove initial and trailing spaces.
338     """
339     res = []
340     for e in str_list:
341         try:
342             res.append(int(e))
343         except ValueError:
344             try:

```

```

345         res.append(float(e))
346     except ValueError:
347         se = e.strip()
348         if se in ["True", "true", "TRUE"]:
349             res.append(True)
350         elif se in ["False", "false", "FALSE"]:
351             res.append(False)
352         else:
353             res.append(e.strip())
354     return res

```

7.1.5 Augmented Features

Sometimes we want to augment the features with new features computed from the old features (e.g., the product of features). The following code creates a new dataset from an old dataset but with new features. Note that special cases of these are **kernels**; mapping the original feature space into a new space, which allow a neat way to do learning in the augmented space for many mappings (the “kernel trick”). This is beyond the scope of AIPython; those interested should read about *support vector machines*.

Recall that a feature is a function of examples. A unary feature constructor takes a feature and returns a new feature. A binary feature combiner takes two features and returns a new feature.

```

learnProblem.py — (continued)
356 class Data_set_augmented(Data_set):
357     def __init__(self, dataset, unary_functions=[], binary_functions=[],
358                 include_orig=True):
359         """creates a dataset like dataset but with new features
360         unary_function is a list of unary feature constructors
361         binary_functions is a list of binary feature combiners.
362         include_orig specifies whether the original features should be
363         included
364         """
365         self.orig_dataset = dataset
366         self.unary_functions = unary_functions
367         self.binary_functions = binary_functions
368         self.include_orig = include_orig
369         self.target = dataset.target
370         Data_set.__init__(self, dataset.train, test=dataset.test,
371                           target_index = dataset.target_index)
372     def create_features(self, one_hot=False):
373         """create the set of features.
374         one_hot is ignored, but could be implemented as in
375         Data_set.create_features
376         """
377         if self.include_orig:
378             self.input_features = self.orig_dataset.input_features.copy()

```

```

377         else:
378             self.input_features = []
379         for u in self.unary_functions:
380             for f in self.orig_dataset.input_features:
381                 self.input_features.append(u(f))
382         for b in self.binary_functions:
383             for f1 in self.orig_dataset.input_features:
384                 for f2 in self.orig_dataset.input_features:
385                     if f1 != f2:
386                         self.input_features.append(b(f1,f2))

```

The following are useful unary feature constructors and binary feature combiner.

```

learnProblem.py — (continued)
388 def square(f):
389     """a unary feature constructor to construct the square of a feature
390     """
391     def sq(e):
392         return f(e)**2
393     sq.__doc__ = f.__doc__+"**2"
394     return sq
395
396 def power_feat(n):
397     """given n returns a unary feature constructor to construct the nth
398     power of a feature.
399     e.g., power_feat(2) is the same as square, defined above
400     """
401     def fn(f,n=n):
402         def pow(e,n=n):
403             return f(e)**n
404         pow.__doc__ = f.__doc__+"**"+str(n)
405         return pow
406     return fn
407
408 def prod_feat(f1,f2):
409     """a new feature that is the product of features f1 and f2
410     """
411     def feat(e):
412         return f1(e)*f2(e)
413     feat.__doc__ = f1.__doc__+"*" +f2.__doc__
414     return feat
415
416 def eq_feat(f1,f2):
417     """a new feature that is 1 if f1 and f2 give same value
418     """
419     def feat(e):
420         return 1 if f1(e)==f2(e) else 0
421     feat.__doc__ = f1.__doc__+"==" +f2.__doc__
422     return feat

```

```

423 def neq_feat(f1,f2):
424     """a new feature that is 1 if f1 and f2 give different values
425     """
426     def feat(e):
427         return 1 if f1(e)!=f2(e) else 0
428     feat.__doc__ = f1.__doc__+"!="+f2.__doc__
429     return feat

```

Example:

```

learnProblem.py — (continued)
431 # from learnProblem import Data_set_augmented,prod_feat
432 # data = Data_from_file('data/holiday.csv', has_header=True, num_train=19,
433     target_index=-1)
434 # data = Data_from_file('data/iris.data', prob_test=1/3, target_index=-1)
435 ## Data = Data_from_file('data/SPECT.csv', prob_test=0.5, target_index=0)
436 # dataplus = Data_set_augmented(data,[],[prod_feat])
437 # dataplus = Data_set_augmented(data,[],[prod_feat,neq_feat])

```

Exercise 7.3 For symmetric properties, such as product, we don't need both $f1 * f2$ as well as $f2 * f1$ as extra properties. Allow the user to be able to declare feature constructors as symmetric (by associating a Boolean feature with them). Change *construct_features* so that it does not create both versions for symmetric combiners.

7.2 Generic Learner Interface

A **learner** takes a dataset (and possibly other arguments specific to the method). To get it to learn, call the *learn()* method. This implements *Displayable* so that it can display traces at multiple levels of detail (perhaps with a GUI).

```

learnProblem.py — (continued)
437 from display import Displayable
438
439 class Learner(Displayable):
440     def __init__(self, dataset):
441         raise NotImplementedError("Learner.__init__") # abstract method
442
443     def learn(self):
444         """returns a predictor, a function from a tuple to a value for the
445         target feature
446         """
447         raise NotImplementedError("learn") # abstract method
448
449     def __str__(self, sig_dig=3):
450         """String representation of the learned predictor
451         """
452         return "no representation"

```

```

453 | def evaluate(self):
454 |     """Evaluates learner on training and test data
455 |     """
456 |     print(f"function learned is {self}")
457 |     print("Criterion\tTraining\tvalidation\ttest")
458 |     for ecrit in Evaluate.all_criteria:
459 |         print(ecrit.__doc__, end='\t')
460 |         for data_subset in [self.dataset.train, self.dataset.valid,
461 |                             self.dataset.test]:
462 |             error = self.dataset.evaluate_dataset(data_subset,
463 |                                                  self.predictor, ecrit)
464 |             print(str(round(error,7)), end='\t')
465 |     print()

```

7.3 Learning With No Input Features

If you need make the same prediction for each example (the input features are ignored), what prediction should you make? This can be used as a naive baseline; if a more sophisticated method does not do better than this, it is not useful. This also provides the base case for some methods, such as decision-tree learning.

To run demo to compare different prediction methods on various evaluation criteria, in folder "aipython", load "learnNoInputs.py", using e.g., `python -i learnNoInputs.py`, and it prints some test results.

There are a few alternatives as to what could be allowed in a prediction:

- a point prediction, where only allowed the values of the feature can predicted. For example, if the values of the feature are $\{0,1\}$ we are only allowed to predict 0 or 1 or of the values are ratings in $\{1,2,3,4,5\}$, we can only predict one of these integers.
- a point prediction, where any value can be predicted. For example, if the values of the feature are $\{0,1\}$ it could predict 0.3, 1, or even 1.7. For all of the criteria defined, there is no point in predicting a value greater than 1 or less than zero (but that doesn't mean it can't). If the values are ratings in $\{1,2,3,4,5\}$, you may want to predict 3.4.
- a probability distribution over the values of the feature. For each value v , it predicts a non-negative number p_v , such that the sum over all predictions is 1.

Here are some prediction functions that take in an enumeration of values, a domain, and returns a point prediction: a value or dictionary of $\{value : prediction\}$. Note that `cmmedian` returns one of the middle values when there are an even number of examples, whereas `median` gives the average of them

(and so `cmedian` is applicable for ordinals that cannot be considered cardinal values). Similarly, `cmode` picks one of the values when more than one value has the maximum number of elements.

```

learnNoInputs.py — Learning ignoring all input features
11 from learnProblem import Evaluate
12 import math, random, collections, statistics
13 import utilities # argmax for (element,value) pairs
14
15 class Predict(object):
16     """The class of prediction methods for a list of values.
17     The doc strings the same length because they are used in tables.
18     Note that the methods don't have the self argument.
19     To use call Predict.laplace(data) etc."""
20
21     ### The following return a distribution over values (for classification)
22     def empirical(data, domain=[0,1], icount=0):
23         "empirical dist "
24         # returns a distribution over values
25         # icount is pseudo count for each value
26         counts = {v:icount for v in domain}
27         for e in data:
28             counts[e] += 1
29         s = sum(counts.values())
30         return {k:v/s for (k,v) in counts.items()}
31
32     def laplace(data, domain=[0,1]):
33         "Laplace " # for categorical data
34         return Predict.empirical(data, domain, icount=1)
35
36     def cmode(data, domain=[0,1]):
37         "mode " # for categorical data
38         md = statistics.mode(data)
39         return {v: 1 if v==md else 0 for v in domain}
40
41     def cmedian(data, domain=[0,1]):
42         "median " # for categorical data
43         md = statistics.median_low(data) # always return one of the values
44         return {v: 1 if v==md else 0 for v in domain}
45
46     ### The following return a single prediction (for regression).
47     ### The domain argument is ignored.
48
49     def mean(data, domain=[0,1]):
50         "mean "
51         # returns a real number
52         return statistics.mean(data)
53
54     def rmean(data, domain=[0,1], mean0=0, pseudo_count=1):
55         "regularized mean"

```

```

56     # returns a real number.
57     # mean0 is the mean to be used for 0 data points
58     # With mean0=0.5, pseudo_count=2, same as laplace for [0,1] data
59     sm = mean0 * pseudo_count
60     count = pseudo_count
61     for e in data:
62         sm += e
63         count += 1
64     return sm/count
65
66     def mode(data, domain=[0,1]):
67         "mode"
68         return statistics.mode(data)
69
70     def median(data, domain=[0,1]):
71         "median"
72         return statistics.median(data)
73
74     all = [empirical, mean, rmean, laplace, cmode, mode, median, cmedian]
75
76     # The following suggests appropriate predictions as a function of the
77     # target type
78     select = {"boolean": [empirical, laplace, cmode, cmedian],
79             "categorical": [empirical, laplace, cmode, cmedian],
80             "numeric": [mean, rmean, mode, median]}

```

Exercise 7.4 Create a predictor `bounded_empirical` which is like `empirical` but avoids predictions of 0 or 1 (which can give errors for log loss), by using using some ϵ instead of 0 and $1 - \epsilon$ instead of 1, and otherwise uses the empirical mean.

The naive learner is a Learner that makes the same prediction for each example based just on the values of the training targets (not their inputs)

```

learnNoInputs.py — (continued)
81 from learnProblem import Learner #, Data_set
82
83 class Naive_learner(Learner):
84     def __init__(self, dataset, predictor=Predict.mean, **predictor_args):
85         """returns a predictor that makes the same prediction for every
86         example"""
87         self.dataset = dataset
88         self.predicted_value = predictor([dataset.target(e) for e in
89         dataset.train], **predictor_args)
90     def pred(e):
91         return self.predicted_value
92     pred.__doc__ = f"predict {self.predicted_value} for each value"
93     self.predictor = pred
94
95     def learn(self):
96         return self.predictor

```

```

96 |     def __str__(self):
97 |         return f"predict {self.predicted_value} for each value"

```

7.3.1 Evaluation

To evaluate a point prediction, let's first generate some possible values, 0 and 1 for the target feature. Given the ground truth *prob*, a number in the range $[0, 1]$, the following code generates some training and test data where *prob* is the probability of each example being 1. To generate a 1 with probability *prob*, it generates a random number in range $[0, 1]$ and return 1 if that number is less than *prob*. A prediction is computed by applying the predictor to the training data, which is evaluated on the test set. This is repeated *num_samples* times.

Let's evaluate the predictions of the possible selections according to the different evaluation criteria, for various training sizes.

```

learnNoInputs.py — (continued)
99 | def test_no_inputs(error_measures = Evaluate.all_criteria,
100 |                  num_samples=10000,
101 |                  test_size=10, training_sizes=
102 |                  [1,2,3,4,5,10,20,100,1000]):
103 |     for train_size in training_sizes:
104 |         results = {predictor: {error_measure: 0 for error_measure in
105 |                             error_measures}
106 |                   for predictor in Predict.all}
107 |         for sample in range(num_samples):
108 |             prob = random.random()
109 |             training = [1 if random.random()<prob else 0 for i in
110 |                       range(train_size)]
111 |             test = [1 if random.random()<prob else 0 for i in
112 |                    range(test_size)]
113 |             for predictor in Predict.all:
114 |                 prediction = predictor(training)
115 |                 for error_measure in error_measures:
116 |                     results[predictor][error_measure] += sum(
117 |                         error_measure(prediction, actual)
118 |                                     for actual in
119 |                                     test) /
120 |                                     test_size
121 |
122 |             print(f"For training size {train_size}:")
123 |             print("  Predictor\t", "\t".join(error_measure.__doc__ for
124 |                                             error_measure in
125 |                                             error_measures), sep="\t")
126 |
127 |             for predictor in Predict.all:
128 |                 print(f"  {predictor.__doc__}",
129 |                       "\t".join("{:.7f}".format(results[predictor][error_measure]/num_samples)
130 |                                 for error_measure in
131 |                                 error_measures), sep="\t")
132 |
133 | if __name__ == "__main__":

```

```
122 | test_no_inputs()
```

Exercise 7.5 Which predictor works best for low counts when the error is

- (a) Squared error
- (b) Absolute error
- (c) Log loss

You may need to try this a few times to make sure your answer is supported by the evidence. Does the difference from the other methods get more or less as the number of examples grow?

Exercise 7.6 Suggest other predictors that only take the training data. (E.g., `bounded_empirical` of Exercise 7.4, for some ϵ or to change the pseudo-counts of the Laplace method.)

7.4 Decision Tree Learning

To run the decision tree learning demo, in folder "aipython", load "learnDT.py", using e.g., `ipython -i learnDT.py`, and it prints some test results. To try more examples, copy and paste the commented-out commands at the bottom of that file. This requires Python 3 with `matplotlib`.

The decision tree algorithm does binary splits, and assumes that all input features are binary functions of the examples.

```
learnDT.py — Learning a binary decision tree
11 from learnProblem import Learner, Evaluate
12 from learnNoInputs import Predict
13 import math
14
15 class DT_learner(Learner):
16     def __init__(self,
17                 dataset,
18                 split_to_optimize=Evaluate.log_loss, # to minimize for at
19                 leaf_prediction=Predict.empirical, # what to use for value
20                 train=None, # used for cross validation
21                 max_num_cuts=8, # maximum number of conditions to split a
22                 gamma=1e-7, # minimum improvement needed to expand a node
23                 min_child_weight=10):
24         self.dataset = dataset
25         self.target = dataset.target
26         self.split_to_optimize = split_to_optimize
27         self.leaf_prediction = leaf_prediction
28         self.max_num_cuts = max_num_cuts
```

```

29     self.gamma = gamma
30     self.min_child_weight = min_child_weight
31     if train is None:
32         self.train = self.dataset.train
33     else:
34         self.train = train
35
36     def learn(self, max_num_cuts=8):
37         """learn a decision tree"""
38         self.predictor =
39             self.learn_tree(self.dataset.conditions(self.max_num_cuts),
40                             self.train)
41         return self.predictor
42
43     def __str__(self):
44         """string only exists after learning"""
45         return self.predictor.__doc__

```

The main recursive algorithm, takes in a set of input features and a set of training data. It first decides whether to split. If it doesn't split, it makes a point prediction, ignoring the input features.

It only splits if the best split increases the error by at least γ . This implies it does not split when:

- there are no more input features
- there are fewer examples than *min_number_examples*,
- all the examples agree on the value of the target, or
- the best split puts all examples in the same partition.

If it splits, it selects the best split according to the evaluation criterion (assuming that is the only split it gets to do), and returns the condition to split on (in the variable *split*) and the corresponding partition of the examples.

```

learnDT.py — (continued)
45     def learn_tree(self, conditions, data_subset):
46         """returns a decision tree
47         conditions is a set of possible conditions
48         data_subset is a subset of the data used to build this (sub)tree
49
50         where a decision tree is a function that takes an example and
51         makes a prediction on the target feature
52         """
53         self.display(2, f"learn_tree with {len(conditions)} features and
54                         {len(data_subset)} examples")
55         split, partn = self.select_split(conditions, data_subset)
56         if split is None: # no split; return a point prediction
57             prediction = self.leaf_value(data_subset, self.target.frange)

```

```

57         self.display(2, f"leaf prediction for {len(data_subset)}
58             examples is {prediction}")
59         def leaf_fun(e):
60             return prediction
61         leaf_fun.__doc__ = str(prediction)
62         leaf_fun.num_leaves = 1
63         return leaf_fun
64     else: # a split succeeded
65         false_examples, true_examples = partn
66         rem_features = [fe for fe in conditions if fe != split]
67         self.display(2, "Splitting on", split.__doc__, "with examples
68             split",
69                 len(true_examples), ":", len(false_examples))
70         true_tree = self.learn_tree(rem_features, true_examples)
71         false_tree = self.learn_tree(rem_features, false_examples)
72         def fun(e):
73             if split(e):
74                 return true_tree(e)
75             else:
76                 return false_tree(e)
77         #fun = lambda e: true_tree(e) if split(e) else false_tree(e)
78         fun.__doc__ = (f"(if {split.__doc__} then {true_tree.__doc__}"
79             f" else {false_tree.__doc__}")
80         fun.num_leaves = true_tree.num_leaves + false_tree.num_leaves
81         return fun

```

learnDT.py — (continued)

```

81     def leaf_value(self, egs, domain):
82         return self.leaf_prediction((self.target(e) for e in egs), domain)
83
84     def select_split(self, conditions, data_subset):
85         """finds best feature to split on.
86
87         conditions is a non-empty list of features.
88         returns feature, partition
89         where feature is an input feature with the smallest error as
90             judged by split_to_optimize or
91             feature==None if there are no splits that improve the error
92         partition is a pair (false_examples, true_examples) if feature is
93             not None
94         """
95         best_feat = None # best feature
96         # best_error = float("inf") # infinity - more than any error
97         best_error = self.sum_losses(data_subset) - self.gamma
98         self.display(3, " no split has
99             error=", best_error, "with", len(conditions), "conditions")
100        best_partition = None
101        for feat in conditions:
102            false_examples, true_examples = partition(data_subset, feat)
103            if

```

```

102         min(len(false_examples),len(true_examples))>=self.min_child_weight:
103         err = (self.sum_losses(false_examples)
104               + self.sum_losses(true_examples))
105         self.display(3," split on",feat.__doc__,"has error=",err,
106                    "splits
107                    into",len(true_examples),":",len(false_examples),"gamma=",self.gamma)
108         if err < best_error:
109             best_feat = feat
110             best_error=err
111             best_partition = false_examples, true_examples
112         self.display(2,"best split is on",best_feat.__doc__,
113                    "with err=",best_error)
114         return best_feat, best_partition
115
116     def sum_losses(self, data_subset):
117         """returns sum of losses for dataset (with no more splits)
118         There a single prediction for all leaves using leaf_prediction
119         It is evaluated using split_to_optimize
120         """
121         prediction = self.leaf_value(data_subset, self.target.frange)
122         error = sum(self.split_to_optimize(prediction, self.target(e))
123                    for e in data_subset)
124         return error
125
126     def partition(data_subset,feature):
127         """partitions the data_subset by the feature"""
128         true_examples = []
129         false_examples = []
130         for example in data_subset:
131             if feature(example):
132                 true_examples.append(example)
133             else:
134                 false_examples.append(example)
135         return false_examples, true_examples

```

Test cases:

```

learnDT.py — (continued)
136 from learnProblem import Data_set, Data_from_file
137
138 def testDT(data, print_tree=True, selections = None, **tree_args):
139     """Prints errors and the trees for various evaluation criteria and ways
140     to select leaves.
141     """
142     if selections == None: # use selections suitable for target type
143         selections = Predict.select[data.target.ftype]
144     evaluation_criteria = Evaluate.all_criteria
145     print("Split Choice", "Leaf Choice\t", "#leaves", '\t'.join(ecrit.__doc__
146                    for ecrit in
147                    evaluation_criteria), sep="\t")
148     for crit in evaluation_criteria:

```

```

147     for leaf in selections:
148         tree = DT_learner(data, split_to_optimize=crit,
149                           leaf_prediction=leaf,
150                               **tree_args).learn()
151         print(crit.__doc__, leaf.__doc__, tree.num_leaves,
152               "\t".join("{:.7f}").format(data.evaluate_dataset(data.test,
153                           tree, ecrit))
154               for ecrit in evaluation_criteria), sep="\t")
155
156     if print_tree:
157         print(tree.__doc__)
158
159 #DT_learner.max_display_level = 4 # more detailed trace
160 if __name__ == "__main__":
161     # Choose one of the data files
162     #data=Data_from_file('data/SPECT.csv', target_index=0);
163     print("SPECT.csv")
164     #data=Data_from_file('data/iris.data', target_index=-1);
165     print("iris.data")
166     data = Data_from_file('data/carbool.csv', one_hot=True,
167                           target_index=-1, seed=123)
168     #data = Data_from_file('data/mail_reading.csv', target_index=-1);
169     print("mail_reading.csv")
170     #data = Data_from_file('data/holiday.csv', has_header=True,
171                           num_train=19, target_index=-1); print("holiday.csv")
172     testDT(data, print_tree=False)

```

Note that different runs may provide different values as they split the training and test sets differently. So if you have a hypothesis about what works better, make sure it is true for different runs.

Exercise 7.7 The current algorithm does not have a very sophisticated stopping criterion. What is the current stopping criterion? (Hint: you need to look at both *learn_tree* and *select_split*.)

Exercise 7.8 Extend the current algorithm to include in the stopping criterion

- A minimum child size; don't use a split if one of the children has fewer elements than this.
- A depth-bound on the depth of the tree.
- An improvement bound such that a split is only carried out if error with the split is better than the error without the split by at least the improvement bound.

Which values for these parameters make the prediction errors on the test set the smallest? Try it on more than one dataset.

Exercise 7.9 Without any input features, it is often better to include a pseudo-count that is added to the counts from the training data. Modify the code so that it includes a pseudo-count for the predictions. When evaluating a split, including pseudo counts can make the split worse than no split. Does pruning with an improvement bound and pseudo-counts make the algorithm work better than with an improvement bound by itself?

Exercise 7.10 Some people have suggested using information gain (which is equivalent to greedy optimization of log loss) as the measure of improvement when building the tree, even in they want to have non-probabilistic predictions in the final tree. Does this work better than myopically choosing the split that is best for the evaluation criteria we will use to judge the final prediction?

7.5 *k*-fold Cross Validation and Parameter Tuning

To run the cross validation demo, in folder "aipython", load "learnCrossValidation.py", using e.g., `ipython -i learnCrossValidation.py`. The commented-out commands at the bottom can produce a graph like Figure 7.15. Different runs will produce different graphs, so your graph will be different the one in [Poole and Mackworth, 2023].

k-fold cross validation is more sophisticated than dividing the non-test set into a training and validation set as done above. If you are doing *k*-fold cross validation, set `prob_valid` to 0 in `Data`, as this does its own division into validation sets.

The above decision tree algorithm tends to overfit the data. One way to determine whether the prediction is overfitting is by cross validation. The code below implements *k*-fold cross validation, which can be used to choose the value of parameters to best fit the training data. If we want to use parameter tuning to improve predictions on a particular dataset, we can only use the training data (and not the test data) to tune the parameter.

k-fold cross validation partitions the training set into *k* approximately equal-sized folds. For each fold, it trains on the other examples, and determine the error of the prediction on that fold. For example, if there are 10 folds, it train on 90% of the data, and tests on remaining 10% of the data. It does this 10 times, so that each example gets used as a test set once, and in the training set 9 times.

The code below creates one copy of the data, and multiple views of the data. For each fold, *fold* enumerates the examples in the fold, and *fold_complement* enumerates the examples not in the fold.

```

learnCrossValidation.py — Cross Validation for Parameter Tuning
11 from learnProblem import Data_set, Data_from_file, Evaluate
12 from learnNoInputs import Predict
13 from learnDT import DT_learner
14 import matplotlib.pyplot as plt
15 import random
16
17 class K_fold_dataset(object):
18     def __init__(self, training_set, num_folds):
19         self.data = training_set.train.copy()

```

```

20     self.target = training_set.target
21     self.input_features = training_set.input_features
22     self.num_folds = num_folds
23     self.conditions = training_set.conditions
24
25     random.shuffle(self.data)
26     self.fold_boundaries = [(len(self.data)*i)//num_folds
27                             for i in range(0,num_folds+1)]
28
29     def fold(self, fold_num):
30         for i in range(self.fold_boundaries[fold_num],
31                       self.fold_boundaries[fold_num+1]):
32             yield self.data[i]
33
34     def fold_complement(self, fold_num):
35         for i in range(0,self.fold_boundaries[fold_num]):
36             yield self.data[i]
37         for i in range(self.fold_boundaries[fold_num+1],len(self.data)):
38             yield self.data[i]

```

The validation error is the average error for each example, where we test on each fold, and learn on the other folds.

```

_____learnCrossValidation.py — (continued)_____
40     def validation_error(self, learner, error_measure, **other_params):
41         error = 0
42         try:
43             for i in range(self.num_folds):
44                 predictor = learner(self,
45                                   train=list(self.fold_complement(i)),
46                                   **other_params).learn()
47                 error += sum( error_measure(predictor(e), self.target(e))
48                               for e in self.fold(i))
49         except ValueError:
50             return float("inf") #infinity
51         return error/len(self.data)

```

The `plot_error` method plots the average error as a function of the minimum number of examples in decision-tree search, both for the validation set and for the test set. The error on the validation set can be used to tune the parameter — choose the value of the parameter that minimizes the error. The error on the test set cannot be used to tune the parameters; if it were to be used this way it could not be used to test how well the method works on unseen examples.

```

_____learnCrossValidation.py — (continued)_____
52     def plot_error(data, criterion=Evaluate.squared_loss,
53                   leaf_prediction=Predict.empirical,
54                   num_folds=5, maxx=None, xscale='linear'):
55         """Plots the error on the validation set and the test set
56         with respect to settings of the minimum number of examples.

```

```

57 | xscale should be 'log' or 'linear'
58 | """
59 | plt.ion()
60 | fig, ax = plt.subplots()
61 | ax.set_xscale(xscale) # change between log and linear scale
62 | ax.set_xlabel("min_child_weight")
63 | ax.set_ylabel("average "+criterion.__doc__)
64 | folded_data = K_fold_dataset(data, num_folds)
65 | if maxx == None:
66 |     maxx = len(data.train)//2+1
67 | errors = [] # validation errors
68 | errors = [] # test set errors
69 | for mcw in range(1,maxx):
70 |     verrors.append(folded_data.validation_error(DT_learner, criterion,
71 |                                                 leaf_prediction=leaf_prediction,
72 |                                                 min_child_weight=mcw))
73 |     tree = DT_learner(data, criterion, leaf_prediction=leaf_prediction,
74 |                       min_child_weight=mcw).learn()
75 |     terrors.append(data.evaluate_dataset(data.test,tree,criterion))
76 | ax.plot(range(1,maxx), verrors, ls='-',color='k',
77 |        label="validation for "+criterion.__doc__)
78 | ax.plot(range(1,maxx), terrors, ls='--',color='k',
79 |        label="test set for "+criterion.__doc__)
80 | ax.legend()
81 |
82 | # The following produces variants of Figure 7.18 of Poole and Mackworth
83 | # [2023]
84 | # data = Data_from_file('data/SPECT.csv',target_index=0, prob_valid=0)
85 | # plot_error(data, criterion=Evaluate.log_loss,
86 | #            leaf_prediction=Predict.laplace)
87 | # alternatively try:
88 | # plot_error(data)
89 | # data = Data_from_file('data/carbool.csv', one_hot=True, target_index=-1,
90 | #                       seed=123)

```

Figure 7.2 shows the average squared loss in the validation and test sets as a function of the `min_child_weight` in the decision-tree learning algorithm the SPECT dataset. It was plotted with `plot_error(data)`. The assumption behind cross validation is that the parameter that minimizes the loss on the validation set, will be a good parameter for the test set.

If you rerun the `Data_from_file`, you will get the new test and training sets, and so the graph will change.

Exercise 7.11 Change the error plot so that it can evaluate the stopping criteria of the exercise of Section 7.7. Which criteria makes the most difference?

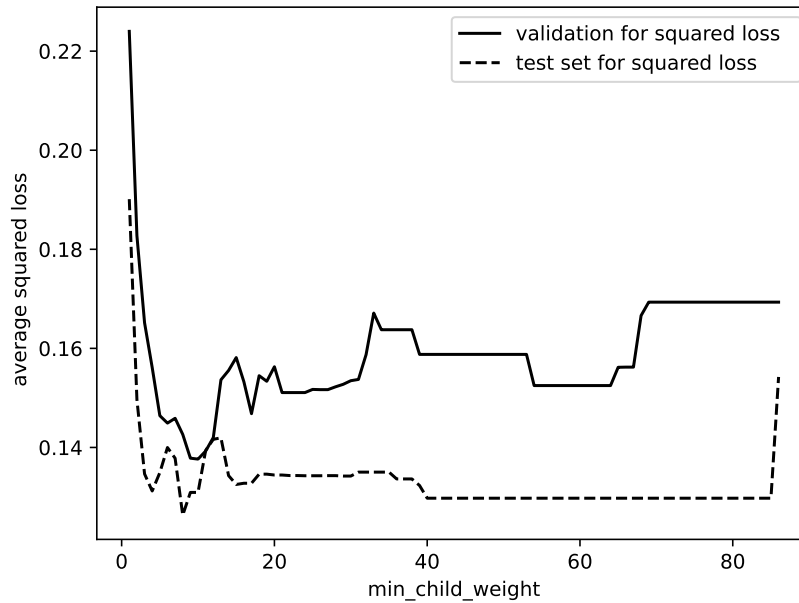

Figure 7.2: plot_error for SPECT dataset

7.6 Linear Regression and Classification

Here is a stochastic gradient descent searcher for linear regression and classification.

```

learnLinear.py — Linear Regression and Classification
11 from learnProblem import Learner
12 import random, math
13
14 class Linear_learner(Learner):
15     def __init__(self, dataset, train=None,
16                 learning_rate=0.01, max_init = 0, squashed=True,
17                 bias0=None):
18         """Creates a gradient descent searcher for a linear classifier.
19         The main learning is carried out by learn()
20
21         dataset provides the target and the input features
22         train provides a subset of the training data to use
23         learning_rate is the gradient descent step size
24         max_init is the maximum absolute value of the initial weights (does
25         this matter?)
26         squashed specifies whether the output is a squashed linear function
27         bias0 is initial bias if not None
28         """

```

```

27     self.dataset = dataset
28     self.target = dataset.target
29     if train==None:
30         self.train = self.dataset.train
31     else:
32         self.train = train
33     self.learning_rate = learning_rate
34     self.squashed = squashed
35     self.input_features = [one]+dataset.input_features # one is defined
        below
36     self.weights = {feat:random.uniform(-max_init,max_init)
37                     for feat in self.input_features}
38     if bias0 is not None:
39         self.weights[one] = bias0

```

predictor predicts the value of an example from the current parameter settings.

```

learnLinear.py — (continued)
41
42     def predictor(self,e):
43         """returns the prediction of the learner on example e"""
44         linpred = sum(w*f(e) for f,w in self.weights.items())
45         if self.squashed:
46             return sigmoid(linpred)
47         else:
48             return linpred
49
50     def __str__(self, sig_dig=3):
51         """returns the doc string for the current prediction function
52         sig_dig is the number of significant digits in the numbers"""
53         doc = "+".join(str(round(val,sig_dig))+"*"+feat.__doc__
54                         for feat,val in self.weights.items())
55         if self.squashed:
56             return "sigmoid("+ doc+")"
57         else:
58             return doc

```

learn is the main algorithm of the learner. It does num_iter steps (batches) of stochastic gradient descent, for the given batch size.

```

learnLinear.py — (continued)
60     def learn(self, batch_size=32, num_iter=1000):
61         batch_size = min(batch_size, len(self.train))
62         d = {feat:0 for feat in self.weights}
63         for it in range(num_iter):
64             self.display(2,f"prediction= {self}")
65             for e in random.sample(self.train, batch_size):
66                 error = self.predictor(e) - self.target(e)
67                 for feat in self.weights:
68                     d[feat] += error*feat(e)

```

```

69         for feat in self.weights:
70             self.weights[feat] -= self.learning_rate*d[feat]
71             d[feat]=0
72     return self.predictor

```

one is a function that always returns 1. This is used for one of the input properties.

```

-----learnLinear.py --- (continued)-----
74 def one(e):
75     "1"
76     return 1

```

sigmoid(x) is the function

$$\frac{1}{1 + e^{-x}}$$

The inverse of *sigmoid* is the *logit* function

```

-----learnLinear.py --- (continued)-----
78 def sigmoid(x):
79     return 1/(1+math.exp(-x))
80
81 def logit(x):
82     return -math.log(1/x-1)

```

softmax($[x_0, x_2, \dots]$) returns $[v_0, v_2, \dots]$ where

$$v_i = \frac{\exp(x_i)}{\sum_j \exp(x_j)}$$

```

-----learnLinear.py --- (continued)-----
84 def softmax(xs, domain=None):
85     """xs is a list of values, and
86     domain is the domain (a list) or None if the list should be returned
87     returns a distribution over the domain (a dict)
88     """
89     m = max(xs) # use of m prevents overflow (and all values underflowing)
90     exps = [math.exp(x-m) for x in xs]
91     s = sum(exps)
92     if domain:
93         return {d:v/s for (d,v) in zip(domain,exps)}
94     else:
95         return [v/s for v in exps]
96
97 def indicator(v, domain):
98     return [1 if v==dv else 0 for dv in domain]

```

The following tests the learner on a datasets. Uncomment another dataset for different examples.

```

learnLinear.py — (continued)
100 from learnProblem import Data_set, Data_from_file, Evaluate
101 from learnProblem import Evaluate
102 import matplotlib.pyplot as plt
103
104 if __name__ == "__main__":
105     data = Data_from_file('data/SPECT.csv', target_index=0)
106     # data = Data_from_file('data/mail_reading.csv', target_index=-1)
107     # data = Data_from_file('data/carbool.csv', one_hot=True,
108                             target_index=-1)
109     ll = Linear_learner(data)
110     ll.learn()
111     ll.evaluate()

```

The following plots the errors on the training and validation sets as a function of the number of steps of gradient descent.

```

learnLinear.py — (continued)
112 def plot_steps(data,
113               learner=None,
114               criterion=Evaluate.squared_loss,
115               step=1,
116               num_steps=1000,
117               log_scale=True,
118               legend_label=""):
119     """
120     plots the training and validation error for a learner.
121     data is the dataset
122     learner is the learning algorithm (default is linear learner on the
123         data)
124     criterion gives the evaluation criterion plotted on the y-axis
125     step specifies how many steps are run for each point on the plot
126     num_steps is the number of points to plot
127     """
128     if legend_label != "": legend_label+=" "
129     plt.ion()
130     fig, ax = plt.subplots()
131     ax.set_xlabel("step")
132     ax.set_ylabel("Average "+criterion.__doc__)
133     if log_scale:
134         ax.set_xscale('log') #plt.semilogx() #Makes a log scale
135     else:
136         ax.set_xscale('linear')
137     if learner is None:
138         learner = Linear_learner(data)
139     train_errors = []
140     valid_errors = []
141     for i in range(1,num_steps+1,step):
142         valid_errors.append(data.evaluate_dataset(data.valid,
143                                                  learner.predictor, criterion))

```

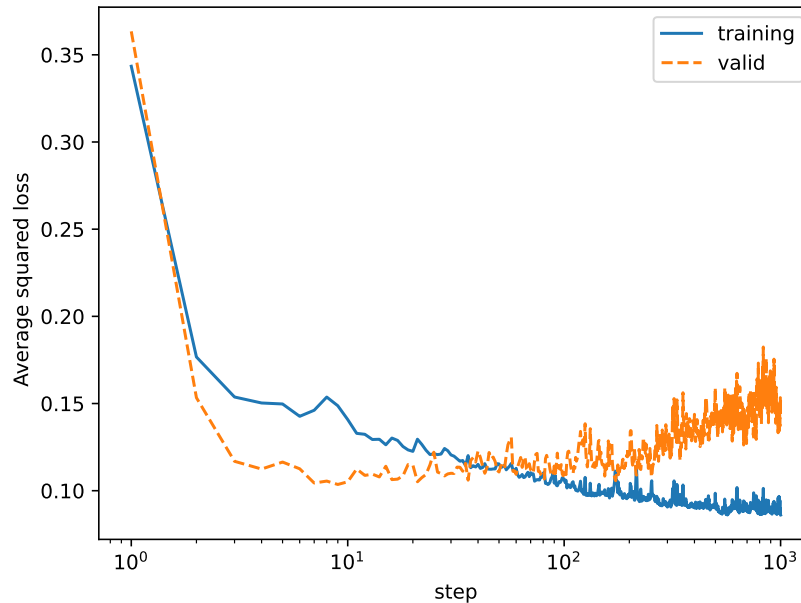

Figure 7.3: plot_steps for SPECT dataset

```

143     train_errors.append(data.evaluate_dataset(data.train,
144     learner.predictor, criterion))
145     learner.display(2, "Train error:", train_errors[-1],
146     "Valid error:", valid_errors[-1])
147     learner.learn(num_iter=step)
148     ax.plot(range(1, num_steps+1, step), train_errors, ls='-', label=legend_label+"training")
149     ax.plot(range(1, num_steps+1, step), valid_errors, ls='--', label=legend_label+"validation")
150     ax.legend()
151     #plt.draw()
152     learner.display(1, "Train error:", train_errors[-1],
153     "Validation error:", valid_errors[-1])
154 # This generates the figure
155 # from learnProblem import Data_set_augmented, prod_feat
156 # data = Data_from_file('data/SPECT.csv', prob_valid=0.5, target_index=0,
157 # seed=123)
158 # dataplus = Data_set_augmented(data, [], [prod_feat])
159 # plot_steps(data, num_steps=1000)
160 # plot_steps(dataplus, num_steps=1000) # warning slow

```

Figure 7.3 shows the result of `plot_steps(data, num_steps=1000)` in the code above. What would you expect to happen with the augmented data (with extra features)? Hint: think about underfitting and overfitting.

Exercise 7.12 In Figure 7.3, the log loss is very unstable when there are over 20

steps. Hypothesize why this occurs. [Hint: when does gradient descent become unstable?] Test your hypothesis by running with different hyperparameters.

Exercise 7.13 The squashed learner only makes predictions in the range $(0, 1)$. If the output values are $\{1, 2, 3, 4\}$ there is no use predicting less than 1 or greater than 4. Change the squashed learner so that it can learn values in the range $(1, 4)$. Test it on the file 'data/car.csv'.

The following plots the prediction as a function of the number of steps of gradient descent. We first define a version of *range* that allows for real numbers (integers and floats). This is similar to `numpy.arange`.

```

learnLinear.py — (continued)
161 def arange(start, stop, step):
162     """enumerates values in the range [start, stop) separated by step.
163     like range(start, stop, step) but allows for integers and floats.
164     Rounding errors are expected with real numbers. (or use numpy.arange)
165     """
166     while start < stop:
167         yield start
168         start += step
169
170 def plot_prediction(data,
171                   learner = None,
172                   minx = 0,
173                   maxx = 5,
174                   step_size = 0.01, # for plotting
175                   label = "function"):
176     plt.ion()
177     fig, ax = plt.subplots()
178     ax.set_xlabel("x")
179     ax.set_ylabel("y")
180     if learner is None:
181         learner = Linear_learner(data, squashed=False)
182     learner.learning_rate=0.001
183     learner.learn(num_iter=100)
184     learner.learning_rate=0.0001
185     learner.learn(num_iter=1000)
186     learner.learning_rate=0.00001
187     learner.learn(num_iter=10000)
188     learner.display(1, f"function learned is {learner}. "
189                   "error=", data.evaluate_dataset(data.train, learner.predictor,
190                   Evaluate.squared_loss))
191     ax.plot([e[0] for e in data.train], [e[-1] for e in
192         data.train], "bo", label="data")
193     ax.plot(list(arange(minx, maxx, step_size)),
194             [learner.predictor([x])
195             for x in arange(minx, maxx, step_size)],
196             label=label)
197     ax.legend(loc='upper left')

```

```

learnLinear.py -- (continued)
197 from learnProblem import Data_set_augmented, power_feat
198 def plot_polynomials(data,
199     learner_class = Linear_learner,
200     max_degree = 5,
201     minx = 0,
202     maxx = 5,
203     num_iter = 1000000,
204     learning_rate = 0.00001,
205     step_size = 0.01, # for plotting
206 ):
207     plt.ion()
208     fig, ax = plt.subplots()
209     ax.set_xlabel("x")
210     ax.set_ylabel("y")
211     ax.plot([e[0] for e in data.train],[e[-1] for e in
212         data.train],"ko",label="data")
213     x_values = list(arange(minx,maxx,step_size))
214     line_styles = ['-','--','-.-',':']
215     colors = ['0.5','k','k','k','k']
216     for degree in range(max_degree):
217         data_aug = Data_set_augmented(data,[power_feat(n) for n in
218             range(1,degree+1)],
219             include_orig=False)
220         learner = learner_class(data_aug,squashed=False)
221         learner.learning_rate = learning_rate
222         learner.learn(num_iter=num_iter)
223         learner.display(1,f"For degree {degree}, "
224             f"function learned is {learner}. "
225             "error=",data.evaluate_dataset(data.train,
226                 learner.predictor, Evaluate.squared_loss))
227         ls = line_styles[degree % len(line_styles)]
228         col = colors[degree % len(colors)]
229         ax.plot(x_values,[learner.predictor([x]) for x in x_values],
230             linestyle=ls, color=col,
231             label="degree="+str(degree))
232     ax.legend(loc='upper left')
233
234 # Try:
235 # data0 = Data_from_file('data/simp_regr.csv', prob_test=0, prob_valid=0,
236     one_hot=False, target_index=-1)
237 # plot_prediction(data0)
238 # Alternatively:
239 # plot_polynomials(data0)
240 # What if the step size was bigger?
241 #datam = Data_from_file('data/mail_reading.csv', target_index=-1)
242 #plot_prediction(datam)

```

Exercise 7.14 For each of the polynomial functions learned: What is the prediction as x gets larger ($x \rightarrow \infty$). What is the prediction as x gets more negative

$(x \rightarrow -\infty)$.

7.6.1 Rating Data

Much real-world data does not come in the terms of tables where there is a case for each tuple and one of the columns is a feature to be learned as a function of the other columns. Data typically has to be transformed into such a format. The example we will use data where there is a person-item-rating-timestamp table and an item-properties table.

MovieLens¹ is non-commercial, personalized movie recommendation system, for which a number of datasets are publicly available. The items in are movies and the properties are genres of movies. The aim is to predict the rating of a movie for a user.

These are easy to understand datasets, where students may have even watched some of the movies. This domain is pedagogically interesting because there are multiple learning possibilities. Let's predict the future from the past; ratings before a timestamp are used for training and those after are used for testing. (This is a more reasonable test of a real application than choosing random splits.) You can learn global predictions (using all of the ratings) or treat each user as a dataset. It is challenging for a number of reasons: The number of training ratings per user ranges from zero to hundreds. The ratings are not selected at random; most people only watch movies they think they might like. Many people do not rate movies of all genres; for example, most people have not rated horror movies, and thus it is difficult to predict whether they will like horror movies. Similar issues arise in many practical datasets.

There are 18 genres for movies, including *action*, *adventure*, *animation*, *children*, *comedy*, and *crime*. Each movie can have multiple genres. For example, Toy Story (1995) has genres *animation*, *children*, *comedy*. The rating is an integer from 1 to 5.

In the Movielens dataset(s), all users had rated at least 20 movies. We have split the rating by time: movies on or before the given timestamp are in the training set, those after are in the test set. (Different datasets are obtained by changing the timestamp; it is even possible to consider predicting the future from the past for all timestamps.) This means that some users have few (or no) movies in the training set. This is more representative of a real application

¹Movielens [Harper and Konstan, 2015] is a research project by the GroupLens research group at the University of Minnesota. Datasets of various sizes are available from <https://www.grouplens.org/datasets/movielens/>. To make this accessible to the most students, we used the smallest datasets. The small latest Movielens dataset does not have many users that span a timestamp (have ratings before and after the time) for any of the timestamps we tried, which is why it was not used. Newer datasets have a different format for the movie files. The newer datasets are in csv format, which makes them more standard, so use the Python csv package to read (as many titles contain commas). The newer datasets also contain fractional ratings, such as 3.5 or 0.5, which breaks the code here. If the larger datasets are too big and you want to test extrapolation (predicting the future from the past), we suggest you select the ratings between two timestamps, rather than selecting random users.

where many people have few ratings – indeed everyone starts with few ratings, and presumably they need recommendations to keep them on the system.

The following assumes that the older 100k dataset is downloaded from <https://grouplens.org/datasets/movielens/>. Unzip ml-100k.zip into the current directory.

```

learnRatings.py — Rating data for linear learner
11 import matplotlib.pyplot as plt
12 import urllib.request
13 import csv
14 from statistics import mean
15 from display import Displayable
16 from learnProblem import Data_set, Learner, Evaluate
17 from learnNoInputs import Naive_learner
18 from learnLinear import Linear_learner
19
20 class Data_set_from_ratings(Data_set):
21     def __init__(self,
22                 time_split=891382267, # 90% training
23                 #time_split=888259984, # 75% training
24                 #time_split=880845177, # 60% training
25                 #time_split=882826944, # halfway split
26                 ratings_file_name="ml-100k/u.data",
27                 item_file_name="ml-100k/u.item",
28                 genres_start=5,
29                 ratings_separator = '\t',
30                 movie_separator="|"):
31         """
32         ratings before time_split are training set. Those after are test.
33         genres_start is starting position of genres in item file
34
35         This code assumes that the older 100k dataset is downloaded from
36         https://grouplens.org/datasets/movielens/
37         Unzip ml-100k.zip into the current directory.
38         """
39         self.genres = ["Action", "Adventure", "Animation", "Children",
40                      "Comedy", "Crime", "Documentary", "Drama", "Fantasy",
41                      "Film-Noir", "Horror", "Musical", "Mystery",
42                      "Romance", "Sci-Fi", "Thriller", "War", "Western"]
43         genre2pos = {genre:pos for (pos,genre) in enumerate(self.genres)}
44         self.users = set() #set of users
45
46
47         self.display(1,"Movie Rating Dataset. Reading...")
48         with open(ratings_file_name,'r') as ratings_file:
49             #all_ratings = csv.reader(ratings_file,
50                                     delimiter=ratings_separator)
51             all_ratings = (line.strip().split(ratings_separator) for line

```

```

52     # Get rating information:
53     self.training_data = []
54     self.test_data = []
55     self.timestamps = []
56     self.training_stats = {1:0, 2:0, 3:0, 4:0 ,5:0}
57     self.test_stats = {1:0, 2:0, 3:0, 4:0 ,5:0}
58     for quadruple in all_ratings:
59         (user,item,rating,timestamp) = tuple(int(v) for v in
60             quadruple)
61         self.timestamps.append(timestamp) # useful for picking split
62         self.users.add(user)
63         if timestamp <= time_split:
64             self.training_data.append((user,item,rating))
65             self.training_stats[rating] += 1
66         else:
67             self.test_data.append((user,item,rating))
68             self.test_stats[rating] += 1
69     self.training_mean = (sum(r*n for (r,n) in
70         self.training_stats.items())
71         /sum(self.training_stats.values()))
72
73     # Get movie information:
74     with open(item_file_name,'r', encoding='ISO-8859-1') as item_file:
75         self.item_titles = {}
76         self.item_props = {}
77         self.extra_genres = {}
78         item_lines = (line.strip().split(movie_separator) for line in
79             item_file)
80         #item_lines = csv.reader(item_file, delimiter=movie_separator)
81         for items in item_lines:
82             movieId = int(items[0])
83             self.item_titles[movieId] = items[1]
84             self.item_props[movieId] = [int(v) for v in
85                 items[genres_start:]]
86
87     # the following is to create pseudo examples (see text)
88     self.item_props[-1] = [1 for _ in self.genres] # special movie
89     self.item_props[-2] = [0 for _ in self.genres]
90
91     Data_set.__init__(self, self.training_data,
92         test=self.test_data, prob_valid=0,
93         target_index=2, header=self.genres,
94         target_type="numeric")
95
96     # Create input features:
97     # input features are properties of the item (e[1]) for rating e
98     self.input_features = []
99     for i in range(len(self.header)):
100         def feat(e, ind=i):
101             return self.item_props[e[1]][ind]
102         feat.type = "boolean"

```

```

96         feat.__doc__ = self.header[i]
97         self.input_features.append(feat)
98         self.show_stats()
99
100     def show_stats(self):
101         self.display(1, len(self.training_data), "training ratings and",
102                     len(self.test_data), "test ratings")
103         self.tr_users = {user for (user, item, rating) in self.training_data}
104         self.test_users = {user for (user, item, rating) in self.test_data}
105         self.display(1, "users:", len(self.tr_users), "training,", len(self.test_users), "test,",
106                     len(self.tr_users & self.test_users), "in common")
107         tr_items = {item for (user, item, rating) in self.training_data}
108         test_items = {item for (user, item, rating) in self.test_data}
109         self.display(1, "items:", len(tr_items), "training,", len(test_items), "test,",
110                     len(tr_items & test_items), "in common")
111         self.display(1, "Rating statistics for training set:
112                     ", self.training_stats)
113         self.display(1, "Mean training rating: ", self.training_mean)
114         self.display(1, "Rating statistics for test set: ", self.test_stats)
115
116     def test():
117         global movielens, naive_learner, naive_predictor, global_learner,
118             global_predictor
119         movielens = Data_set_from_ratings()
120         naive_learner = Naive_learner(movielens)
121         naive_predictor = naive_learner.learn()
122         naive_learner.evaluate()
123         global_learner = Linear_learner(movielens, learning_rate = 0.001,
124             squashed=False)
125         global_predictor = global_learner.learn(num_iter=10000)
126         global_learner.evaluate()
127
128     if __name__ == "__main__":
129         test()

```

Exercise 7.15 How does the code need to change if the aim is predict whether a person likes a movie, where *likes* means “rating is greater than 3”, evaluated by log loss?

Exercise 7.16 Look at the weights for the learned linear function. Do negative weights for *Comedy* and positive weights for *Horror* imply that people generally don’t like comedy and like horror movies? (Hint: think about who rates the movies. Also consider how genre(s) may be correlated. Depending on the split, the weights may not be like that.)

The preceding code gave global predictions: the same rating for a movie was given for each user. The following code creates a dataset for each user. There are as many datasets as there are users. This only constructs datasets for users with both training and test ratings. The `Linear_learner` is hard coded into this to make the code simpler.

learnRatings.py — (continued)

```

128 class UserDataSets(Displayable):
129     def __init__(self, ratings):
130         """ ratings is a Data_set_from_ratings
131         """
132         self.ratings = ratings
133
134     def create_user_datatsets(self, pseudo):
135         """
136         create a dataset for each user.
137         pseudo is the number of each of the pseudo examples added (see code
138         document)
139         """
140         self.pseudo = pseudo
141         self.user2train = {} # user to list of training examples dict
142         self.user2test = {} # user to list of test examples dict
143         self.pseudo_egs = [(-1,-1,self.ratings.training_mean),
144                             (-1,-2,self.ratings.training_mean)]* pseudo
145         for (user,item,rating) in self.ratings.train:
146             if user not in self.user2train:
147                 self.user2train[user] = self.pseudo_egs.copy()
148                 self.user2train[user].append((user,item,rating))
149             for (user,item,rating) in self.ratings.test:
150                 if user in self.user2test:
151                     self.user2test[user].append((user,item,rating))
152                 else:
153                     self.user2test[user] = [(user,item,rating)]
154         self.user2dataset = {}
155         for user in self.user2test:
156             if user in self.user2train:
157                 self.user2dataset[user] = A_users_ratings(self.ratings,
158                                                             self.user2train[user], self.user2test[user])
159             return self.user2dataset
160
161     def learn_personalized(self, pseudo=0, ecrit=Evaluate.squared_loss):
162         """
163         learn personalized ratings for each user.
164         this assumes that test() is run to create the naive_learner and
165         global_learner
166         """
167         self.create_user_datatsets(pseudo=pseudo)
168         self.learners = {}
169         x_values = []
170         pers_values = []
171         naive_values = []
172         global_values = []
173         self.display(1,"user \t#train \t#test \tnaive \tglobal \tpersonal")
174         total_num_train = 0
175         total_num_test = 0
176         for user in self.user2dataset:

```

```

174         num_train = len(self.user2dataset[user].train)-2*self.pseudo
175         total_num_train += num_train
176         if num_train == 0: #no training data
177             predictor = naive_predictor
178             self.learners[user] = naive_learner
179         else:
180             lnr = Linear_learner(self.user2dataset[user], max_init=0.1,
181                                 learning_rate = 0.001, squashed=False)
182             predictor = lnr.learn(num_iter=1000)
183             self.learners[user] = lnr
184         error =
185             self.user2dataset[user].evaluate_dataset(self.user2dataset[user].test,
186             predictor, ecrit)
187         x_values.append(num_train)
188         pers_values.append(error)
189         naive_error =
190             self.user2dataset[user].evaluate_dataset(self.user2dataset[user].test,
191             naive_predictor, ecrit)
192         naive_values.append(naive_error)
193         global_error =
194             self.user2dataset[user].evaluate_dataset(self.user2dataset[user].test,
195             global_predictor, ecrit)
196         global_values.append(global_error)
197         total_num_test += len(self.user2dataset[user].test)
198         self.display(1, f"{user}\t{num_train}\t{len(self.user2dataset[user].test)}\t"
199                     f"{naive_error:.5f}\t{global_error:.5f}\t{error:.5f}")
200         self.display(1, f"mean\t{total_num_train/len(self.user2dataset):.1f}\t"
201                     f"{total_num_test/len(self.user2dataset):.1f}\t{mean(naive_values):.5f}\t"
202                     f"{mean(global_values):.5f}\t{mean(pers_values):.5f}")
203         self.display(1, f"{pseudo}")
204         plt.ion()
205         fig, ax = plt.subplots()
206         # ax.set_xscale('log') # lets you visualize small training datasets
207         better
208         ax.set_xlabel("training size")
209         ax.set_ylabel(ecrit.__doc__)
210         ax.plot(x_values, pers_values, "o", label=f"personalized {pseudo}")
211         ax.plot(x_values, naive_values, "x", label="naive")
212         ax.plot(x_values, global_values, "+", label="global")
213         ax.legend()
214         plt.show()
215
216     class A_users_ratings(Data_set):
217         def __init__(self, ratings_dataset, training, test):
218             self.max_display_level = 0
219             Data_set.__init__(self, training, test=test, prob_valid=0,
220                             num_properties=ratings_dataset.num_properties,
221                             target_index=ratings_dataset.target_index)
222             self.input_features = ratings_dataset.input_features

```

```

219 | if __name__ == "__main__":
220 |     userdatasets = UserDataSets(movielens)
221 |     userdatasets.learn_personalized(pseudo=0)

```

For the following exercises, test whether your answers also hold for other data splits.

Exercise 7.17 The above computes the average error, averaged over users. It is also possible to give the average error averaged over ratings. Which is fairer? Does this change the results? Hint: consider users with few test cases.

Exercise 7.18 What can be done with users with no training ratings? (They are not included in the above code.) Should they act randomly? Or should they make predictions based on population-level statistics? What does the code predict for those with no training data? What is an alternative? Does it work better?

Exercise 7.19 How does the performance of the personalized prediction compared to the global predictions depend on the number of training examples? Look at the results, and suggest a hypothesis. Give evidence (data) to support and/or oppose your hypothesis.

Exercise 7.20 What happen with users with few (or even just 1) training data-points? (Hint: Think about both the genres of the movies rated and the genres that don't occur in the movies rated.) Does overfitting occur? Suggest what should happen.

Exercise 7.21 The above code allows the inclusion of pseudo-examples. There are two pseudo-movies (-1 and -2) one of which has all genres and one of which has none. The parameter `pseudo` specifies how many ratings of each movie to include, where the rating for these is the global average rating. Does having pseudo examples give better predictions? If so, what is the best value for `pseudo`?

Exercise 7.22 Assume that there are k pseudo instances of the pseudo examples for each batch. How are the parameters updated in each batch? (How do the pseudo examples affect the parameter update for the batch?) How does this update relate to L1 or L2 regularization?

7.7 Boosting

The following code implements functional gradient boosting for regression.

A Boosted dataset is created from a base dataset by subtracting the prediction of the offset function from each example. This does not save the new dataset, but generates it as needed. The extra space used is constant, independent on the size of the dataset.

```

_____learnBoosting.py — Functional Gradient Boosting_____
11 | from learnProblem import Data_set, Learner, Evaluate
12 | from learnNoInputs import Predict
13 | from learnLinear import sigmoid
14 | import statistics
15 | import random

```

```

16
17 class Boosted_dataset(Data_set):
18     def __init__(self, base_dataset, offset_fun, subsample=1.0):
19         """new dataset which is like base_dataset,
20         but offset_fun(e) is subtracted from the target of each example e
21         """
22         self.base_dataset = base_dataset
23         self.offset_fun = offset_fun
24         self.train =
25             random.sample(base_dataset.train, int(subsample*len(base_dataset.train)))
26         self.valid = base_dataset.valid
27         #Data_set.__init__(self, base_dataset.train, base_dataset.valid,
28         #                    base_dataset.prob_valid, base_dataset.target_index)
29
30     def create_features(self):
31         """creates new features - called at end of Data_set.init()
32         defines a new target
33         """
34         self.input_features = self.base_dataset.input_features
35         def newout(e):
36             return self.base_dataset.target(e) - self.offset_fun(e)
37         newout.frange = self.base_dataset.target.frange
38         newout.ftype = self.infer_type(newout.frange)
39         self.target = newout
40
41     def conditions(self, *args, colsample_bytree=0.5, **nargs):
42         conds = self.base_dataset.conditions(*args, **nargs)
43         return random.sample(conds, int(colsample_bytree*len(conds)))

```

A boosting learner takes in a dataset and a base learner, and returns a new predictor. The base learner, takes a dataset, and returns a Learner object.

learnBoosting.py — (continued)

```

44 class Boosting_learner(Learner):
45     def __init__(self, dataset, base_learner_class, subsample=0.8):
46         self.dataset = dataset
47         self.base_learner_class = base_learner_class
48         self.subsample = subsample
49         mean = sum(self.dataset.target(e)
50                 for e in self.dataset.train)/len(self.dataset.train)
51         self.predictor = lambda e:mean # function that returns mean for
52             each example
53         self.predictor.__doc__ = "lambda e:"+str(mean)
54         self.offsets = [self.predictor] # list of base learners
55         self.predictors = [self.predictor] # list of predictors
56         self.errors = [data.evaluate_dataset(data.valid, self.predictor,
57             Evaluate.squared_loss)]
58         self.display(1, "Mean validation set squared loss=", self.errors[0] )
59
60     def learn(self, num_ensembles=10):

```

```

60     """adds num_ensemble learners to the ensemble.
61     returns a new predictor.
62     """
63     for i in range(num_ensembles):
64         train_subset = Boosted_dataset(self.dataset, self.predictor,
65                                     subsample=self.subsample)
66         learner = self.base_learner_class(train_subset)
67         new_offset = learner.learn()
68         self.offsets.append(new_offset)
69         def new_pred(e, old_pred=self.predictor, off=new_offset):
70             return old_pred(e)+off(e)
71         self.predictor = new_pred
72         self.predictors.append(new_pred)
73         self.errors.append(data.evaluate_dataset(data.valid,
74         self.predictor, Evaluate.squared_loss))
75         self.display(1,f"Iteration {len(self.offsets)-1},treesize =
76         {new_offset.num_leaves}. mean squared
77         loss={self.errors[-1]}")
78     return self.predictor

```

For testing, *sp_DT_learner* returns a learner that predicts the mean at the leaves and is evaluated using squared loss. It can also take arguments to change the default arguments for the trees.

learnBoosting.py — (continued)

```

76 # Testing
77
78 from learnDT import DT_learner
79 from learnProblem import Data_set, Data_from_file
80
81 def sp_DT_learner(split_to_optimize=Evaluate.squared_loss,
82                  leaf_prediction=Predict.mean,**nargs):
83     """Creates a learner with different default arguments replaced by
84     **nargs
85     """
86     def new_learner(dataset):
87         return DT_learner(dataset,split_to_optimize=split_to_optimize,
88                            leaf_prediction=leaf_prediction, **nargs)
89     return new_learner
90
91 #data = Data_from_file('data/car.csv', target_index=-1) regression
92 #data = Data_from_file('data/SPECT.csv', target_index=0, seed=62) #123)
93 #data = Data_from_file('data/mail_reading.csv', target_index=-1)
94 #data = Data_from_file('data/holiday.csv', has_header=True, num_train=19,
95                        target_index=-1)
96 #learner10 = Boosting_learner(data,
97     sp_DT_learner(split_to_optimize=Evaluate.squared_loss,
98                  leaf_prediction=Predict.mean, min_child_weight=10))
99 #learner7 = Boosting_learner(data, sp_DT_learner(0.7))
100 #learner5 = Boosting_learner(data, sp_DT_learner(0.5))
101 #predictor9 =learner9.learn(10)

```

```

98 #for i in learner9.offsets: print(i.__doc__)
99 import matplotlib.pyplot as plt
100
101 def plot_boosting_trees(data, steps=10, mcws=[30,20,20,10], gammas=
    [100,200,300,500]):
102     # to reduce clutter uncomment one of following two lines
103     #mcws=[10]
104     #gammas=[200]
105     learners = [(mcw, gamma, Boosting_learner(data,
        sp_DT_learner(min_child_weight=mcw, gamma=gamma)))
106                 for gamma in gammas for mcw in mcws
107                 ]
108     plt.ion()
109     fig, ax = plt.subplots()
110     ax.set_xscale('linear') # change between log and linear scale
111     ax.set_xlabel("number of trees")
112     ax.set_ylabel("mean squared loss")
113     markers = (m+c for c in ['k','g','r','b','m','c','y'] for m in
        ['-','-','-',':'])
114     for (mcw, gamma, learner) in learners:
115         data.display(1, f"min_child_weight={mcw}, gamma={gamma}")
116         learner.learn(steps)
117         ax.plot(range(steps+1), learner.errors, next(markers),
118                 label=f"min_child_weight={mcw}, gamma={gamma}")
119     ax.legend()
120
121 # plot_boosting_trees(data,mcws=[20], gammas= [100,200,300,500])
122 # plot_boosting_trees(data,mcws=[30,20,20,10], gammas= [100])

```

Exercise 7.23 For a particular dataset, suggest good values for `min_child_weight` and `gamma`. How stable are these to different random choices that are made (e.g., in the training-validation split)? Try to explain why these are good settings.

7.7.1 Gradient Tree Boosting

The following implements gradient Boosted trees for classification. If you want to use this gradient tree boosting for a real problem, we recommend using **XGBoost** [Chen and Guestrin, 2016] or **LightGBM** [Ke, Meng, Finley, Wang, Chen, Ma, Ye, and Liu, 2017].

GTB_learner subclasses DT_learner. The method `learn_tree` is used unchanged. DT_learner assumes that the value at the leaf is the prediction of the leaf, thus `leaf_value` needs to be overridden. It also assumes that all nodes at a leaf have the same prediction, but in GTB the elements of a leaf can have different values, depending on the previous trees. Thus `sum_losses` also needs to be overridden.

learnBoosting.py — (continued)

```

124 class GTB_learner(DT_learner):

```

```

125     def __init__(self, dataset, number_trees, lambda_reg=1, gamma=0,
126                 **dtargs):
127         DT_learner.__init__(self, dataset,
128                             split_to_optimize=Evaluate.log_loss, **dtargs)
129         self.number_trees = number_trees
130         self.lambda_reg = lambda_reg
131         self.gamma = gamma
132         self.trees = []
133
134     def learn(self):
135         for i in range(self.number_trees):
136             tree =
137                 self.learn_tree(self.dataset.conditions(self.max_num_cuts),
138                                 self.train)
139             self.trees.append(tree)
140             self.display(1, f""Iteration {i} treesize = {tree.num_leaves}
141                          train logloss={
142                              self.dataset.evaluate_dataset(self.dataset.train,
143                                                              self.gtb_predictor, Evaluate.log_loss)
144                              } validation logloss={
145                              self.dataset.evaluate_dataset(self.dataset.valid,
146                                                            self.gtb_predictor, Evaluate.log_loss)}""")
147         return self.gtb_predictor
148
149     def gtb_predictor(self, example, extra=0):
150         """prediction for example,
151         extras is an extra contribution for this example being considered
152         """
153         return sigmoid(sum(t(example) for t in self.trees)+extra)
154
155     def leaf_value(self, egs, domain=[0,1]):
156         """value at the leaves for examples egs
157         domain argument is ignored"""
158         predActs = [(self.gtb_predictor(e),self.target(e)) for e in egs]
159         return sum(a-p for (p,a) in predActs) / (sum(p*(1-p) for (p,a) in
160                                                    predActs)+self.lambda_reg)
161
162     def sum_losses(self, data_subset):
163         """returns sum of losses for dataset (assuming a leaf is formed
164         with no more splits)
165         """
166         leaf_val = self.leaf_value(data_subset)
167         error = sum(Evaluate.log_loss(self.gtb_predictor(e,leaf_val),
168                                     self.target(e))
169                    for e in data_subset) + self.gamma
170         return error

```

Testing

learnBoosting.py — (continued)

```
163 | # data = Data_from_file('data/carbool.csv', one_hot=True, target_index=-1,  
    |     seed=123)  
164 | # gtb_learner = GTB_learner(data, 10)  
165 | # gtb_learner.learn()
```

Exercise 7.24 Find better hyperparameter settings than the default ones. Compare prediction error with other methods for Boolean datasets.

Neural Networks and Deep Learning

Warning: this is not meant to be an efficient implementation of deep learning. If you want to do serious machine learning on medium-sized or large data, we recommend Keras (<https://keras.io>) [Chollet, 2021] or PyTorch (<https://pytorch.org>), which are very efficient, particularly on GPUs. They are, however, black boxes. The AIPython neural network code should be seen like a car engine made of glass; you can see exactly how it works, even if it is not fast.

We have followed the naming conventions of Keras for the parameters: any parameters that are the same as in Keras have the same names.

8.1 Layers

A neural network is built from layers. In AIPython (unlike Keras and PyTorch), activation functions are treated as separate layers, which makes them more modular and the code more readable.

This provides a modular implementation of layers. Layers can easily be stacked in many configurations. A layer needs to implement a method to compute the output values from the inputs, a method to back-propagate the error, and a method update its parameters (if it has any) for a batch.

```
learnNN.py — Neural Network Learning
11 from display import Displayable
12 from learnProblem import Learner, Data_set, Data_from_file,
   Data_from_files, Evaluate
13 from learnLinear import sigmoid, one, softmax, indicator
14 import random, math, time
15
```

```

16 class Layer(Displayable):
17     def __init__(self, nn, num_inputs=None, num_outputs=None):
18         """Abstract layer class, must be overridden.
19         nn is the neural network this layer is part of
20         num_outputs is the number of outputs for this layer.
21         """
22         self.nn = nn
23         self.num_inputs = nn.num_outputs if num_inputs is None else
24             num_inputs # nn output is layer's input
25         if num_outputs:
26             self.num_outputs = num_outputs
27         else:
28             self.num_outputs = self.num_inputs # same as the inputs
29             self.outputs= [0]*self.num_outputs
30             self.input_errors = [0]*self.num_inputs
31             self.weights = []
32
33     def output_values(self, input_values, training=False):
34         """Return the outputs for this layer for the given input values.
35         input_values is a list (of length self.num_inputs) of the inputs
36         returns a list of length self.num_outputs.
37         It can act differently when training and when predicting.
38         """
39         raise NotImplementedError("output_values") # abstract method
40
41     def backprop(self, out_errors):
42         """Backpropagate the errors on the outputs
43         errors is a list of output errors (of length self.num_outputs).
44         Returns list of input errors (of length self.num_inputs).
45
46         This is only called after corresponding output_values(),
47         which should remember relevant information
48         """
49         raise NotImplementedError("backprop") # abstract method
50
51 class Optimizer(Displayable):
52     def update(self, layer):
53         """updates parameters after a batch.
54         """
55     pass

```

8.1.1 Linear Layer

A linear layer maintains an array of weights. `self.weights[i][o]` is the weight between input `i` and output `o`. The bias is treated implicitly as the last input, so the weight of the bias for output `o` is `self.weights[self.num_inputs][o]`.

The default initialization is the Glorot uniform initializer [Glorot and Bengio, 2010], which is the default in Keras. An alternative is to provide a limit, in which case the values are selected uniformly in the range $[-limit, limit]$. As

in Keras, AIPython treats initializes the bias of hidden layers to zero. The output layer is treated separately, with the weights all zero except for the bias for categorical outputs (see following exercise).

```

learnNN.py — (continued)
56 class Linear_complete_layer(Layer):
57     """a completely connected layer"""
58     def __init__(self, nn, num_outputs, limit=None, final_layer=False,
59                 num_inputs=None):
60         """A completely connected linear layer.
61         nn is a neural network that the inputs come from
62         num_outputs is the number of outputs
63         the random initialization of parameters is in range [-limit,limit]
64         """
65         Layer.__init__(self, nn, num_inputs=num_inputs,
66                        num_outputs=num_outputs)
67         if limit is None:
68             limit =math.sqrt(6/(self.num_inputs+self.num_outputs))
69         # self.weights[i][o] is the weight between input i and output o
70         if final_layer:
71             self.weights = [[0 if i < self.num_inputs
72                             or (nn.output_type != "categorical")
73                             else 1
74                             for o in range(self.num_outputs)]
75                             for i in range(self.num_inputs+1)]
76         else:
77             self.weights = [[random.uniform(-limit, limit)
78                             if i < self.num_inputs else 0
79                             for o in range(self.num_outputs)]
80                             for i in range(self.num_inputs+1)]
81         # self.weights[i][o] is the accumulated change for a batch.
82         self.delta = [[0 for o in range(self.num_outputs)]
83                       for i in range(self.num_inputs+1)]
84
85     def output_values(self, inputs, training=False):
86         """Returns the outputs for the input values.
87         It remembers the values for the backprop.
88         """
89         self.display(3,f"Linear layer inputs: {inputs}")
90         self.inputs = inputs
91         for out in range(self.num_outputs):
92             self.outputs[out] = (sum(self.weights[inp][out]*self.inputs[inp]
93                                     for inp in range(self.num_inputs))
94                                 + self.weights[self.num_inputs][out])
95         self.display(3,f"Linear layer inputs: {inputs}")
96         return self.outputs
97
98     def backprop(self, errors):
99         """Backpropagate errors, update weights, return input error.
100        errors is a list of size self.num_outputs

```

```

99     Returns errors for layer's inputs of size
100     """
101     self.display(3,f"Linear Backprop. input: {self.inputs} output
        errors: {errors}")
102     for out in range(self.num_outputs):
103         for inp in range(self.num_inputs):
104             self.input_errors[inp] = self.weights[inp][out] * errors[out]
105             self.delta[inp][out] += self.inputs[inp] * errors[out]
106             self.delta[self.num_inputs][out] += errors[out]
107     self.display(3,f"Linear layer backprop input errors:
        {self.input_errors}")
108     return self.input_errors

```

Exercise 8.1 The initialization for the output layer is naive. Suggest an alternative (hopefully better) initialization. Test it.

Exercise 8.2 What happens if the initialization of the hidden layer weights is also zero? Try it. Explain why you get the behavior observed.

8.1.2 ReLU Layer

The standard activation function for hidden nodes is the **ReLU**.

```

learnNN.py — (continued)
110 class ReLU_layer(Layer):
111     """Rectified linear unit (ReLU)  $f(z) = \max(0, z)$ .
112     The number of outputs is equal to the number of inputs.
113     """
114     def __init__(self, nn):
115         Layer.__init__(self, nn)
116
117
118     def output_values(self, input_values, training=False):
119         """Returns the outputs for the input values.
120         It remembers the input values for the backprop.
121         """
122         self.input_values = input_values
123         for i in range(self.num_inputs):
124             self.outputs[i] = max(0, input_values[i])
125         return self.outputs
126
127     def backprop(self, out_errors):
128         """Returns the derivative of the errors"""
129         for i in range(self.num_inputs):
130             self.input_errors[i] = out_errors[i] if self.input_values[i]>0
                else 0
131         return self.input_errors

```

8.1.3 Sigmoid Layer

One of the old standards for the activation function for hidden layers is the sigmoid. It is also used in LSTMs. It is included here to experiment with.

```

learnNN.py — (continued)
133 class Sigmoid_layer(Layer):
134     """Sigmoids of the inputs.
135     The number of outputs is equal to the number of inputs.
136     Each output is the sigmoid of its corresponding input.
137     """
138     def __init__(self, nn):
139         Layer.__init__(self, nn)
140
141     def output_values(self, input_values, training=False):
142         """Returns the outputs for the input values.
143         It remembers the output values for the backprop.
144         """
145         for i in range(self.num_inputs):
146             self.outputs[i] = sigmoid(out_errors[i])
147         return self.outputs
148
149     def backprop(self, errors):
150         """Returns the derivative of the errors"""
151         for i in range(self.num_inputs):
152             self.input_errors[i] =
153                 input_values[i]*out_errors[i]*(1-out_errors[i])
154         return self.input_errors

```

8.2 Feedforward Networks

```

learnNN.py — (continued)
155 class NN(Learner):
156     def __init__(self, dataset, batch_gen=None, optimizer=None,
157                 **hyperparms):
158         """Creates a neural network for a dataset
159         batch_gen is the algorithm used to generate batches (e.g., random,
160         streaming)
161         optimizer is the optimizer: default is SGD
162         hyperparms is the dictionary of hyperparameters for the optimizer
163         """
164         self.batch_gen = Batch_generator(dataset.train) if batch_gen is
165             None else batch_gen
166         self.dataset = dataset
167         self.optimizer = optimizer if optimizer else SGD
168         self.hyperparms = hyperparms
169         self.output_type = dataset.target.ftype
170         self.input_features = dataset.input_features

```

```

168     self.num_outputs = len(self.input_features) # empty NN
169     self.layers = []
170     self.bn = 0 # number of batches run
171     self.printed_heading = False # for tracing, so header printed once
172
173     def add_layer(self, layer):
174         """add a layer to the network.
175         Each layer gets number of inputs from the previous layers outputs.
176         """
177         self.layers.append(layer)
178         #if hasattr(layer, 'weights'):
179         layer.optimizer = self.optimizer(layer, **self.hyperparms)
180         self.num_outputs = layer.num_outputs
181
182     def predictor(self,ex):
183         """Predicts the value of the first output for example ex.
184         """
185         values = [f(ex) for f in self.input_features]
186         for layer in self.layers:
187             values = layer.output_values(values)
188         return sigmoid(values[0]) if self.output_type == "boolean" \
189             else softmax(values, self.dataset.target.frange) if
190             self.output_type == "categorical" \
191             else values[0]

```

The *learn* method learns the parameters of a network. This is like the `learn()` method of linear regression (Section 7.6) except that there can be multiple outputs and there can be multiple optimizers.

```

-----learnNN.py --- (continued) -----
192     def learn(self, batch_size=32, num_iter = 100, report_each=10):
193         """Learns parameters for a neural network using the chosen
194             optimizer.
195             batch_size is the size of each batch
196             num_iter is the number of iterations over the batches
197             report_each means print errors after each multiple of that number
198             of batches
199         """
200         self.report_each = report_each
201         if not self.printed_heading and num_iter >= report_each:
202             self.display(1,"batch\tTraining\tTraining\tValidation\tValidation")
203             self.display(1,"\tAccuracy\tLog loss\tAccuracy\tLog loss")
204             self.printed_heading = True
205             self.trace()
206         for i in range(num_iter):
207             batch = self.batch_gen.get_batch(batch_size)
208                 #random.sample(self.dataset.train, batch_size)
209             for e in batch:
210                 # compute all outputs
211                 values = [f(e) for f in self.input_features]
212                 for layer in self.layers:

```

```

210         values = layer.output_values(values, training=True)
211     # backpropagate
212     predicted = [sigmoid(v) for v in values] \
213                 if self.output_type == "boolean" \
214                 else softmax(values) \
215                 if self.output_type == "categorical" \
216                 else values
217     actuals = indicator(self.dataset.target(e),
218                        self.dataset.target.frange) \
219                if self.output_type == "categorical" \
220                else [self.dataset.target(e)]
221     errors = [pred-obsd for (obsd,pred) in
222              zip(actuals,predicted)]
223     for layer in reversed(self.layers):
224         errors = layer.backprop(errors)
225     # Update all parameters in batch
226     for layer in self.layers:
227         layer.optimizer.update(layer)
228     self.bn+=1
229     if (i+1)%report_each==0:
230         self.trace()
231
232     def trace(self):
233         """print tracing of the batch updates"""
234         self.display(1,self.bn,"\t",
235                     "\t\t".join("{:.4f}".format(
236                         self.dataset.evaluate_dataset(data, self.predictor,
237                                                         criterion))
238                                 for data in [self.dataset.train,
239                                               self.dataset.valid]
240                                 for criterion in [Evaluate.accuracy,
241                                                  Evaluate.log_loss]), sep="")

```

8.3 Optimizers

The optimizers update the weights of a layer after a batch; they implement update. The layer must have saved the weights. In layers without weights, the weights list is empty, and update does nothing. The backprop method stores in `layer.delta` the gradient for the most recent batch. An optimizer must zero `layer.delta` so the new batch can start anew.

8.3.1 Stochastic Gradient Descent

Stochastic Gradient Descent (SGD) is the most basic. It has one hyperparameter, the learning rate `lr`.

learnNN.py — (continued)

```

238 class Batch_generator(Displayable):
239     """Generator of batches.

```

```

240     Default implementation is to take a random subset of the dataset.
241     This may not be applicable for streaming data.
242     """
243     def __init__(self, dataset):
244         self.dataset = dataset
245
246     def get_batch(self, batch_size):
247         return random.sample(self.dataset, batch_size)
248
249 class SGD(Optimizer):
250     """Vanilla SGD"""
251     def __init__(self, layer, lr=0.01):
252         """layer is a layer, which contains weight and gradient matrices
253         Layers without weights have weights=[]
254         """
255         self.lr = lr
256
257     def update(self, layer):
258         """update weights of layer after a batch.
259         """
260         for inp in range(len(layer.weights)):
261             for out in range(len(layer.weights[0])):
262                 layer.weights[inp][out] -= self.lr*layer.delta[inp][out]
263                 layer.delta[inp][out] = 0

```

8.3.2 Momentum

```

learnNN.py — (continued)
265 class Momentum(Optimizer):
266     """SGD with momentum"""
267
268     """a completely connected layer"""
269     def __init__(self, layer, lr=0.01, momentum=0.9):
270         """
271         lr is the learning rate
272         momentum is the momentum parameter
273
274         """
275         self.lr = lr
276         self.momentum = momentum
277         layer.velocity = [[0 for _ in range((len(layer.weights[0])))]
278                          for _ in range(len(layer.weights))]
279
280
281     def update(self, layer):
282         """updates parameters after a batch with momentum"""
283         for inp in range(len(layer.weights)):
284             for out in range(len(layer.weights[0])):

```

```

285         layer.velocity[inp][out] =
            self.momentum*layer.velocity[inp][out] -
            self.lr*layer.delta[inp][out]
286         layer.weights[inp][out] += layer.velocity[inp][out]
287         layer.delta[inp][out] = 0

```

8.3.3 RMS-Prop

learnNN.py — (continued)

```

289 class RMS_Prop(Optimizer):
290     """a completely connected layer"""
291     def __init__(self, layer, rho=0.9, epsilon=1e-07, lr=0.01):
292         """A completely connected linear layer.
293         nn is a neural network that the inputs come from
294         num_outputs is the number of outputs
295         max_init is the maximum value for random initialization of
            parameters
296         """
297         # layer.ms[i][o] is running average of squared gradient input i and
            output o
298         layer.ms = [[0 for _ in range(len(layer.weights[0]))]
299                    for _ in range(len(layer.weights))]
300         self.rho = rho
301         self.epsilon = epsilon
302         self.lr = lr
303
304     def update(self, layer):
305         """updates parameters after a batch"""
306         for inp in range(len(layer.weights)):
307             for out in range(len(layer.weights[0])):
308                 layer.ms[inp][out] = self.rho*layer.ms[inp][out]+
                    (1-self.rho) * layer.delta[inp][out]**2
309                 layer.weights[inp][out] -= self.lr * layer.delta[inp][out] /
                    (layer.ms[inp][out]+self.epsilon)**0.5
310                 layer.delta[inp][out] = 0

```

Exercise 8.3 Implement Adam [see Section 8.2.3 of Poole and Mackworth, 2023]. The implementation is slightly more complex than RMS-Prop. Try it first with the parameter settings of Keras, as reported by Poole and Mackworth [2023]. Does it matter if epsilon is inside or outside the square root? How sensitive is the performance to the parameter settings?

Exercise 8.4 Both Goodfellow, Bengio, and Courville [2016] and Poole and Mackworth [2023] find the gradient by dividing `self.delta[inp][out]` by the batch size, but some of the above code doesn't. To make code with dividing and without dividing the same, the step sizes need to be different by a factor of the batch size. Find a reasonable step size using an informal hyperparameter tuning; try some orders of magnitude of the step size to see what works best. What happens if the batch size is changed, but the step size is unchanged? (Try orders of magnitude difference is step sizes.) For each of the update method, which works better: dividing by the step size or not?

8.4 Dropout

Dropout is implemented as a layer.

```

learnNN.py — (continued)
312 from utilities import flip
313 class Dropout_layer(Layer):
314     """Dropout layer
315     """
316
317     def __init__(self, nn, rate=0):
318         """
319         rate is fraction of the input units to drop. 0 =< rate < 1
320         """
321         self.rate = rate
322         Layer.__init__(self, nn)
323         self.mask = [0]*self.num_inputs
324
325     def output_values(self, input_values, training=False):
326         """Returns the outputs for the input values.
327         It remembers the input values and mask for the backprop.
328         """
329         if training:
330             scaling = 1/(1-self.rate)
331             for i in range(self.num_inputs):
332                 self.mask[i] = 0 if flip(self.rate) else 1
333                 input_values[i] = self.mask[i]*input_values[i]*scaling
334         return input_values
335
336     def backprop(self, output_errors):
337         """Returns the derivative of the errors"""
338         for i in range(self.num_inputs):
339             self.input_errors[i] = output_errors[i]*self.mask[i]
340         return self.input_errors

```

8.5 Examples

The following constructs some neural networks.

```

learnNN.py — (continued)
342
343 def main():
344     """Sets up some global variables to allow for interaction
345     """
346     global data, nn3, nn3do
347     #data = Data_from_file('data/mail_reading.csv', target_index=-1)
348     #data = Data_from_file('data/mail_reading_consist.csv', target_index=-1)
349     data = Data_from_file('data/SPECT.csv', target_index=0) #, seed=12345)

```

```

350 #data = Data_from_file('data/carbool.csv', one_hot=True,
      target_index=-1, seed=123)
351 #data = Data_from_file('data/iris.data', target_index=-1)
352 #data = Data_from_file('data/if_x_then_y_else_z.csv', num_train=8,
      target_index=-1) # not linearly sep
353 #data = Data_from_file('data/holiday.csv', target_index=-1) #,
      num_train=19)
354 #data = Data_from_file('data/processed.cleveland.data', target_index=-1)
355 #random.seed(None)
356
357 # nn3 is has a single hidden layer of width 3
358 nn3 = NN(data, optimizer=SGD)
359 nn3.add_layer(Linear_complete_layer(nn3,3))
360 #nn3.add_layer(Sigmoid_layer(nn3))
361 nn3.add_layer(ReLU_layer(nn3))
362 nn3.add_layer(Linear_complete_layer(nn3, 1, final_layer=True)) # when
      output_type="boolean"
363 print("nn3")
364 nn3.learn(batch_size=100, num_iter = 1000, report_each=100)
365
366 # Print some training examples
367 #for eg in random.sample(data.train,10): print(eg,nn3.predictor(eg))
368
369 # Print some test examples
370 #for eg in random.sample(data.test,10): print(eg,nn3.predictor(eg))
371
372 # To see the weights learned in linear layers
373 # nn3.layers[0].weights
374 # nn3.layers[2].weights
375
376 # nn3do is like nn3 but with dropout on the hidden layer
377 nn3do = NN(data, optimizer=SGD)
378 nn3do.add_layer(Linear_complete_layer(nn3do,3))
379 #nn3.add_layer(Sigmoid_layer(nn3)) # comment this or the next
380 nn3do.add_layer(ReLU_layer(nn3do))
381 nn3do.add_layer(Dropout_layer(nn3do, rate=0.5))
382 nn3do.add_layer(Linear_complete_layer(nn3do, 1, final_layer=True))
383 #nn3do.learn(batch_size=100, num_iter = 1000, report_each=100)
384
385 if __name__ == "__main__":
386     main()

```

`NN_from_arch(dataset, architecture, optimizer, parameters)` creates a generic feedforward neural network with ReLU activation for the hidden layers. The dataset is needed as the input and output is determined by the data. The architecture is a list of the sizes of hidden layers. If the architecture is the empty list, this corresponds to linear or logistic regression. The optimizer is one of SGD, Momentum, RMS_Prop.

learnNN.py — (continued)

```

388 class NN_from_arch(NN):

```

```

389     def __init__(self, data, arch, optimizer=SGD, **hyperparams):
390         """arch is a list of widths of the hidden layers from bottom up.
391         opt is an optimizer (one of: SGD, Momentum, RMS_Prop)
392         hyperparams is the parameters of the optimizer
393         returns a neural network with ReLU activations on hidden layers
394         """
395         NN.__init__(self, data, optimizer=optimizer, **hyperparams)
396         for width in arch:
397             self.add_layer(Linear_complete_layer(self,width))
398             self.add_layer(ReLU_layer(self))
399         output_size = len(data.target.frange) if data.target.ftype ==
400             "categorical" else 1
401         self.add_layer(Linear_complete_layer(self,output_size,
402             final_layer=True))
403         hyperparams_string = ','.join(f"{p}={v}" for p,v in
404             hyperparams.items())
405         self.name = f"NN({arch},{optimizer.__name__}({hyperparams_string})"
406
407     def __str__(self):
408         return self.name
409
410 # nn3a = NN_from_arch(data, [3], SGD, lr=0.001)

```

8.6 Plotting Performance

You can plot the performance of various algorithms on the training and validation sets.

Figure 8.1 shows the training and validation performance on the SPECT dataset for the architectures given. The legend give the architecture, the optimizer, the options, and the evaluation dataset. The architecture [] is for logistic regression. Notice how, as the network gets larger the better they fit the training data, but can overfit more as the number of steps increases (probably because the probabilities get more extreme). These figures suggest that early stopping after 200-300 steps might provide best test performance.

The `plot_algs` method does all combinations of architectures, optimizers and learning rates. It plots both learning and validation errors. The output is only readable if two of these are singletons, and one varies (as in the examples).

The `plot_algs_opts` method is more general as it allows for different combinations of architectures, optimizers and learning rates, which makes more sense if, for example, the learning rate is set depending on the architecture and optimizer. It also allows other hyperparameters to be specified and varied.

```

learnNN.py — (continued)
409 from learnLinear import plot_steps
410 from learnProblem import Evaluate
411
412 # To show plots first choose a criterion to use

```

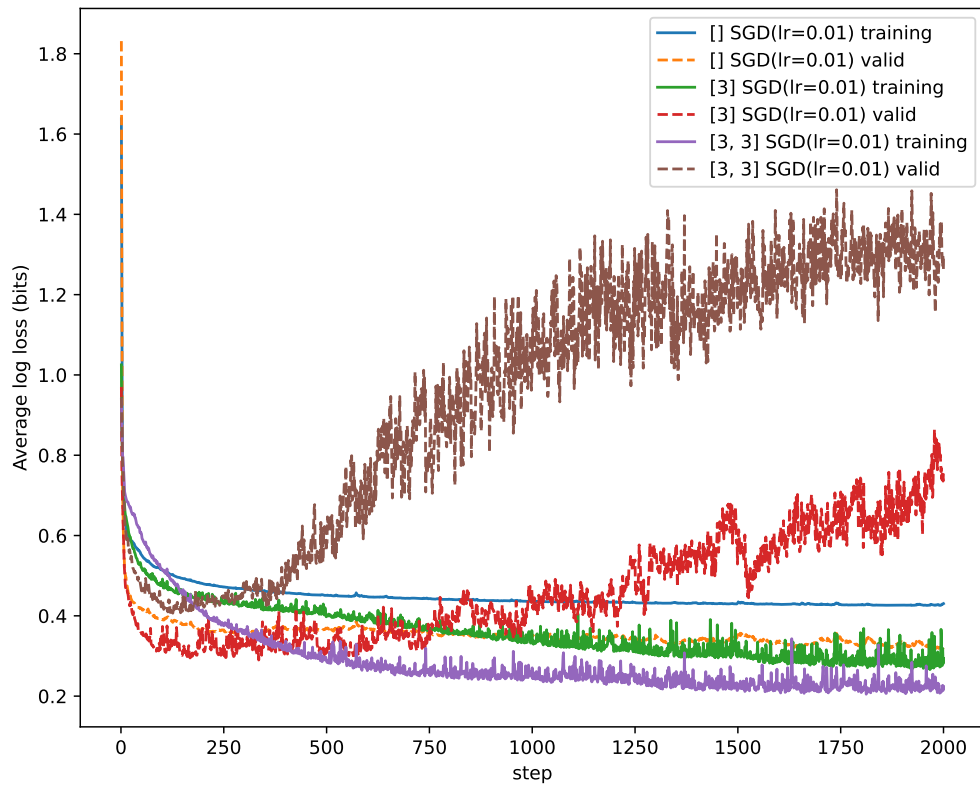

Figure 8.1: Plotting train and validation log loss for various architectures on SPECT dataset. Generated by `plot_algs(archs=[[[]],[3],[3,3]], opts=[SGD],lrs=[0.01],num_steps=2000)` Other runs might be different, as the validation set and the algorithm are stochastic.

```

413 | crit = Evaluate.log_loss # penalizes overconfident predictions (when wrong)
414 | # crit = Evaluate.accuracy # only considers mode
415 | # crit = Evaluate.squared_loss # penalizes overconfident predictions less
416 |
417 | def plot_algs(data, archs=[[3]], opts=[SGD],lrs=[0.1, 0.01,0.001,0.0001],
418 |             criterion=crit, num_steps=1000):
419 |     args = []
420 |     for arch in archs:
421 |         for opt in opts:
422 |             for lr in lrs:
423 |                 args.append((arch,opt,{'lr':lr}))
424 |     plot_algs_opts(data, args, criterion, num_steps)
425 |
426 | def plot_algs_opts(data, args, criterion=crit, num_steps=1000):
427 |     """args is a list of (architecture, optimizer, parameters)
428 |     for each of the corresponding triples it plots the learning rate"""
429 |     for (arch, opt, hyperparms) in args:
430 |         nn = NN_from_arch(data, arch, opt, **hyperparms)

```

```

431 |         plot_steps(data, learner = nn, criterion=crit, num_steps=num_steps,
432 |                   log_scale=False, legend_label=str(nn))

```

The following are examples of how to do hyperparameter optimization manually.

```

-----learnNN.py --- (continued)-----
434 ## first select good learning rates for each optimizer.
435 # plot_algs(data, archs=[[3]], opts=[SGD],lrs=[0.1, 0.01,0.001,0.0001])
436 # plot_algs(data, archs=[[3]], opts=[Momentum],lrs=[0.1,
      0.01,0.001,0.0001])
437 # plot_algs(data, archs=[[3]], opts=[RMS_Prop],lrs=[0.1,
      0.01,0.001,0.0001])
438
439 ## If they have the same best learning rate, compare the optimizers:
440 # plot_algs(data, archs=[[3]], opts=[SGD,Momentum,RMS_Prop],lrs=[0.01])
441
442 ## With different learning rates, compare the optimizer using:
443 # plot_algs_opts(data, args=([(3],SGD,{ 'lr':0.01}),
      ([3],Momentum,{ 'lr':0.1}), ([3],RMS_Prop,{ 'lr':0.001}))
444
445 # similarly select the best architecture, but the best learning rate might
      depend also on the architecture

```

The following tests are on the MNIST digit dataset. The original files are from <http://yann.lecun.com/exdb/mnist/>. This code assumes you use the csv files from Joseph Redmon (<https://pjreddie.com/projects/mnist-in-csv/> or <https://github.com/pjreddie/mnist-csv-png> or <https://www.kaggle.com/datasets/oddrational/mnist-in-csv>) and put them in the directory `../MNIST/`. Note that this is **very** inefficient; you would be better to use Keras or PyTorch. There are $28 * 28 = 784$ input units and 512 hidden units, which makes 401,408 parameters for the lowest linear layer. So don't be surprised if it takes many hours in AIPython (even if it only takes a few seconds in Keras).

Think about: with 10 classes what is the accuracy, absolute loss, squared loss, log loss (bits) for a naive guess (where the naive guess might depend on the criterion)?

```

-----learnNN.py --- (continued)-----
447 # Simplified version: (approx 6000 training instances)
448 # data_mnist = Data_from_file('../MNIST/mnist_train.csv', prob_test=0.9,
      target_index=0, target_type="categorical")
449
450 # Full version:
451 # data_mnist = Data_from_files('../MNIST/mnist_train.csv',
      '../MNIST/mnist_test.csv', target_index=0, target_type="categorical")
452
453 #nn_mnist = NN_from_arch(data_mnist, [32,10], SGD, lr=0.01)
454 # one epoch:

```

```

455 # start_time = time.perf_counter();nn_mnist.learn(batch_size=128,
      num_iter=len(data_mnist)/128 );end_time =
      time.perf_counter();print("Time:", end_time - start_time,"seconds")
456 # determine train error:
457 # data_mnist.evaluate_dataset(data_mnist.train, nn_mnist.predictor,
      Evaluate.accuracy)
458 # determine test error:
459 # data_mnist.evaluate_dataset(data_mnist.test, nn_mnist.predictor,
      Evaluate.accuracy)
460 # Print some random predictions:
461 # for eg in random.sample(data_mnist.test,10):
      print(data_mnist.target(eg), nn_mnist.predictor(eg),
      nn_mnist.predictor(eg)[data_mnist.target(eg)])
462 # Plot learning:
463 # plot_algs(data_mnist,archs=[[32],[32,8]], opts=[RMS_Prop], lrs=[0.01],
      data=data_mnist, num_steps=100)
464 # plot_algs(data_mnist,archs=[[8],[8,8,8],[8,8,8,8,8,8,8]],
      opts=[RMS_Prop], lrs=[0.01], data=data_mnist, num_steps=100)

```

Exercise 8.5 In the definition of *nn3* above, for each of the following, first hypothesize what will happen, then test your hypothesis, then explain whether you testing confirms your hypothesis or not. Test it for more than one data set, and use more than one run for each data set.

- Which fits the data better, having a sigmoid layer or a ReLU layer after the first linear layer?
- Which is faster to learn, having a sigmoid layer or a ReLU layer after the first linear layer? (Hint: Plot error as a function of steps).
- What happens if you have both the sigmoid layer and then a ReLU layer after the first linear layer and before the second linear layer?
- What happens if you have a ReLU layer then a sigmoid layer after the first linear layer and before the second linear layer?
- What happens if you have neither the sigmoid layer nor a ReLU layer after the first linear layer?

Exercise 8.6 Select one dataset and architecture.

- For each optimizer, use the validation set to choose settings for the hyperparameters, including when to stop, and the parameters of the optimizer (including the learning rate). (There is no need to do an exhaustive search, and remember that the runs are stochastic.) For the dataset and architecture chosen, which optimizer works best?
- Suggest another architecture which you conjecture would be better than the one used in (a) on the test set (after hyperparameter optimization). Is it better?

8.7 Language Tokenizer

Variants of the Byte Pair Encoding Algorithm (BPE) [Sennrich, Haddow, and Birch, 2016; Radford, Wu, Child, Luan, Amodei, and Sutskever, 2019] are the standard method for modern language models. The idea is simple. All of the characters are tokens. A new token is created by finding the most common pair of tokens and making that a new token. For example, if “di” and “ffere” are tokens, they can be joined to form the new token “differe”. A tokenizer can be trained on a subset of the training corpus.

There are three main challenges in using this algorithm:

- Building an efficient encoder which translates raw text (sequence of characters) into a sequence of tokens. It is important that this is efficient, as it will be used to encode the full training corpus. In the code here, we stream the text (using generators) building tokens using a variant of a trie, which branches on the next character, and returns the longest token that fits.
- Building the data structures needed to determine which tokens to create next. The problem is counting the number of occurrences of each pair of tokens in the corpus to determine which pair occurs the most often. Here we store a data structure that counts the number of times a pair of tokens appears (only representing the pairs that appear in the training corpus). For each new token, the pairs data structure is rebuilt by re-reading the corpus, which is not stored, but streamed on demand. This may be reasonable as the number of pairs is much less than the size of the corpus, and this is only done once initially, typically on a much smaller corpus. [To make this more efficient, an “obvious” way is to take the, say, the 10 top pairs to make into tokens. Why might this give something different?]
- Decoding, mapping a sequence of tokens to a sequence of characters. This is much simpler than the other two challenges. In the code below, the tokens are represented as the corresponding string. More commonly, tokens are numbered sequentially and there needs to be a mapping from index to token.

The corpus is taken from Project Gutenberg <https://www.gutenberg.org>, a library of free, out-of-copyright books. As our corpus, we use the text version of a diverse set of books:

- pg11 “Alice’s Adventures in Wonderland” by Lewis Carroll
- pg45 “Anne of Green Gables” by Lucy Maud Montgomery
- pg74 “The Adventures of Tom Sawyer, Complete” by Mark Twain

- pg84 “Frankenstein; Or, The Modern Prometheus” by Mary Wollstonecraft Shelley
- pg1342 “Pride and Prejudice” by Jane Austen
- pg1661 “The Adventures of Sherlock Holmes” by Arthur Conan Doyle

With a total of 2.925 million chars for 3.044 MB, uncompressed.

```

learnTokenizer.py — Language Tokenizer
11 import random
12 import pickle # for saving tokenizations
13 from display import Displayable
14
15 train_corpus = ["pg11.txt", "pg45.txt", "pg74.txt",
16                "pg84.txt", "pg1342.txt", "pg1661.txt"]
17 train_corpus_folder = "corpus/"
18 """Training corpus:
19     pg11 Alice's Adventures in Wonderland          163916 chars
20     pg45 Anne of Green Gables                    580415 chars
21     pg74 The Adventures of Tom Sawyer, Complete  412054 chars
22     pg84 Frankenstein; Or, The Modern Prometheus 438806 chars
23     pg1342 Pride and Prejudice                   748126 chars
24     pg1661 The Adventures of Sherlock Holmes     581565 chars
25 """

```

The following generates the characters from the files in the corpus. It replaces newlines with spaces and makes multiple spaces into a single space. Note that the standard generation (while c in file) generates lines. It is implemented as a pipeline of two generators: `file_to_chars0` replaces newlines with spaces and `file_to_chars` replaces multiple spaces with a single one.

```

learnTokenizer.py — (continued)
26 def file_to_chars0(file_name):
27     with open(file_name, 'r') as file:
28         while c := file.read(1):
29             if c == "\n":
30                 yield " "
31             else:
32                 yield c
33
34 def file_to_chars(file_name):
35     f2ch = file_to_chars0(file_name)
36     try:
37         lookahead = next(f2ch)
38     except StopIteration: # for empty files
39         return
40     for ch in f2ch:
41         if lookahead != ' ' or ch != ' ': #reject spaces after space
42             yield lookahead
43             lookahead = ch
44     yield lookahead

```

The following are utilities used by the code below. They are probably in some libraries, but it is simple to write them.

```

learnTokenizer.py — (continued)
46 def sequence_generators(*gens):
47     """
48     Given generators as arguments, generates the values of the generators
49     in turn
50     """
51     for g in gens:
52         # yield from g # does not work
53         for e in g:
54             yield e
55
56 class Multiset(object):
57     def __init__(self):
58         self.bag = {}
59
60     def add(self, elt):
61         if elt in self.bag:
62             self.bag[elt] += 1
63         else:
64             self.bag[elt] = 1
65
66     def items(self):
67         return self.bag.items()

```

The Tokenizer class builds three data structures:

- A list `tokens`, so that `tokens[k]` is the string for token `k`, where a token is an integer.
- `token_trie` is a dictionary that maps characters into a pair consisting of a token (or `None`) and a dictionary of the same form. It is used to map text into tokens. If the sequence of characters that reached a pair is a token, that token is the first element of the pair. If the sequence of characters that reached the pair is not a token, the first element of the pair is `None`.
- `token_pairs` is a multiset of token pairs so that `token_pairs[(t1, t2)]` is the number of times token `t1` is followed by token `t2`.

```

learnTokenizer.py — (continued)
68 class Tokenizer(Displayable):
69     def __init__(self, corpus = train_corpus,
70                 corpus_folder = train_corpus_folder,
71                 load_from_file = None):
72         self.corpus = corpus
73         self.corpus_folder = corpus_folder
74         if load_from_file is not None:
75             self.load(load_from_file)

```

```

76     else:
77         self.tokens = ["[UNK]", " ", ",", ".", ";", "<start>", "<end>"] #
            this could also be populated with characters in order.
78         self.token_trie = {c:[t,{}] for t,c in enumerate(self.tokens)}
            # char -> [tok, dict] tok is a token or None. dict is a
            token_trie
79         self.token_pairs = Multiset() # multiset of pairs of tokens
80         for file_name in corpus:
81             previous, _ = self.token_trie["<start>"] # start token
82             for ch in file_to_chars(corpus_folder+file_name):
83                 if ch not in self.token_trie:
84                     token = len(self.tokens)
85                     self.tokens.append(ch)
86                     self.token_trie[ch]= [token, {}]
87                 else:
88                     token,_ = self.token_trie[ch]
89                     if self.legal_token_pair(previous, token):
90                         self.token_pairs.add((previous, token))
91                     previous = token
92                 if self.legal_token_pair(previous, token):
93                     self.token_pairs.add((previous, token))
94         self.display(1, f"Corpus has {len(self.tokens)}
            single-character tokens.")

```

If any pair of tokens can form new tokens, it is possible to have "the", " the", "the " (note different placement of a space) all be different tokens. Think about how these pair up with "cat", " cat" or "cat " to form "the cat" (perhaps with spaces at the ends). Not allowing spaces to join to other tokens gives subword tokens, where no tokens contain spaces. If the second of the pair cannot be a space, spaces are only allowed at the start or middle of tokens.

learnTokenizer.py — (continued)

```

96     def legal_token_pair(self, previous, token):
97         """If there are restrictions on token pairs put them here. Otherwise
98         return True
99         the sets should probably be constants and only evaluated once.
100        """
101         #return True # no restrictions
102
103         # if token cannot be a space, it only allows spaces at start and
            middle of tokens:
104         return ( token not in {self.token_trie[ch][0] for ch in " ,.;"})
105
106         #If previous and token cannot both be " ", it only allows subword
            tokens:
107         #return (token not in {self.token_trie[ch][0] for ch in " ,.;"}
108         #         or previous not in {self.token_trie[ch][0]
109         #         for ch in " ,.;"})
110
111     def decode(self, token_list):
112         res = ""

```

```

113     for tok in token_list:
114         res += self.tokens[tok]
115     return res

```

One complication the code needs to handle is that not all prefixes of tokens are tokens. For example, suppose "ahead" is a token (created by joining "a" and "head"), and none of its prefixes other than "a" are tokens. The string "ahh..." returns the token "a", and "hh" becomes the lookahead string, which the parser should start again with and then use the rest of the text. The lookahead might not be used up by when generating the subsequent token. For example, if "ahead" were a token, the text "ahearne..." would have "ahear" read before it can conclude it is not the token "ahead", which may become the tokens "a"+"he"+"ar".

```

learnTokenizer.py — (continued)
117     def corpus_to_tokens(self):
118         for file_name in self.corpus:
119             char_generator = file_to_chars(self.corpus_folder+file_name)
120             yield from self.tokenize(char_generator)
121
122     def tokenize(self, string_input):
123         """generate tokens from a string.
124         """
125         gen_input = (c for c in string_input)
126         lookahead = []
127         unused = []
128         ended = False
129         while not ended:
130             dic = self.token_trie
131             unusedlist = list(unused)
132             self.display(3,f"start while {lookahead=} {unusedlist=}")
133             unused = (e for e in lookahead + unusedlist)
134             ended = True
135             for next_char in sequence_generators(unused, gen_input):
136                 if next_char not in self.token_trie:
137                     next_char = self.tokens[0] # unknown character
138                     ended = False
139                     self.display(3,f"{next_char=}")
140                 if next_char in dic:
141                     tok,dic = dic[next_char]
142                     if tok is not None: #dictionary entry is a token
143                         self.display(3,f"token={tok=} {self.tokens[tok]}")
144                         token=tok
145                         lookahead=[]
146                 else:
147                     lookahead.append(next_char)
148                     self.display(3,f"tok=None {token=}
149                                 {self.tokens[token]} {lookahead=}")
150             else:
151                 lookahead.append(next_char)

```

```

151         self.display(3, f"in else yielding {token=}
152             {self.tokens[token]} {lookahead=}")
153         yield token
154         break
155     else:
156         if not ended:
157             self.display(3, f"for ended yielding {token=}
158                 {self.tokens[token]} {lookahead=} {ended=}")
159             yield token

```

Exercise 8.7 Consider what happens when a token could be created in two different ways, such as “i”+“ng” or “in”+“g”. Before the token is created how would “ing” be tokenized? Would it be tokenized twice? Why or why not?

Given the number of tokens to end up with, `create_tokens` creates tokens from the current corpus. It assumes that there is a current multiset of pairs of tokens, from which it chooses the most common pair. It adds this to the token trie. The new token can be a subword of a current token or could extend the trie. It uses the generated sequence of tokens generated by the current tokens to create a new the multiset of pairs.

```

learnTokenizer.py — (continued)
159 def create_tokens(self, num_tokens):
160     while len(self.tokens) < num_tokens:
161         count, (t0,t1) = max((c,p) for (p,c) in
162             self.token_pairs.items())
163         new_token = len(self.tokens)
164         token_string = self.tokens[t0]+self.tokens[t1] # append tokens
165         self.display(0, f'{len(self.tokens)}: Creating token:
166             {self.tokens[t0]!r}+{self.tokens[t1]!r}'
167             f' -> {token_string!r} {count=}')
168         self.tokens.append(token_string)
169         self.add_to_trie(token_string, new_token)
170
171     # Rebuild pairs from scratch
172     self.token_pairs = Multiset()
173     generate_tokens = self.corpus_to_tokens()
174     prev = next(generate_tokens)
175     for token in generate_tokens:
176         if self.legal_token_pair(prev, token):
177             self.token_pairs.add((prev, token))
178         prev = token
179
180 def add_to_trie(self, token_string, new_token):
181     """Adds a new token to the current trie
182     token_string is the string that makes up the token
183     new_token is the index into tokens list.
184     """
185     token_trie = self.token_trie
186     for ch in token_string[:-1]:

```

```

185         if ch in token_trie:
186             (_, token_trie) = token_trie[ch]
187         else:
188             dct = {}
189             token_trie[ch] = [None,dct]
190             token_trie = dct
191     if token_string[-1] in token_trie:
192         token_trie[token_string[-1]][0] = new_token
193     else:
194         token_trie[token_string[-1]] = [new_token,{}]
195
196     # Saving and loading computed data structures
197     def save(self, filename="tokens.pkl"):
198         file = open(filename, 'wb')
199         pickle.dump((self.tokens,self.token_trie,self.token_pairs), file)
200     def load(self, filename="tokens.pkl"):
201         file = open(filename, 'rb')
202         (self.tokens,self.token_trie,self.token_pairs) = pickle.load(file)
203         self.display(0, f"Corpus has {len(self.tokens)} tokens.")
204
205     if __name__ == "__main__":
206         print("""# Try:
207 tok = Tokenizer()
208 tok.create_tokens(200)
209 # OR
210 tok = Tokenizer(load_from_file ="tokens_wd_1000.pkl") #"tokens.pkl")
211 #tok.load()
212 """)
213
214     # 10 most likely pairs:
215     # sorted((n, (tok.tokens[t1], tok.tokens[t2])) for ((t1,t2),n) in
216             tok.token_pairs.items())[-10:]
217     # what token will be created? create a new token: tok.create_tokens(201)
218     # how have the 10 most likely pairs changed?
219
220     # longest tokens:
221     # sorted([(len(e),e) for e in tok.tokens])[-20:]

```

Exercise 8.8 Why is “ the” (with a space) created before “the” (without a space), when “the” always appears more often than “ the”? Hint: create 113 tokens and look at the number of pairs with “ t” and “he” (with a space) versus “th” and “e” or “t” and “he” (without a space).

Exercise 8.9 When there are only subword tokens (see `legal_token_pair`), it can be more efficient to implement tokenization by having a word to count dictionary (multiset). Implement this.

Exercise 8.10 If there are only subword tokens, should space be a token? If it was, what is the proportion of tokens that spaces? If not, how can text be generated, when the text requires spaces between some, but not all, tokens?

8.8 Bigram with Empirical Probabilities

Except for the restrictions on what can be in a token, the multiset `token_pairs` contains enough information to determine the probability distribution of the words given the previous word, which is a bigram model (an n -gram model where $n = 2$). The model below uses empirical probabilities without regularization. (Regularization could be to use pseudo-counts as in a Dirichlet distribution.) Empirical probabilities are adequate for bigrams when generating text, but not for recognition as they give zero probability for pairs not in the training set. For n -grams for larger n , empirical probabilities can be undefined for word sequences not in the training set, and so are not suitable for generation or recognition.

```

_____learnNgram.py — Bigram and N-gram with embeddings_____
11 import random
12 from display import Displayable
13 from learnTokenizer import Multiset, Tokenizer
14
15 class Bigram(Displayable):
16     def __init__(self, tokenizer):
17         self.tokenizer = tokenizer
18         self.ttc = [[0 for _ in tokenizer.tokens] for _ in
19                    tokenizer.tokens] # dense
20         self.counts=[0 for _ in tokenizer.tokens]
21         # ttc[token1][token2] is the number of times token 1 is followed by
22         # token 2
23         generate_tokens = tokenizer.corpus_to_tokens()
24         prev = next(generate_tokens)
25         self.counts[prev] = 1
26         for token in generate_tokens:
27             self.ttc[prev][token] += 1
28             self.counts[token] += 1
29             prev = token
30
31     def generate(self, prompt, length, temp=1):
32         res = prompt+" " # copy prompt
33         ti = list(self.tokenizer.tokenize(prompt))[-1] # last token
34         for i in range(length):
35             ti = sample_i(self.ttc[ti], temp=temp)
36             res += self.tokenizer.tokens[ti]
37         return res
38
39     def dist(self, prompt):
40         """returns a sorted list of prob,string
41         """
42         ti = list(self.tokenizer.tokenize(prompt))[-1] # last token
43         unnorm = self.ttc[ti]
44         tot = sum(unnorm)

```

```

43         return sorted([(n/tot,self.tokenizer.tokens[i]) for (i,n) in
44                        enumerate(unnorm) if n>0])
45
46 def sample_i(probs, temp=1):
47     """Sample from an unnormalized probability distribution.
48     probs is a list of nonnegative numbers
49     """
50
51     #keys = range(len(probs)) if isinstance(probs,list) else probs.keys()
52     if isinstance(probs,list):
53         probs = {i:v for (i,v) in enumerate(probs)}
54     if temp != 1:
55         probs = {k:p**(1/temp) for k,p in probs.items()}
56     tot = sum(probs.values())
57     sm = 0
58     p = random.random()*tot
59     for i in probs:
60         sm += probs[i]
61         if p <= sm:
62             return i
63     assert False, f"sample_i has error with {probs=}"
64
65 # tok = Tokenizer(load_from_file ="tokens.pkl") #"tokens_wd_1000.pkl")
66 # tok.save("tokens.pkl")
67 # bg = Bigram(tok)
68 # bg.generate(" this", 30, temp=0.2)
69 # bg.generate(" she", 30, temp=0.2)
70
71 # To get the distribution of the top next words given a text
72 # bg.dist(" this")[-20:]
73
74 # To determine how many instances of each token there are:
75 # sorted(list(zip(bg.counts,tok.tokens)))
76 # To determine probability of most likely tokens:
77 # sorted(list(zip([c/sum(bg.counts) for c in bg.counts],tok.tokens)))[-30:]

```

8.9 N-Grams with token embeddings

Going beyond bigrams to arbitrary n-grams (looking $n - 1$ tokens in the past) using empirical probabilities is problematic as for many sequences of words there is no data. An alternative to using empirical probabilities is to use token features, represented as vectors.

The one-hot layer is an instance of the linear complete layer, designed when one of the inputs is 1 and others are zero, and the inputs are given (not learned) There are two main changes:

- It does not need to multiply by 0 or 1, but selects the input that would be

multiplied by 1.

- Backprop does not need to return an error as the inputs are always observed.

```

learnNgram.py — (continued)
78 from learnNN import NN, Layer, Linear_complete_layer, Batch_generator,
   RMS_Prop
79 from learnProblem import Data_set
80
81 class One_Hot_Layer(Linear_complete_layer):
82     """A complete linear layer where one input is 1 and the others are 0.
83     No need to multiple by 1 or 0.
84     """
85     def __init__(self, nn, num_inputs, num_outputs, limit=None,
86                 final_layer=False):
87         Linear_complete_layer.__init__(self, nn, num_outputs, limit,
88                                       final_layer,
89                                       num_inputs=num_inputs)
90
91     def output_values(self, input, training=False):
92         """Returns the outputs for the input values.
93         It remembers the input for the backprop.
94         """
95         self.display(3, f"One-hot layer inputs: {input}")
96         self.input=input
97         for out in range(self.num_outputs):
98             self.outputs[out] = (self.weights[input][out]
99                                 + self.weights[self.num_inputs][out])
100         self.display(3, f"One-hot layer {input=}, {self.outputs=}")
101         return self.outputs
102
103     def backprop(self, errors):
104         """Backpropagate errors, update weights, return input error.
105         errors is a list of size self.num_outputs
106         No need to return errors for layer's input as input is always data
107         """
108         self.display(3, f"One-hot Backprop. input: {self.input} output
109                       errors: {errors}")
110         for out in range(self.num_outputs):
111             inp=self.input
112             #self.input_errors[inp] = self.weights[inp][out] * errors[out]
113             self.delta[inp][out] += self.input * errors[out]
114             self.delta[self.num_inputs][out] += errors[out]
115             #self.display(3, f"One-hot layer backprop input errors:
116             #             {self.input_errors}")
117         #return self.input_errors
118
119 class Concat_Layers(Layer):
120     """A layer created by concatenating a list of layers.

```

```

117     Each layer has a single input value;
118         the input of the concatenation is list of these values
119     Output of the concatenation is the concatenation of the outputs
120     """
121     def __init__(self, nn, layers):
122         num_outputs = sum(layer.num_outputs for layer in layers)
123         self.display(3, f"Concat_Layers {layers=} {num_outputs=}")
124         Layer.__init__(self, nn, num_outputs)
125         self.layers = layers
126
127     def output_values(self, input_values, training=False):
128         ov = []
129         for layer, inp in zip(self.layers, input_values):
130             ov += layer.output_values(inp)
131         return ov
132
133     def backprop(self, out_errors):
134         # need to unpack the array of outputs to the output of each layer
135         res=[]
136         for layer in self.layers:
137             res.append(layer.backprop(out_errors[:layer.num_outputs]))
138             out_errors = out_errors[layer.num_outputs:]
139         return res
140
141 class N_gram_dataset(Data_set):
142     """creates dataset from slices of the token stream of length n
143     """
144     def __init__(self, n, tokenizer):
145         self.n = n
146         self.tokenizer = tokenizer
147         self.input_features = [lambda e, iv=i: e[iv] for i in range(n-1)]
148         self.target = lambda e: e[n-1]
149         self.target.ftype = "categorical"
150         self.target.frange = list(range(len(tokenizer.tokens)))
151         self.train = [] # don't print anything for training set
152         self.valid = []
153
154 class NGram_Batch_Generator(Batch_generator):
155     def __init__(self, tokenizer, n):
156         self.tokenizer = tokenizer
157         self.n = n
158         self.ngrams = self.Ngram_generator() # data generator
159
160     def Ngram_generator(self):
161         while True: # keep going through the corpus
162             token_gen = self.tokenizer.corpus_to_tokens()
163             self.context = [next(token_gen) for i in range(self.n)]
164             for token in token_gen:
165                 yield self.context
166                 self.context = self.context[1:]+[token]

```

```

167
168     def get_batch(self, batch_size):
169         return [next(self.ngrams) for i in range(batch_size)]
170
171 #Test:
172 # b = NGram_Batch_Generator(tok,5)
173 # b.get_batch(10)
174
175 class N_gram(NN):
176     def __init__(self, n, tokenizer, hidden_size, optimizer=None,
177                 **hyperparms):
178         self.n = n
179         self.tokenizer = tokenizer
180         dataset = N_gram_dataset(n, tokenizer)
181         NN.__init__(self, dataset,
182                    batch_gen=NGram_Batch_Generator(tokenizer, n),
183                    optimizer=optimizer, **hyperparms)
184         self.add_layer(
185             Concat_Layers(self,
186                           [One_Hot_Layer(self,
187                                           len(dataset.tokenizer.tokens),hidden_size) for i in
188                                           range(n-1)]))
189         # add hidden layers here
190         self.add_layer(Linear_complete_layer(self, len(tokenizer.tokens)))
191
192     def generate(self, prompt, length, temp=1):
193         res = prompt+"" # copy prompt (to include prompt in result)
194         toks = list(self.tokenizer.tokenize(prompt))
195         if len(toks) >= self.n-1:
196             context = toks[-self.n+1:]
197         else:
198             blank_token = self.tokenizer.token_trie[' '][0]
199             context = [blank_token]*(self.n-1-len(prompt)) + toks
200         for i in range(length):
201             ti = sample_i(self.predictor(context), temp=temp)
202             self.display(3,f"generate: {context=} {ti=}
203                         {self.tokenizer.tokens[ti]=}")
204             res += self.tokenizer.tokens[ti]
205             context = context[1:]+[ti]
206         return res
207
208 # tok = Tokenizer()
209 # tok.create_tokens(200)
210 # fiveg = N_gram(5, tok, 20, optimizer= RMS_Prop)
211 # fiveg.learn(batch_size=100, num_iter = 10000, report_each=10000000)
212 # import time
213 # st=time.perf_counter(); fiveg.learn(batch_size=100, num_iter = 10000,
214     report_each=10000000); et=time.perf_counter()
215 # fiveg.generate("the cat smiled and said ", 20)

```

```

211 # show distribution:
212 # sorted([(p,tok.tokens[t]) for (t,p) in
      fiveg.predictor(list(tok.tokenize("the cat smiled and
      said"))[-4:]).items()][-20:]]
213 # sorted([(p,tok.tokens[t]) for (t,p) in
      fiveg.predictor(list(tok.tokenize("the cat smiled and said
      "))[-4:]).items()][-20:]] #space after s
214 # what is the context:
215 # tok.decode(list(tok.tokenize("the cat smiled and said"))[-4:])
216 # tok.decode(list(tok.tokenize("and said")))

```

The above code is very slow. The neural network code is interpreted and run sequentially. It was not written to be efficient. For example, it appends the bias to the output of a layer to get the next input. Modern neural network toolkits are orders of magnitude faster. They compile to a form so that at run time the code is only doing the appropriate arithmetic functions, such as addition and multiplication, and is run on parallel hardware that is specialized to these forms expressions.

Keras is a front end for many efficient back ends. It is available from Python distributions such as <https://anaconda.org/channels/conda-forge/packages/keras/overview>. See https://keras.io/getting_started/. Chollet and Watson [2025] provides a good introduction to Keras.

For the following code to work, you need to download the test files, and create and save a tokenization.

```

_____learnNgramKeras.py — Bigram and N-gram with embeddings (using Keras)_____
11 ### learn n-gram with embeddings using Keras
12
13 import keras
14 import tensorflow as tf
15 import numpy as np
16 import random
17 from learnTokenizer import Tokenizer, Multiset, file_to_chars
18 import matplotlib.pyplot as plt
19
20 context_size = 20
21 embedding_size = 500
22
23 # load tokenizer that is already saved:
24 tok = Tokenizer(load_from_file ="tokens_wd_1000.pkl") #"tokens.pkl")
25 #otherwise:
26 #tok = Tokenizer()
27 # tok.create_tokens(1000)
28
29 # Get these books and put them in folder corpus_test/
30 # https://www.gutenberg.org/cache/epub/12/pg12.txt Through the
      Looking-Glass
31 # https://www.gutenberg.org/cache/epub/76/pg76.txt Adventures of
      Huckleberry Finn
32 # https://www.gutenberg.org/cache/epub/2701/pg2701.txt Moby Dick

```

```

33 # https://www.gutenberg.org/cache/epub/35461/pg35461.txt A Short History
    of the World
34 # (Which of these are similar to training books?)
35
36 test_corpus = ["pg12", "pg76", "pg2701", "pg35461"]
37 test_corpus_folder = "corpus_test/"
38 test_seqs =
    [np.array(list(tok.tokenize(file_to_chars(test_corpus_folder+fn+".txt"))))
    for fn in test_corpus]
39
40
41 token_seq = np.array(list(tok.corpus_to_tokens()))
42 unigram_inputs = np.array([ [] for _ in tok.corpus_to_tokens()])
43
44 def dataset_from_file(tokenizer, filename, context_size=context_size):
45     file_tokens =
46         np.array(list(tokenizer.tokenize(file_to_chars(filename))))
47     dataset = keras.utils.timeseries_dataset_from_array(
48         data = file_tokens[:-context_size],
49         targets = file_tokens[context_size:],
50         sequence_length = context_size
51     )
52     return dataset
53
54 class Unigram(object):
55     def __init__(self):
56         inputs = keras.Input(shape=(0,), dtype="int32")
57         embedding = keras.layers.Embedding(
58             input_dim = 0,
59             output_dim = len(tok.tokens)
60         )
61         output = keras.layers.Softmax()(embedding(inputs))
62         self.model = keras.Model(inputs, output, name=f"Unigram")
63         self.model.compile(optimizer="adam", # "rmsprop",
64                             loss="sparse_categorical_crossentropy",
65                             metrics=["sparse_categorical_accuracy"])
66         self.model.summary()
67
68 #unigram = Unigram()
69 #unigram.model.fit(unigram_inputs, token_seq, epochs=2)

```

The following implements an embedding based N-gram model. Each word has an embedding. The embedding for the context_size previous words are concatenated, and a fully connected layer predicts the next word.

learnNgramKeras.py — (continued)

```

70 optimizer = "adam" # "rmsprop" #
71
72 class NGram(object):
73     def __init__(self,
74                 context_size = context_size,
75                 embedding_size = embedding_size,

```

```

76         dataset = None
77     ):
78
79     self.context_size = context_size
80     self.embedding_size = embedding_size
81     if dataset is None:
82         self.dataset = keras.utils.timeseries_dataset_from_array(
83             data = token_seq[:-self.context_size],
84             targets = token_seq[self.context_size:],
85             sequence_length = self.context_size,
86             shuffle=True
87         )
88     else:
89         self.dataset = dataset
90     inputs = keras.Input(shape=(self.context_size,), dtype="int32")
91     embedding = keras.layers.Embedding(
92         input_dim = len(tok.tokens),
93         output_dim = self.embedding_size
94         #,mask_zero=True
95     )
96     emb = embedding(inputs)
97     con = keras.layers.Flatten()(emb)
98     output = keras.layers.Dense(len(tok.tokens),
99         activation="softmax")(con)
100     self.model = keras.Model(inputs, output,
101         name=f"NGram_{context_size}_{embedding_size}")
102
103     self.model.compile(optimizer=optimizer,
104         loss="sparse_categorical_crossentropy", #keras.losses.SparseCategoricalCrossentropy(),
105         #from_logits=False),
106         metrics=["sparse_categorical_accuracy"])
107     print(f"NGram({context_size}, {embedding_size})")
108     self.model.summary() # get statistics
109
110
111     def generate(self, prompt, max_length=158):
112         """generates a completion of prompt up to max_length tokens.
113         filler is used so a prompt less than the context_size does not give
114         an error
115         """
116         filler = [random.randint(0, len(tok.tokens)-1) for _ in
117             range(self.context_size)]
118         tokens = filler + list(tok.tokenize(prompt))
119         #print(f"{tokens=}")
120         prompt_length = len(tokens)
121         for _ in range(max_length+context_size - prompt_length):
122             prediction =
123                 self.model(keras.ops.convert_to_numpy([tokens[-self.context_size:]])
124             tokens.append(np.argmax(prediction).item())
125         #print(f"{tokens=}")
126         return "".join(tok.tokens[t] for t in tokens[self.context_size:])

```

```

120
121
122 #ngram = NGram(context_size = 20, embedding_size = 500)
123 #ngram.model.fit(ngram.dataset, epochs=100)
124
125 # generate("the monster said to Alice")
126 # 'the monster said to Alice, jumped up and down in an agony of terror.
    "Oh, there goes his _precious_ nose!" as an unusually large saucepan
    flew close by it, and'
127
128 # generate(" I dare not expect such success, Alice") # " I dare not expect
    such success, " from Frankenstein
129 # ' I dare not expect such success, Alice, in pictures, making it the
    trust you, and making them the very politeness to sitting for a
    moment, silence, she said, very stiffly, to Elizabeth,-- "I hope you
    are well, Miss Bennet'
130
131 # Testing:
132 # test1 =dataset_from_file(tok, 'corpus_test/pg12.txt')
133 # ngram.model.evaluate(test1)
134
135 def plot_errors(context_sizes = [4],
136                 embedding_sizes = [10],
137                 epochs = 10,
138                 repeat_epochs = 1 # must be > 0
139                 ):
140     """
141     exactly one of repeat_epochs, len(context_sizes), len(embedding_sizes)
        should be greater than one.
142     That becomes the x-axis in the plot.
143     The others must be 1.
144     if repeat_epochs>1, normally epochs=1 (so it plots each epoch)
145     """
146     global fig, axs, train_results, test_results # so they can be checked
        later
147     error_name = ['loss', 'accuracy']
148     train_results = []
149     test_results = [[] for _ in test_corpus]
150     plt.ion()
151     fig, axs = plt.subplots(1,2)
152     #ax.set_xscale('log') # change between log and linear scale
153     if repeat_epochs > 1:
154         xlabel = "Epochs"
155         xvalues = list(range(epochs,repeat_epochs*epochs+epochs,epochs))
156         title = f"context_size={context_sizes[0]},
            embedding_size={embedding_sizes[0]}, {optimizer=}"
157     if len(context_sizes) > 1:
158         xlabel = "Context size"
159         xvalues = context_sizes
160         title = f"epochs={epochs}, embedding_size={embedding_sizes[0]},

```

```

        {optimizer=}"
161  if len(embedding_sizes) > 1:
162      xlabel = "Embedding size"
163      xvalues = embedding_sizes
164      title = f"epochs={epochs}, context_size={context_sizes[0]},
        {optimizer=}"
165  for err in range(2):
166      axs[err].set_xlabel(xlabel)
167      axs[err].set_ylabel(error_name[err])
168  fig.suptitle(title)
169  for context_size in context_sizes:
170      dataset = keras.utils.timeseries_dataset_from_array(
171          data = token_seq[:-context_size],
172          targets = token_seq[context_size:],
173          sequence_length = context_size,
174          shuffle=True
175      )
176      test_datasets = [keras.utils.timeseries_dataset_from_array(
177          data = test_seq[:-context_size],
178          targets = test_seq[context_size:],
179          sequence_length = context_size,
180          shuffle=True
181      ) for test_seq in test_seqs]
182  for embedding_size in embedding_sizes:
183      ngram = NGram(context_size = context_size,
184                   embedding_size = embedding_size,
185                   dataset=dataset)
186      for ep in range(repeat_epochs):
187          print(f"Training: ({context_size=}, {embedding_size=},
188                repeat# {ep+1})")
189          hist = ngram.model.fit(dataset, epochs=epochs)
190          train_results.append(ngram.model.evaluate(dataset))
191          print("Test:")
192          for i in range(len(test_corpus)):
193              test_results[i].append(ngram.model.evaluate(test_datasets[i]))
194  for err in range(2):
195      axs[err].plot(xvalues, [res[err] for res in train_results],
196                    label="training")
197      for i in range(len(test_corpus)):
198          axs[err].plot(xvalues, [res[err] for res in test_results[i]],
199                        label=test_corpus[i])
200      axs[err].legend()
201  # plot_errors([10],[20],1,100)
202  # plot_errors([10],list(range(1,202,10)),10,1)
203  # plot_errors(list(range(1,52,5)),[20],10,1)

```

Reasoning with Uncertainty

9.1 Representing Probabilistic Models

A probabilistic model uses the same definition of a variable as a CSP (Section 4.1.1, page 69). A variable consists of a name, a domain and an optional (x,y) position (for displaying). The domain of a variable is a list or a tuple, as the ordering matters for some representation of factors.

9.2 Representing Factors

A **factor** is, mathematically, a function from variables into a number; that is, given a value for each of its variable, it gives a number. Factors are used for conditional probabilities, utilities in the next chapter, and are explicitly constructed by some algorithms (in particular, variable elimination).

A variable assignment, or just an **assignment**, is represented as a $\{variable : value\}$ dictionary. A factor can be evaluated when all of its variables are assigned. This is implemented in the `can_evaluate` method which can be overridden for representations that don't require all variable be assigned (such as decision trees). The method `get_value` evaluates the factor for an assignment. The assignment can include extra variables not in the factor. This method needs to be defined for every subclass.

```
_____probFactors.py — Factors for graphical models_____
11 from display import Displayable
12 import math
13
14 class Factor(Displayable):
15     nextid=0 # each factor has a unique identifier; for printing
16
```

```

17 def __init__(self, variables, name=None):
18     self.variables = variables # list of variables
19     if name:
20         self.name = name
21     else:
22         self.name = f"f{Factor.nextid}"
23         Factor.nextid += 1
24
25 def can_evaluate(self, assignment):
26     """True when the factor can be evaluated in the assignment
27     assignment is a {variable:value} dict
28     """
29     return all(v in assignment for v in self.variables)
30
31 def get_value(self, assignment):
32     """Returns the value of the factor given the assignment of values
33     to variables.
34     Needs to be defined for each subclass.
35     """
36     assert self.can_evaluate(assignment)
37     raise NotImplementedError("get_value") # abstract method

```

The method `__str__` returns a brief definition (like `f7(X,Y,Z)`). The method `to_table` returns string representations of a table showing all of the assignments of values to variables, and the corresponding value.

```

_____probFactors.py — (continued)_____
38 def __str__(self):
39     """returns a string representing a summary of the factor"""
40     return f"{self.name}({'.'.join(str(var) for var in
41         self.variables)})"
42
43 def to_table(self, variables=None, given={}):
44     """returns a string representation of the factor.
45     Allows for an arbitrary variable ordering.
46     variables is a list of the variables in the factor
47     (can contain other variables)"""
48     if variables==None:
49         variables = [v for v in self.variables if v not in given]
50     else: #enforce ordering and allow for extra variables in ordering
51         variables = [v for v in variables if v in self.variables and v
52             not in given]
53     head = "\t".join(str(v) for v in variables)+"\t"+self.name
54     return head+"\n"+self.ass_to_str(variables, given, variables)
55
56 def ass_to_str(self, vars, asst, allvars):
57     #print(f"ass_to_str({vars}, {asst}, {allvars})")
58     if vars:
59         return "\n".join(self.ass_to_str(vars[1:], {**asst,
60             vars[0]:val}, allvars)
61             for val in vars[0].domain)

```

```

59     else:
60         val = self.get_value(asst)
61         val_st = "{:.6f}".format(val) if isinstance(val, float) else
           str(val)
62         return "\t".join(str(asst[var]) for var in allvars)
63             + "\t"+val_st)
64
65     __repr__ = __str__

```

9.3 Conditional Probability Distributions

A **conditional probability distribution (CPD)** is a factor that represents a conditional probability. A CPD representing $P(X \mid Y_1 \dots Y_k)$ is a factor, which given values for X and each Y_i returns a number.

```

_____probFactors.py — (continued)_____
67 class CPD(Factor):
68     def __init__(self, child, parents):
69         """represents P(variable | parents)
70         """
71         self.parents = parents
72         self.child = child
73         Factor.__init__(self, parents+[child], name=f"Probability")
74
75     def __str__(self):
76         """A brief description of a factor using in tracing"""
77         if self.parents:
78             return f"P({self.child}|{' '.join(str(p) for p in
           self.parents)})"
79         else:
80             return f"P({self.child})"
81
82     __repr__ = __str__

```

A constant CPD has no parents, and has probability 1 when the variable has the value specified, and 0 when the variable has a different value.

```

_____probFactors.py — (continued)_____
84 class ConstantCPD(CPD):
85     def __init__(self, variable, value):
86         CPD.__init__(self, variable, [])
87         self.value = value
88     def get_value(self, assignment):
89         return 1 if self.value==assignment[self.child] else 0

```

9.3.1 Logistic Regression

A **logistic regression** CPD, for Boolean variable X represents $P(X=True \mid Y_1 \dots Y_k)$, using $k + 1$ real-valued weights so

$$P(X=True \mid Y_1 \dots Y_k) = \text{sigmoid}(w_0 + \sum_i w_i Y_i)$$

where for Boolean Y_i , True is represented as 1 and False as 0.

```

_____probFactors.py — (continued)_____
91 from learnLinear import sigmoid, logit
92
93 class LogisticRegression(CPD):
94     def __init__(self, child, parents, weights):
95         """A logistic regression representation of a conditional
96             probability.
97             child is the Boolean (or 0/1) variable whose CPD is being defined
98             parents is the list of parents
99             weights is list of parameters, such that weights[i+1] is the weight
100             for parents[i]
101             weights[0] is the bias.
102         """
103         assert len(weights) == 1+len(parents)
104         CPD.__init__(self, child, parents)
105         self.weights = weights
106
107     def get_value(self, assignment):
108         assert self.can_evaluate(assignment)
109         prob = sigmoid(self.weights[0]
110                       + sum(self.weights[i+1]*assignment[self.parents[i]]
111                             for i in range(len(self.parents))))
112         if assignment[self.child]: #child is true
113             return prob
114         else:
115             return (1-prob)

```

9.3.2 Noisy-or

A **noisy-or**, for Boolean variable X with Boolean parents $Y_1 \dots Y_k$ is parametrized by $k + 1$ parameters p_0, p_1, \dots, p_k , where each $0 \leq p_i \leq 1$. The semantics is defined as though there are $k + 1$ hidden variables $Z_0, Z_1 \dots Z_k$, where $P(Z_0) = p_0$ and $P(Z_i \mid Y_i) = p_i$ for $i \geq 1$, and where X is true if and only if $Z_0 \vee Z_1 \vee \dots \vee Z_k$ (where \vee is “or”). Thus X is false if all of the Z_i are false. Intuitively, Z_0 is the probability of X when all Y_i are false and each Z_i is a noisy (probabilistic) measure that Y_i makes X true, and X only needs one to make it true.

```

_____probFactors.py — (continued)_____
115 class NoisyOR(CPD):
116     def __init__(self, child, parents, weights):

```

```

117     """A noisy representation of a conditional probability.
118     variable is the Boolean (or 0/1) child variable whose CPD is being
        defined
119     parents is the list of Boolean (or 0/1) parents
120     weights is list of parameters, such that weights[i+1] is the weight
        for parents[i]
121     """
122     assert len(weights) == 1+len(parents)
123     CPD.__init__(self, child, parents)
124     self.weights = weights
125
126     def get_value(self,assignment):
127         assert self.can_evaluate(assignment)
128         probfalse = (1-self.weights[0])*math.prod(1-self.weights[i+1]
129                                                     for i in range(len(self.parents))
130                                                     if assignment[self.parents[i]])
131         if assignment[self.child]: # child is assigned True in assignment
132             return 1-probfalse
133         else:
134             return probfalse

```

9.3.3 Tabular Factors and Prob

A **tabular factor** is a factor that represents each assignment of values to variables separately. It is represented by a Python array (or Python dict). If the variables are V_1, V_2, \dots, V_k , the value of $f(V_1 = v_1, V_2 = v_2, \dots, V_k = v_k)$ is stored in $f[v_1][v_2] \dots [v_k]$.

If the domain of V_i is $[0, \dots, n_i - 1]$ it can be represented as an array. Otherwise it can use a dictionary. Python is nice in that it doesn't care, whether an array or dict is used **except when enumerating the values**; enumerating a dict gives the keys (the variables) but enumerating an array gives the values. So we had to be careful not to enumerate the values.

probFactors.py — (continued)

```

136 class TabFactor(Factor):
137
138     def __init__(self, variables, values, name=None):
139         Factor.__init__(self, variables, name=name)
140         self.values = values
141
142     def get_value(self, assignment):
143         return self.get_val_rec(self.values, self.variables, assignment)
144
145     def get_val_rec(self, value, variables, assignment):
146         if variables == []:
147             return value
148         else:
149             return self.get_val_rec(value[assignment[variables[0]]],
150                                   variables[1:],assignment)

```

Prob is a factor that represents a conditional probability by enumerating all of the values.

```

_____probFactors.py — (continued) _____
152 class Prob(CPD, TabFactor):
153     """A factor defined by a conditional probability table"""
154     def __init__(self, var, pars, cpt, name=None):
155         """Creates a factor from a conditional probability table, cpt
156         The cpt values are assumed to be for the ordering par+[var]
157         """
158         TabFactor.__init__(self, pars+[var], cpt, name)
159         self.child = var
160         self.parents = pars

```

9.3.4 Decision Tree Representations of Factors

A decision tree representation of a conditional probability of a child variable is either:

- `IFeq(var, val, true_cond, false_cond)` where `true_cond` and `false_cond` are decision trees. `true_cond` is used if variable `var` has value `val` in an assignment; `false_cond` is used if `var` has a different value
- a deterministic functions that has probability 1 if a parent has the same value as the child (using `SameAs(parent)`)
- a distribution over the child variable (using `Dist(dict)`).

Note that not all parents need to be assigned to evaluate the decision tree; it only needs a branch down the tree that gives the distribution.

```

_____probFactors.py — (continued) _____
162 class ProbDT(CPD):
163     def __init__(self, child, parents, dt):
164         CPD.__init__(self, child, parents)
165         self.dt = dt
166
167     def get_value(self, assignment):
168         return self.dt.get_value(assignment, self.child)
169
170     def can_evaluate(self, assignment):
171         return self.child in assignment and self.dt.can_evaluate(assignment)

```

Decision trees are made up of conditions; here equality of a value and a variable:

```

_____probFactors.py — (continued) _____
173 class IFeq:
174     def __init__(self, var, val, true_cond, false_cond):
175         self.var = var

```

```

176     self.val = val
177     self.true_cond = true_cond
178     self.false_cond = false_cond
179
180     def get_value(self, assignment, child):
181         """ IFeq(var, val, true_cond, false_cond)
182         value of true_cond is used if var has value val in assignment,
183         value of false_cond is used if var has a different value
184         """
185         if assignment[self.var] == self.val:
186             return self.true_cond.get_value(assignment, child)
187         else:
188             return self.false_cond.get_value(assignment, child)
189
190     def can_evaluate(self, assignment):
191         if self.var not in assignment:
192             return False
193         elif assignment[self.var] == self.val:
194             return self.true_cond.can_evaluate(assignment)
195         else:
196             return self.false_cond.can_evaluate(assignment)

```

The following is a deterministic function that is true if the parent has the same value as the child. This is used for deterministic conditional probabilities (as is common for causal models, as described in Chapter 11).

probFactors.py — (continued)

```

198 class SameAs:
199     def __init__(self, parent):
200         """1 when child has same value as parent, otherwise 0"""
201         self.parent = parent
202
203     def get_value(self, assignment, child):
204         return 1 if assignment[child]==assignment[self.parent] else 0
205
206     def can_evaluate(self, assignment):
207         return self.parent in assignment

```

At the leaves are distributions over the child variable.

probFactors.py — (continued)

```

209 class Dist:
210     def __init__(self, dist):
211         """Dist is an array or dictionary indexed by value of current
212         child"""
213         self.dist = dist
214
215     def get_value(self, assignment, child):
216         return self.dist[assignment[child]]
217
218     def can_evaluate(self, assignment):
219         return True

```

The following shows a decision representation of the Example 9.18 of Poole and Mackworth [2023]. When the Action is to go out, the probability is a function of rain; otherwise it is a function of full.

```

_____probFactors.py — (continued)_____
220 ##### A decision tree representation Example 9.18 of AIFCA 3e
221 from variable import Variable
222
223 boolean = [False, True]
224
225 action = Variable('Action', ['go_out', 'get_coffee'], position=(0.5,0.8))
226 rain = Variable('Rain', boolean, position=(0.2,0.8))
227 full = Variable('Cup Full', boolean, position=(0.8,0.8))
228
229 wet = Variable('Wet', boolean, position=(0.5,0.2))
230 p_wet = ProbDT(wet,[action,rain,full],
231               IFeq(action, 'go_out',
232                     IFeq(rain, True, Dist([0.2,0.8]), Dist([0.9,0.1])),
233                     IFeq(full, True, Dist([0.4,0.6]), Dist([0.7,0.3])))))
234
235 # See probRC for wetBN which expands this example to a complete network

```

9.4 Graphical Models

A graphical model consists of a title, a set of variables, and a set of factors.

```

_____probGraphicalModels.py — Graphical Models and Belief Networks_____
11 from display import Displayable
12 from variable import Variable
13 from probFactors import CPD, Prob
14 import matplotlib.pyplot as plt
15
16 class GraphicalModel(Displayable):
17     """The class of graphical models.
18     A graphical model consists of a title, a set of variables and a set of
19     factors.
20
21     vars is a set of variables
22     factors is a set of factors
23     """
24     def __init__(self, title, variables=None, factors=None):
25         self.title = title
26         self.variables = variables
27         self.factors = factors

```

A **belief network** (also known as a **Bayesian network**) is a graphical model where all of the factors are conditional probabilities, and every variable has a conditional probability of it given its parents. This checks the first condi-

tion (that all factors are conditional probabilities), and builds some useful data structures.

```

_____probGraphicalModels.py — (continued) _____
28 class BeliefNetwork(GraphicalModel):
29     """The class of belief networks."""
30
31     def __init__(self, title, variables, factors):
32         """vars is a set of variables
33         factors is a set of factors. All of the factors are instances of
34         CPD (e.g., Prob).
35         """
36         GraphicalModel.__init__(self, title, variables, factors)
37         assert all(isinstance(f,CPD) for f in factors), factors
38         self.var2cpt = {f.child:f for f in factors}
39         self.var2parents = {f.child:f.parents for f in factors}
40         self.children = {n:[] for n in self.variables}
41         for v in self.var2parents:
42             for par in self.var2parents[v]:
43                 self.children[par].append(v)
44         self.topological_sort_saved = None

```

The following creates a topological sort of the nodes, where the parents of a node come before the node in the resulting order. This is based on Kahn's algorithm from 1962.

```

_____probGraphicalModels.py — (continued) _____
45 def topological_sort(self):
46     """creates a topological ordering of variables such that the
47     parents of
48     a node are before the node.
49     """
50     if self.topological_sort_saved:
51         return self.topological_sort_saved
52     next_vars = {n for n in self.var2parents if not self.var2parents[n]}
53     self.display(3,'topological_sort: next_vars',next_vars)
54     top_order=[]
55     while next_vars:
56         var = next_vars.pop()
57         self.display(3,'select variable',var)
58         top_order.append(var)
59         next_vars -= {ch for ch in self.children[var]
60                     if all(p in top_order for p in
61                       self.var2parents[ch])}
62         self.display(3,'var_with_no_parents_left',next_vars)
63     self.display(3,"top_order",top_order)
64     assert
65         set(top_order)==set(self.var2parents), (top_order,self.var2parents)
66     self.topologicalsort_saved=top_order
67     return top_order

```

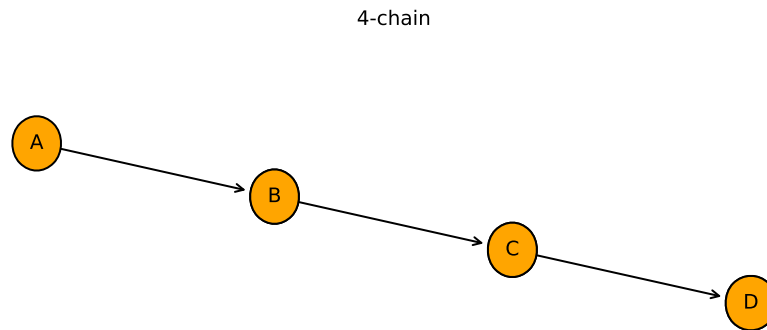
Figure 9.1: `bn_4ch.show()`

9.4.1 Showing Belief Networks

The **show** method uses matplotlib to show the graphical structure of a belief network.

```

-----probGraphicalModels.py --- (continued) -----
66  def show(self, fontsize=10, facecolor='orange'):
67      plt.ion() # interactive
68      fig, ax = plt.subplots()
69      ax.set_axis_off()
70      ax.set_title(self.title, fontsize=fontsize)
71      bbox =
72          dict(boxstyle="round4,pad=1.0,rounding_size=0.5",facecolor=facecolor)
73      for var in self.variables: #reversed(self.topological_sort()):
74          for par in self.var2parents[var]:
75              ax.annotate(var.name, par.position, xytext=var.position,
76                          arrowprops={'arrowstyle':'<-'},bbox=bbox,
77                          ha='center', va='center',
78                          fontsize=fontsize)
79
80      for var in self.variables:
81          x,y = var.position
82          ax.text(x,y,var.name,bbox=bbox,ha='center', va='center',
83                  fontsize=fontsize)

```

9.4.2 Example Belief Networks

A Chain of 4 Variables

The first example belief network is a simple chain $A \rightarrow B \rightarrow C \rightarrow D$, shown in Figure 9.1.

Please do not change this, as it is the example used for testing.

```

-----probGraphicalModels.py --- (continued) -----
81 ##### Simple Example Used for Unit Tests #####

```

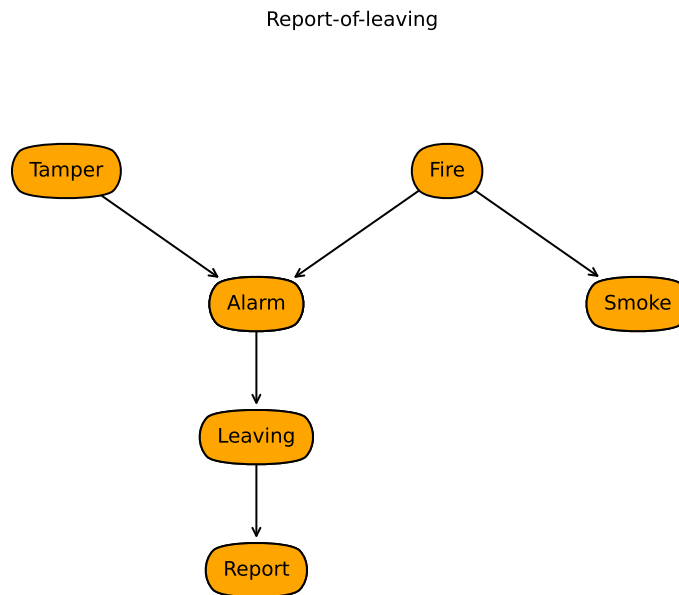

Figure 9.2: The report-of-leaving belief network

```

82 | boolean = [False, True]
83 | A = Variable("A", boolean, position=(0,0.8))
84 | B = Variable("B", boolean, position=(0.333,0.7))
85 | C = Variable("C", boolean, position=(0.666,0.6))
86 | D = Variable("D", boolean, position=(1,0.5))
87 |
88 | f_a = Prob(A,[],[0.4,0.6])
89 | f_b = Prob(B,[A],[[0.9,0.1],[0.2,0.8]])
90 | f_c = Prob(C,[B],[[0.6,0.4],[0.3,0.7]])
91 | f_d = Prob(D,[C],[[0.1,0.9],[0.75,0.25]])
92 |
93 | bn_4ch = BeliefNetwork("4-chain", {A,B,C,D}, {f_a,f_b,f_c,f_d})

```

Report-of-Leaving Example

The second belief network, `bn_report`, is Example 9.13 of Poole and Mackworth [2023] (<http://artint.info>). The output of `bn_report.show()` is shown in Figure 9.2 of this document.

probExamples.py — Example belief networks

```

11 | from variable import Variable
12 | from probFactors import CPD, Prob, LogisticRegression, NoisyOR, ConstantCPD
13 | from probGraphicalModels import BeliefNetwork
14 |

```

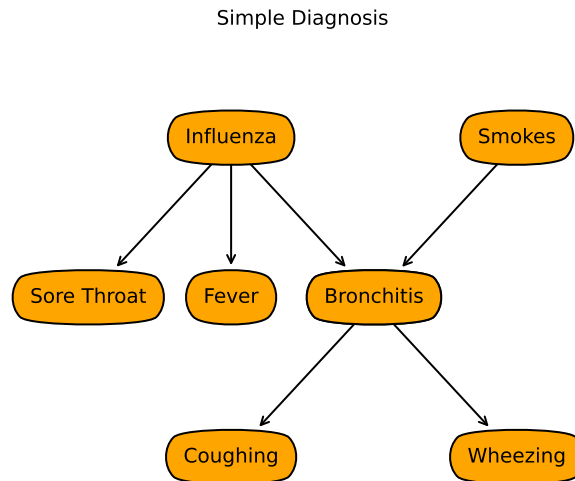

Figure 9.3: Simple diagnosis example; `simple_diagnosis.show()`

```

15 # Belief network report-of-leaving example (Example 9.13 shown in Figure
    9.3) of
16 # Poole and Mackworth, Artificial Intelligence, 2023 http://artint.info
17 boolean = [False, True]
18
19 Alarm = Variable("Alarm", boolean, position=(0.366,0.5))
20 Fire = Variable("Fire", boolean, position=(0.633,0.75))
21 Leaving = Variable("Leaving", boolean, position=(0.366,0.25))
22 Report = Variable("Report", boolean, position=(0.366,0.0))
23 Smoke = Variable("Smoke", boolean, position=(0.9,0.5))
24 Tamper = Variable("Tamper", boolean, position=(0.1,0.75))
25
26 f_ta = Prob(Tamper, [], [0.98, 0.02])
27 f_fi = Prob(Fire, [], [0.99, 0.01])
28 f_sm = Prob(Smoke, [Fire], [[0.99, 0.01], [0.1, 0.9]])
29 f_al = Prob(Alarm, [Fire, Tamper], [[[0.9999, 0.0001], [0.15, 0.85]], [[0.01,
    0.99], [0.5, 0.5]]])
30 f_lv = Prob(Leaving, [Alarm], [[0.999, 0.001], [0.12, 0.88]])
31 f_re = Prob(Report, [Leaving], [[0.99, 0.01], [0.25, 0.75]])
32
33 bn_report = BeliefNetwork("Report-of-leaving",
    {Tamper, Fire, Smoke, Alarm, Leaving, Report},
34 {f_ta, f_fi, f_sm, f_al, f_lv, f_re})
  
```

Simple Diagnostic Example

This is the “simple diagnostic example” of Exercise 9.1 of Poole and Mackworth [2023], reproduced here as Figure 9.3

probExamples.py — (continued)

```

36 # Belief network simple-diagnostic example (Exercise 9.3 shown in Figure
    9.39) of
37 # Poole and Mackworth, Artificial Intelligence, 2023 http://artint.info
38
39 Influenza = Variable("Influenza", boolean, position=(0.4,0.8))
40 Smokes = Variable("Smokes", boolean, position=(0.8,0.8))
41 SoreThroat = Variable("Sore Throat", boolean, position=(0.2,0.5))
42 HasFever = Variable("Fever", boolean, position=(0.4,0.5))
43 Bronchitis = Variable("Bronchitis", boolean, position=(0.6,0.5))
44 Coughing = Variable("Coughing", boolean, position=(0.4,0.2))
45 Wheezing = Variable("Wheezing", boolean, position=(0.8,0.2))
46
47 p_infl = Prob(Influenza,[],[0.95,0.05])
48 p_smokes = Prob(Smokes,[],[0.8,0.2])
49 p_sth = Prob(SoreThroat,[Influenza],[[0.999,0.001],[0.7,0.3]])
50 p_fever = Prob(HasFever,[Influenza],[[0.99,0.05],[0.9,0.1]])
51 p_bronc = Prob(Bronchitis,[Influenza,Smokes],[[0.9999, 0.0001], [0.3,
    0.7]], [[0.1, 0.9], [0.01, 0.99]])
52 p_cough = Prob(Coughing,[Bronchitis],[[0.93,0.07],[0.2,0.8]])
53 p_wheeze = Prob(Wheezing,[Bronchitis],[[0.999,0.001],[0.4,0.6]])
54
55 simple_diagnosis = BeliefNetwork("Simple Diagnosis",
56     {Influenza, Smokes, SoreThroat, HasFever, Bronchitis,
        Coughing, Wheezing},
57     {p_infl, p_smokes, p_sth, p_fever, p_bronc, p_cough,
        p_wheeze})

```

Sprinkler Example

The third belief network is the sprinkler example from Pearl [2009]. The output of `bn_sprinkler.show()` is shown in Figure 9.4 of this document.

```

_____probExamples.py — (continued)_____
59 Season = Variable("Season", ["dry_season", "wet_season"],
    position=(0.5,0.9))
60 Sprinkler = Variable("Sprinkler", ["on", "off"], position=(0.9,0.6))
61 Rained = Variable("Rained", boolean, position=(0.1,0.6))
62 Grass_wet = Variable("Grass wet", boolean, position=(0.5,0.3))
63 Grass_shiny = Variable("Grass shiny", boolean, position=(0.1,0))
64 Shoes_wet = Variable("Shoes wet", boolean, position=(0.9,0))
65
66 f_season = Prob(Season,[],{'dry_season':0.5, 'wet_season':0.5})
67 f_sprinkler = Prob(Sprinkler,[Season],{'dry_season':{'on':0.4,'off':0.6},
68     'wet_season':{'on':0.01,'off':0.99}})
69 f_rained = Prob(Rained,[Season],{'dry_season':[0.9,0.1], 'wet_season':
    [0.2,0.8]})
70 f_wet = Prob(Grass_wet,[Sprinkler,Rained], {'on': [[0.1,0.9],[0.01,0.99]],
71     'off': [[0.99,0.01],[0.3,0.7]]})
72 f_shiny = Prob(Grass_shiny, [Grass_wet], [[0.95,0.05], [0.3,0.7]])
73 f_shoes = Prob(Shoes_wet, [Grass_wet], [[0.98,0.02], [0.35,0.65]])

```

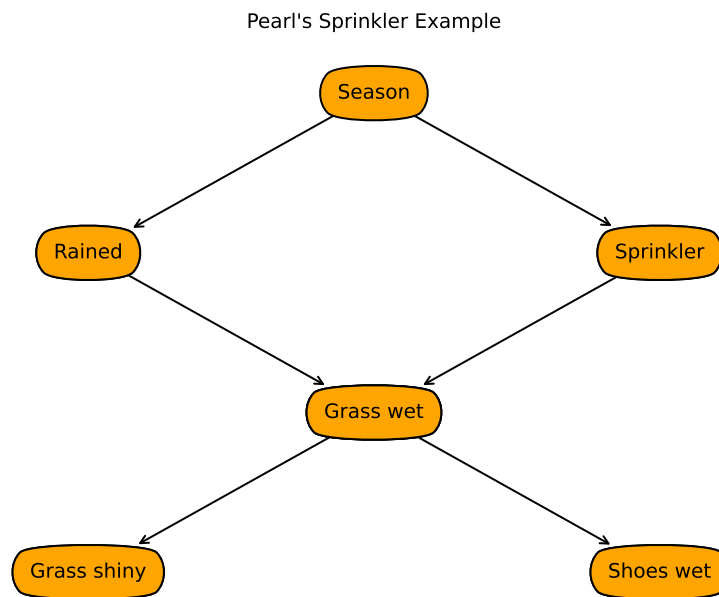

Figure 9.4: The sprinkler belief network

```

74 |
75 | bn_sprinkler = BeliefNetwork("Pearl's Sprinkler Example",
76 |     {Season, Sprinkler, Rained, Grass_wet, Grass_shiny,
77 |     Shoes_wet},
78 |     {f_season, f_sprinkler, f_rained, f_wet, f_shiny,
79 |     f_shoes})

```

Bipartite Diagnostic Model with Noisy-or

The belief network `bn_no1` is a bipartite diagnostic model, with independent diseases, and the symptoms depend on the diseases, where the CPDs are defined using noisy-or. Bipartite means it is in two parts; the diseases are only connected to the symptoms and the symptoms are only connected to the diseases. The output of `bn_no1.show()` is shown in Figure 9.5 of this document.

```

_____probExamples.py — (continued)_____
79 | ##### Bipartite Diagnostic Network #####
80 | Cough = Variable("Cough", boolean, (0.1,0.1))
81 | Fever = Variable("Fever", boolean, (0.5,0.1))
82 | Sneeze = Variable("Sneeze", boolean, (0.9,0.1))
83 | Cold = Variable("Cold",boolean, (0.1,0.9))
84 | Flu = Variable("Flu",boolean, (0.5,0.9))

```

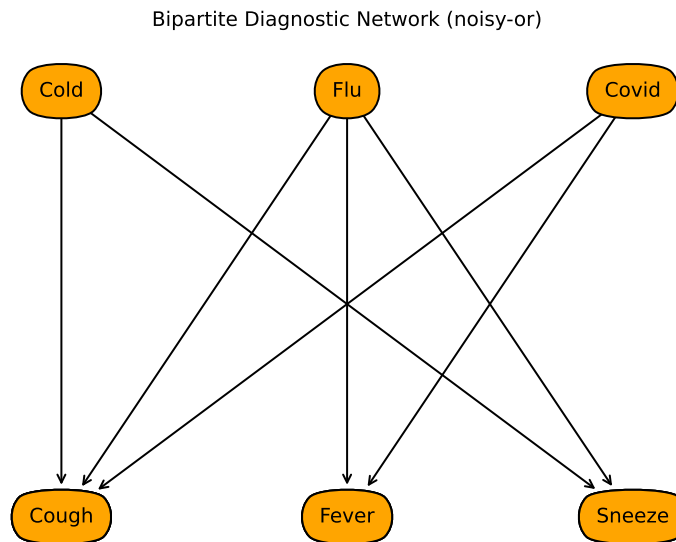

Figure 9.5: A bipartite diagnostic network

```

85 Covid = Variable("Covid",boolean, (0.9,0.9))
86
87 p_cold_no = Prob(Cold,[],[0.9,0.1])
88 p_flu_no = Prob(Flu,[],[0.95,0.05])
89 p_covid_no = Prob(Covid,[],[0.99,0.01])
90
91 p_cough_no = NoisyOR(Cough, [Cold,Flu,Covid], [0.1, 0.3, 0.2, 0.7])
92 p_fever_no = NoisyOR(Fever, [ Flu,Covid], [0.01, 0.6, 0.7])
93 p_sneeze_no = NoisyOR(Sneeze, [Cold,Flu ], [0.05, 0.5, 0.2 ])
94
95 bn_no1 = BeliefNetwork("Bipartite Diagnostic Network (noisy-or)",
96                       {Cough, Fever, Sneeze, Cold, Flu, Covid},
97                       {p_cold_no, p_flu_no, p_covid_no, p_cough_no,
98                        p_fever_no, p_sneeze_no})
99
100 # to see the conditional probability of Noisy-or do:
101 # print(p_cough_no.to_table())
102
103 # example from box "Noisy-or compared to logistic regression"
104 # X = Variable("X",boolean)
105 # w0 = 0.01
106 # print(NoisyOR(X,[A,B,C,D],[w0, 1-(1-0.05)/(1-w0), 1-(1-0.1)/(1-w0),
107                  1-(1-0.2)/(1-w0), 1-(1-0.2)/(1-w0), ]).to_table(given={X:True}))

```

Bipartite Diagnostic Model with Logistic Regression

The belief network `bn_lr1` is a bipartite diagnostic model, with independent diseases, and the symptoms depend on the diseases, where the CPDs are defined using logistic regression. It has the same graphical structure as the previous example (see Figure 9.5). This has the (approximately) the same conditional probabilities as the previous example when zero or one diseases are present. Note that $\text{sigmoid}(-2.2) \approx 0.1$

```

-----probExamples.py --- (continued)-----
107
108 p_cold_lr = Prob(Cold,[],[0.9,0.1])
109 p_flu_lr = Prob(Flu,[],[0.95,0.05])
110 p_covid_lr = Prob(Covid,[],[0.99,0.01])
111
112 p_cough_lr = LogisticRegression(Cough, [Cold,Flu,Covid], [-2.2, 1.67,
113     1.26, 3.19])
114 p_fever_lr = LogisticRegression(Fever, [ Flu,Covid], [-4.6, 5.02,
115     5.46])
116 p_sneeze_lr = LogisticRegression(Sneeze, [Cold,Flu ], [-2.94, 3.04, 1.79
117     ])
118
119 bn_lr1 = BeliefNetwork("Bipartite Diagnostic Network - logistic
120     regression",
121     {Cough, Fever, Sneeze, Cold, Flu, Covid},
122     {p_cold_lr, p_flu_lr, p_covid_lr, p_cough_lr,
123     p_fever_lr, p_sneeze_lr})
124
125 # to see the conditional probability of Noisy-or do:
126 #print(p_cough_lr.to_table())
127
128 # example from box "Noisy-or compared to logistic regression"
129 # from learnLinear import sigmoid, logit
130 # w0=logit(0.01)
131 # X = Variable("X",boolean)
132 # print(LogisticRegression(X,[A,B,C,D],[w0, logit(0.05)-w0, logit(0.1)-w0,
133     logit(0.2)-w0, logit(0.2)-w0]).to_table(given={X:True}))
134 # try to predict what would happen (and then test) if we had
135 # w0=logit(0.01)

```

9.5 Inference Methods

Each of the inference methods implements the query method that computes the posterior probability of a variable given a dictionary of $\{variable : value\}$ observations. The methods are `Displayable` because they implement the `display` method which is text-based unless overridden.

```
-----probGraphicalModels.py --- (continued)-----
```

```

95 from display import Displayable
96
97 class InferenceMethod(Displayable):
98     """The abstract class of graphical model inference methods"""
99     method_name = "unnamed" # each method should have a method name
100
101     def __init__(self, gm=None):
102         self.gm = gm
103
104     def query(self, qvar, obs={}):
105         """returns a {value:prob} dictionary for the query variable"""
106         raise NotImplementedError("InferenceMethod query") # abstract method

```

We use `bn_4ch` as the test case, in particular $P(B \mid D = \text{true})$. This needs an error threshold, particularly for the approximate methods, where the default threshold is much too accurate.

```

_____probGraphicalModels.py — (continued)_____
108     def testIM(self, threshold=0.000000001):
109         solver = self(bn_4ch)
110         res = solver.query(B, {D:True})
111         correct_answer = 0.429632380245
112         assert correct_answer - threshold < res[True] <
113             correct_answer + threshold, \
114                 f"value {res[True]} not in desired range for
115                 {self.method_name}"
116         print(f"Unit test passed for {self.method_name}.")

```

9.5.1 Showing Posterior Distributions

The `show_post` method draws the posterior distribution of all variables. Figure 9.6 shows the result of `bn_reportRC.show_post({Report:True})` when run after loading `probRC.py` (see below).

```

_____probGraphicalModels.py — (continued)_____
116     def show_post(self, obs={}, num_format="{:.3f}", fontsize=10,
117                 facecolor='orange'):
118         """draws the graphical model conditioned on observations obs
119             num_format is number format (allows for more or less precision)
120             fontsize gives size of the text
121             facecolor gives the color of the nodes
122         """
123         plt.ion() # interactive
124         fig, ax = plt.subplots()
125         ax.set_axis_off()
126         ax.set_title(self.gm.title + " observed: " + str(obs),
127                     fontsize=fontsize)
128         self.show_post_graph(fig, ax, obs=obs, num_format=num_format,
129                             fontsize=fontsize, facecolor=facecolor)
129

```

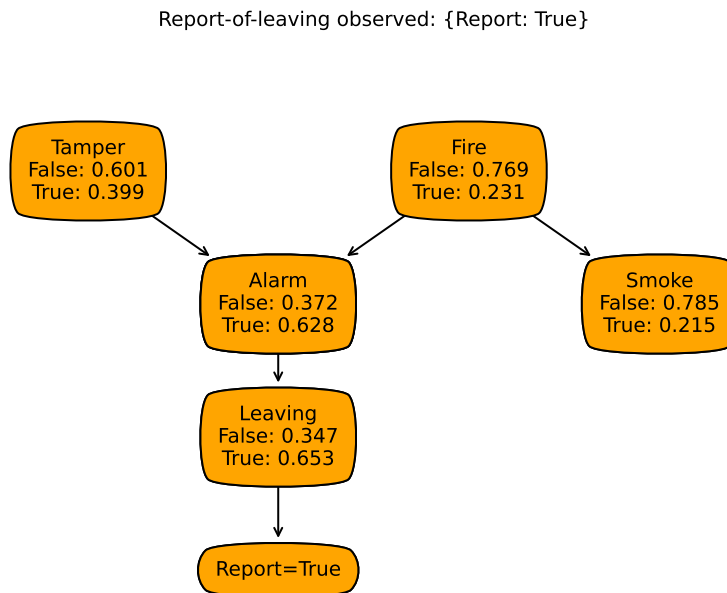

Figure 9.6: The report-of-leaving belief network with posterior distributions

```

128 def show_post_graph(self, fig, ax, obs={}, num_format="{:.3f}",
129     fontsize=10, facecolor='orange'):
130     bbox = dict(boxstyle="round4,pad=1.0,rounding_size=0.5",
131               facecolor=facecolor)
132     vartext = {} # variable:text dictionary
133     self.nodes = {} # node:variable dictionary (used in probGUI)
134     for var in self.gm.variables: #reversed(self.gm.topological_sort()):
135         if var in obs:
136             text = var.name + "=" + str(obs[var])
137         else:
138             distn = self.query(var, obs=obs)
139             text = var.name + "\n" + "\n".join(str(d)+"\n"+num_format.format(v) for (d,v) in distn.items())
140         vartext[var] = text
141     # Draw arcs
142     for par in self.gm.var2parents[var]:
143         ax.annotate(text, par.position, xytext=var.position,
144                   arrowprops={'arrowstyle': '<-'},bbox=bbox,
145                   ha='center', va='center',
146                   fontsize=fontsize)
147     for var in self.gm.variables:
148         x,y = var.position
  
```

```

147         node = ax.text(x,y,vartext[var], bbox=bbox, ha='center',
148                        va='center', fontsize=fontsize)
        self.nodes[node] = var

```

9.6 Naive Search

An instance of a *ProbSearch* object takes in a graphical model. The query method uses naive search to compute the probability of a query variable given observations on other variables. See Figure 9.9 of Poole and Mackworth [2023].

```

_____probRC.py — Search-based Inference for Graphical Models_____
11 import math
12 from probGraphicalModels import GraphicalModel, InferenceMethod
13 from probFactors import Factor
14
15 class ProbSearch(InferenceMethod):
16     """The class that queries graphical models using search
17
18     gm is graphical model to query
19     """
20     method_name = "naive search"
21
22     def __init__(self, gm=None):
23         InferenceMethod.__init__(self, gm)
24         ## self.max_display_level = 3
25
26     def query(self, qvar, obs={}, split_order=None):
27         """computes P(qvar | obs) where
28         qvar is the query variable
29         obs is a variable:value dictionary
30         split_order is a list of the non-observed non-query variables in gm
31         """
32         if qvar in obs:
33             return {val:(1 if val == obs[qvar] else 0)
34                     for val in qvar.domain}
35         else:
36             if split_order == None:
37                 split_order = [v for v in self.gm.variables
38                               if (v not in obs) and v != qvar]
39             unnorm = [self.prob_search({qvar:val}|obs, self.gm.factors,
40                                     split_order)
41                       for val in qvar.domain]
42             p_obs = sum(unnorm)
43             return {val:pr/p_obs for val,pr in zip(qvar.domain, unnorm)}

```

The following is the naive search-based algorithm. It is exponential in the number of variables, so is not very useful. However, it is simple, and helpful to understand before looking at the more complicated algorithm used in the subclass.

```

probRC.py — (continued)
44 def prob_search(self, context, factors, split_order):
45     """simple search algorithm
46     context: a variable:value dictionary
47     factors: a set of factors
48     split_order: list of variables not assigned in context
49     returns sum over variable assignments to variables in split order
50     of product of factors """
51     self.display(2, "calling prob_search,", (context, factors, split_order))
52     if not factors:
53         return 1
54     elif to_eval := {fac for fac in factors
55                     if fac.can_evaluate(context)}:
56         # evaluate factors when all variables are assigned
57         self.display(3, "prob_search evaluating factors", to_eval)
58         val = math.prod(fac.get_value(context) for fac in to_eval)
59         return val * self.prob_search(context, factors-to_eval,
60                                     split_order)
61     else:
62         total = 0
63         var = split_order[0]
64         self.display(3, "prob_search branching on", var)
65         for val in var.domain:
66             total += self.prob_search({var:val}|context, factors,
67                                     split_order[1:])
68         self.display(3, "prob_search branching on", var, "returning",
69                     total)
70     return total

```

9.7 Recursive Conditioning

The **recursive conditioning (RC)** algorithm adds forgetting and caching and recognizing disconnected components to the naive search. We do this by adding a cache and redefining the recursive search algorithm. It inherits the query method. See Figure 9.12 of Poole and Mackworth [2023].

The cache is initialized with the empty context and empty factors has probability 1. This means that checking the cache can act as the base case when the context is empty.

```

probRC.py — (continued)
68 class ProbRC(ProbSearch):
69     method_name = "recursive conditioning"
70
71     def __init__(self, gm=None):
72         self.cache = {(frozenset(), frozenset()):1}
73         ProbSearch.__init__(self, gm)
74
75     def prob_search(self, context, factors, split_order):

```

```

76     """ returns sum_{split_order} prod_{factors} given assignment in
77     context
78     context is a variable:value dictionary
79     factors is a set of factors
80     split_order: list of variables in factors that are not in context
81     """
82     self.display(3,"calling rc",(context,factors))
83     ce = (frozenset(context.items()), frozenset(factors)) # key for the
84     cache entry
85     if ce in self.cache:
86         self.display(3,"rc cache lookup",(context,factors))
87         return self.cache[ce]
88     elif vars_not_in_factors := {var for var in context
89                                 if not any(var in fac.variables
90                                           for fac in factors)}:
91         # forget variables not in any factor
92         self.display(3,"rc forgetting variables", vars_not_in_factors)
93         return self.prob_search({key:val for (key,val) in
94                                 context.items()
95                                 if key not in vars_not_in_factors},
96                                 factors, split_order)
97     elif to_eval := {fac for fac in factors
98                     if fac.can_evaluate(context)}:
99         # evaluate factors when all variables are assigned
100        self.display(3,"rc evaluating factors",to_eval)
101        val = math.prod(fac.get_value(context) for fac in to_eval)
102        if val == 0:
103            return 0
104        else:
105            return val * self.prob_search(context,
106                                        {fac for fac in factors
107                                          if fac not in to_eval},
108                                        split_order)
109    elif len(comp := connected_components(context, factors,
110                                        split_order)) > 1:
111        # there are disconnected components
112        self.display(3,"splitting into connected components",comp,"in
113        context",context)
114        return(math.prod(self.prob_search(context,f,eo) for (f,eo) in
115                        comp))
116    else:
117        assert split_order, "split_order should not be empty to get
118        here"
119        total = 0
120        var = split_order[0]
121        self.display(3, "rc branching on", var)
122        for val in var.domain:
123            total += self.prob_search({var:val}|context, factors,
124                                    split_order[1:])
125        self.cache[ce] = total

```

```

118         self.display(2, "rc branching on", var,"returning", total)
119         return total

```

`connected_components` returns a list of connected components, where a connected component is a set of factors and a set of variables, where the graph that connects variables and factors that involve them is connected. The connected components are built one at a time; with a current connected component. At all times factors is partitioned into 3 disjoint sets:

- `component_factors` containing factors in the current connected component where all factors that share a variable are already in the component
- `factors_to_check` containing factors in the current connected component where potentially some factors that share a variable are not in the component; these need to be checked
- `other_factors` the other factors that are not (yet) in the connected component

```

_____probRC.py — (continued)_____
121 def connected_components(context, factors, split_order):
122     """returns a list of (f,e) where f is a subset of factors and e is a
123     subset of split_order
124     such that each element shares the same variables that are disjoint from
125     other elements.
126     """
127     other_factors = set(factors) #copies factors
128     factors_to_check = {other_factors.pop()} # factors in connected
129     component still to be checked
130     component_factors = set() # factors in first connected component
131     already checked
132     component_variables = set() # variables in first connected component
133     while factors_to_check:
134         next_fac = factors_to_check.pop()
135         component_factors.add(next_fac)
136         new_vars = set(next_fac.variables) - component_variables -
137         context.keys()
138         component_variables |= new_vars
139         for var in new_vars:
140             factors_to_check |= {f for f in other_factors
141                                 if var in f.variables}
142             other_factors -= factors_to_check # set difference
143     if other_factors:
144         return ( [(component_factors,[e for e in split_order
145                     if e in component_variables])]
146                 + connected_components(context, other_factors,
147                                       [e for e in split_order
148                                         if e not in component_variables]) )
149     else:
150         return [(component_factors, split_order)]

```

Testing:

```

probRC.py — (continued)
147 from probGraphicalModels import bn_4ch, A,B,C,D,f_a,f_b,f_c,f_d
148 bn_4chv = ProbRC(bn_4ch)
149 ## bn_4chv.query(A, {})
150 ## bn_4chv.query(D, {})
151 ## InferenceMethod.max_display_level = 3 # show more detail in displaying
152 ## InferenceMethod.max_display_level = 1 # show less detail in displaying
153 ## bn_4chv.query(A, {D:True}, [C,B])
154 ## bn_4chv.query(B, {A:True,D:False})
155
156 from probExamples import bn_report, Alarm, Fire, Leaving, Report, Smoke, Tamper
157 bn_reportRC = ProbRC(bn_report) # answers queries using recursive
    conditioning
158 ## bn_reportRC.query(Tamper, {})
159 ## InferenceMethod.max_display_level = 0 # show no detail in displaying
160 ## bn_reportRC.query(Leaving, {})
161 ## bn_reportRC.query(Tamper, {},
    split_order=[Smoke, Fire, Alarm, Leaving, Report])
162 ## bn_reportRC.query(Tamper, {Report:True})
163 ## bn_reportRC.query(Tamper, {Report:True, Smoke:False})
164
165 ## To display resulting posteriors try:
166 # bn_reportRC.show_post({})
167 # bn_reportRC.show_post({Smoke:False})
168 # bn_reportRC.show_post({Report:True})
169 # bn_reportRC.show_post({Report:True, Smoke:False})
170
171 ## Note what happens to the cache when these are called in turn:
172 ## bn_reportRC.query(Tamper, {Report:True},
    split_order=[Smoke, Fire, Alarm, Leaving])
173 ## bn_reportRC.query(Smoke, {Report:True},
    split_order=[Tamper, Fire, Alarm, Leaving])
174
175 from probExamples import bn_sprinkler, Season, Sprinkler, Rained,
    Grass_wet, Grass_shiny, Shoes_wet
176 bn_sprinklerv = ProbRC(bn_sprinkler)
177 ## bn_sprinklerv.query(Shoes_wet, {})
178 ## bn_sprinklerv.query(Shoes_wet, {Rained:True})
179 ## bn_sprinklerv.query(Shoes_wet, {Grass_shiny:True})
180 ## bn_sprinklerv.query(Shoes_wet, {Grass_shiny:False, Rained:True})
181
182 from probExamples import bn_no1, bn_lr1, Cough, Fever, Sneeze, Cold, Flu,
    Covid
183 bn_no1v = ProbRC(bn_no1)
184 bn_lr1v = ProbRC(bn_lr1)
185 ## bn_no1v.query(Flu, {Fever:1, Sneeze:1})
186 ## bn_lr1v.query(Flu, {Fever:1, Sneeze:1})
187 ## bn_lr1v.query(Cough, {})
188 ## bn_lr1v.query(Cold, {Cough:1, Sneeze:0, Fever:1})

```

```

189 ## bn_lr1v.query(Flu,{Cough:0,Sneeze:1,Fever:1})
190 ## bn_lr1v.query(Covid,{Cough:1,Sneeze:0,Fever:1})
191 ## bn_lr1v.query(Covid,{Cough:1,Sneeze:0,Fever:1,Flu:0})
192 ## bn_lr1v.query(Covid,{Cough:1,Sneeze:0,Fever:1,Flu:1})
193
194 if __name__ == "__main__":
195     InferenceMethod.testIM(ProbSearch)
196     InferenceMethod.testIM(ProbRC)

```

The following example uses the decision tree representation of Section 9.3.4 (page 234).

```

_____probRC.py — (continued)_____
198 from probFactors import Prob, action, rain, full, wet, p_wet
199 from probGraphicalModels import BeliefNetwork
200 p_action = Prob(action,[],{'go_out':0.3, 'get_coffee':0.7})
201 p_rain = Prob(rain,[],[0.4,0.6])
202 p_full = Prob(full,[],[0.1,0.9])
203
204 wetBN = BeliefNetwork("Wet (decision tree CPD)", {action, rain, full, wet},
205                 {p_action, p_rain, p_full, p_wet})
206 wetRC = ProbRC(wetBN)
207 # wetRC.query(wet, {action:'go_out', rain:True})
208 # wetRC.show_post({action:'go_out', rain:True})
209 # wetRC.show_post({action:'go_out', wet:True})

```

Exercise 9.1 Does recursive conditioning split on variable `full` for the query commented out above? Does it need to? Fix the code so that decision tree representations of conditional probabilities can be evaluated as soon as possible.

Exercise 9.2 This code adds to the cache only after splitting. Implement a variant that caches after forgetting. (What can the cache start with?) Which version works better? Compare some measure of the search tree and the space used. Try other alternatives of what to cache; which method works best?

9.8 Variable Elimination

An instance of a *VE* object takes in a graphical model. The query method uses variable elimination to compute the probability of a variable given observations on some other variables.

```

_____probVE.py — Variable Elimination for Graphical Models_____
11 from probFactors import Factor, FactorObserved, FactorSum, factor_times
12 from probGraphicalModels import GraphicalModel, InferenceMethod
13
14 class VE(InferenceMethod):
15     """The class that queries Graphical Models using variable elimination.
16
17     gm is graphical model to query
18     """

```

```

19 |     method_name = "variable elimination"
20 |
21 |     def __init__(self, gm=None):
22 |         InferenceMethod.__init__(self, gm)
23 |
24 |     def query(self, var, obs={}, elim_order=None):
25 |         """computes P(var|obs) where
26 |         var is a variable
27 |         obs is a {variable:value} dictionary"""
28 |         if var in obs:
29 |             return {var:1 if val == obs[var] else 0 for val in var.domain}
30 |         else:
31 |             if elim_order == None:
32 |                 elim_order = self.gm.variables
33 |             projFactors = [self.project_observations(fact, obs)
34 |                             for fact in self.gm.factors]
35 |             for v in elim_order:
36 |                 if v != var and v not in obs:
37 |                     projFactors = self.eliminate_var(projFactors, v)
38 |             unnorm = factor_times(var, projFactors)
39 |             p_obs = sum(unnorm)
40 |             self.display(1, "Unnormalized probs:", unnorm, "Prob obs:", p_obs)
41 |             return {val:pr/p_obs for val, pr in zip(var.domain, unnorm)}

```

A *FactorObserved* is a factor that is the result of some observations on another factor. We don't store the values in a list; we just look them up as needed. The observations can include variables that are not in the list, but should have some intersection with the variables in the factor.

```

_____probFactors.py — (continued)_____
237 | class FactorObserved(Factor):
238 |     def __init__(self, factor, obs):
239 |         Factor.__init__(self, [v for v in factor.variables if v not in obs])
240 |         self.observed = obs
241 |         self.orig_factor = factor
242 |
243 |     def get_value(self, assignment):
244 |         return self.orig_factor.get_value(assignment|self.observed)

```

A *FactorSum* is a factor that is the result of summing out a variable from the product of other factors. I.e., it constructs a representation of:

$$\sum_{var} \prod_{f \in factors} f(var).$$

We store the values in a list in a lazy manner; if they are already computed, we used the stored values. If they are not already computed we can compute and store them.

```

_____probFactors.py — (continued)_____
246 | class FactorSum(Factor):

```

```

247 def __init__(self, var, factors):
248     self.var_summed_out = var
249     self.factors = factors
250     vars = list({v for fac in factors
251                 for v in fac.variables if v is not var})
252     #for fac in factors:
253     #    for v in fac.variables:
254     #        if v is not var and v not in vars:
255     #            vars.append(v)
256     Factor.__init__(self, vars)
257     self.values = {}
258
259 def get_value(self, assignment):
260     """lazy implementation: if not saved, compute it. Return saved
261     value"""
262     asst = frozenset(assignment.items())
263     if asst in self.values:
264         return self.values[asst]
265     else:
266         total = 0
267         new_asst = assignment.copy()
268         for val in self.var_summed_out.domain:
269             new_asst[self.var_summed_out] = val
270             total += math.prod(fac.get_value(new_asst) for fac in
271                               self.factors)
272         self.values[asst] = total
273         return total

```

The method *factor_times* multiplies a set of factors that are all factors on the same variable (or on no variables). This is the last step in variable elimination before normalizing. It returns an array giving the product for each value of *variable*.

```

_____probFactors.py — (continued)_____
273 def factor_times(variable, factors):
274     """when factors are factors just on variable (or on no variables)"""
275     prods = []
276     facs = [f for f in factors if variable in f.variables]
277     for val in variable.domain:
278         ast = {variable:val}
279         prods.append(math.prod(f.get_value(ast) for f in facs))
280     return prods

```

To project observations onto a factor, for each variable that is observed in the factor, we construct a new factor that is the factor projected onto that variable. *Factor_observed* creates a new factor that is the result is assigning a value to a single variable.

```

_____probVE.py — (continued)_____
43 def project_observations(self, factor, obs):
44     """Returns the resulting factor after observing obs

```

```

45     obs is a dictionary of {variable:value} pairs.
46     """
47
48     if any((var in obs) for var in factor.variables):
49         # a variable in factor is observed
50         return FactorObserved(factor,obs)
51     else:
52         return factor
53
54 def eliminate_var(self,factors,var):
55     """Eliminate a variable var from a list of factors.
56     Returns a new set of factors that has var summed out.
57     """
58     self.display(2,"eliminating ",str(var))
59     contains_var = []
60     not_contains_var = []
61     for fac in factors:
62         if var in fac.variables:
63             contains_var.append(fac)
64         else:
65             not_contains_var.append(fac)
66     if contains_var == []:
67         return factors
68     else:
69         newFactor = FactorSum(var,contains_var)
70         self.display(2,"Multiplying:",[str(f) for f in contains_var])
71         self.display(2,"Creating factor:", newFactor)
72         self.display(3, newFactor.to_table()) # factor in detail
73         not_contains_var.append(newFactor)
74     return not_contains_var
75
76 from probGraphicalModels import bn_4ch, A,B,C,D
77 bn_4chv = VE(bn_4ch)
78 ## bn_4chv.query(A,{})
79 ## bn_4chv.query(D,{})
80 ## InferenceMethod.max_display_level = 3 # show more detail in displaying
81 ## InferenceMethod.max_display_level = 1 # show less detail in displaying
82 ## bn_4chv.query(A,{D:True})
83 ## bn_4chv.query(B,{A:True,D:False})
84
85 from probExamples import bn_report,Alarm,Fire,Leaving,Report,Smoke,Tamper
86 bn_reportv = VE(bn_report) # answers queries using variable elimination
87 ## bn_reportv.query(Tamper,{})
88 ## InferenceMethod.max_display_level = 0 # show no detail in displaying
89 ## bn_reportv.query(Leaving,{})
90 ## bn_reportv.query(Tamper,{},elim_order=[Smoke,Report,Leaving,Alarm,Fire])
91 ## bn_reportv.query(Tamper,{Report:True})
92 ## bn_reportv.query(Tamper,{Report:True,Smoke:False})
93
94 from probExamples import bn_sprinkler, Season, Sprinkler, Rained,

```

```

    Grass_wet, Grass_shiny, Shoes_wet
95 bn_sprinklerv = VE(bn_sprinkler)
96 ## bn_sprinklerv.query(Shoes_wet,{})
97 ## bn_sprinklerv.query(Shoes_wet,{Rained:True})
98 ## bn_sprinklerv.query(Shoes_wet,{Grass_shiny:True})
99 ## bn_sprinklerv.query(Shoes_wet,{Grass_shiny:False,Rained:True})
100
101 from probExamples import bn_lr1, Cough, Fever, Sneeze, Cold, Flu, Covid
102 vediag = VE(bn_lr1)
103 ## vediag.query(Cough,{})
104 ## vediag.query(Cold,{Cough:1,Sneeze:0,Fever:1})
105 ## vediag.query(Flu,{Cough:0,Sneeze:1,Fever:1})
106 ## vediag.query(Covid,{Cough:1,Sneeze:0,Fever:1})
107 ## vediag.query(Covid,{Cough:1,Sneeze:0,Fever:1,Flu:0})
108 ## vediag.query(Covid,{Cough:1,Sneeze:0,Fever:1,Flu:1})
109
110 if __name__ == "__main__":
111     InferenceMethod.testIM(VE)

```

9.9 Stochastic Simulation

9.9.1 Sampling from a discrete distribution

The method *sample_one* generates a single sample from a (possibly unnormalized) distribution. *dist* is a $\{value : weight\}$ dictionary, where $weight \geq 0$. This returns a value with probability in proportion to its weight.

```

_____probStochSim.py — Probabilistic inference using stochastic simulation _____
11 import random
12 from probGraphicalModels import InferenceMethod
13
14 def sample_one(dist):
15     """returns the index of a single sample from normalized distribution
16     dist."""
17     rand = random.random()*sum(dist.values())
18     cum = 0 # cumulative weights
19     for v in dist:
20         cum += dist[v]
21         if cum > rand:
22             return v

```

If we want to generate multiple samples, repeatedly calling *sample_one* may not be efficient. If we want to generate multiple samples, and the distribution is over m values, it searches through the m values of the distribution for each sample.

The method *sample_multiple* generates multiple samples from a distribution defined by *dist*, where *dist* is a $\{value : weight\}$ dictionary, where $weight \geq 0$ and

the weights are not all zero. This returns a list of values, of length *num_samples*, where each sample is selected with a probability proportional to its weight.

The method generates all of the random numbers, sorts them, and then goes through the distribution once, saving the selected samples.

```

_____probStochSim.py — (continued)_____
23 def sample_multiple(dist, num_samples):
24     """returns a list of num_samples values selected using distribution
        dist.
25     dist is a {value:weight} dictionary that does not need to be normalized
26     """
27     total = sum(dist.values())
28     rands = sorted(random.random()*total for i in range(num_samples))
29     result = []
30     dist_items = list(dist.items())
31     cum = dist_items[0][1] # cumulative sum
32     index = 0
33     for r in rands:
34         while r>cum:
35             index += 1
36             cum += dist_items[index][1]
37         result.append(dist_items[index][0])
38     return result

```

Exercise 9.3

What is the time and space complexity of the following 4 methods to generate *n* samples, where *m* is the length of *dist*:

- n* calls to *sample_one*
- sample_multiple*
- Create the cumulative distribution (choose how this is represented) and, for each random number, do a binary search to determine the sample associated with the random number.
- Choose a random number in the range $[i/n, (i + 1)/n)$ for each $i \in \text{range}(n)$, where *n* is the number of samples. Use these as the random numbers to select the particles. (Does this give random samples?)

For each method suggest when it might be the best method.

The *test_sampling* method can be used to generate the statistics from a number of samples. It is useful to see the variability as a function of the number of samples. Try it for a few samples and also for many samples.

```

_____probStochSim.py — (continued)_____
40 def test_sampling(dist, num_samples):
41     """Given a distribution, dist, draw num_samples samples
42     and return the resulting counts
43     """
44     result = {v:0 for v in dist}
45     for v in sample_multiple(dist, num_samples):

```

```

46     result[v] += 1
47     return result
48
49 # try the following queries a number of times each:
50 # test_sampling({1:1,2:2,3:3,4:4}, 100)
51 # test_sampling({1:1,2:2,3:3,4:4}, 100000)

```

9.9.2 Sampling Methods for Belief Network Inference

A *SamplingInferenceMethod* is an *InferenceMethod*, but the query method also takes arguments for the number of samples and the sample-order (which is an ordering of factors). The first methods assume a belief network (and not an undirected graphical model).

```

_____probStochSim.py — (continued)_____
53 class SamplingInferenceMethod(InferenceMethod):
54     """The abstract class of sampling-based belief network inference
55         methods"""
56
57     def __init__(self, gm=None):
58         InferenceMethod.__init__(self, gm)
59
60     def query(self, qvar, obs={}, number_samples=1000, sample_order=None):
61         raise NotImplementedError("SamplingInferenceMethod query") #
62         abstract

```

9.9.3 Rejection Sampling

```

_____probStochSim.py — (continued)_____
62 class RejectionSampling(SamplingInferenceMethod):
63     """The class that queries Graphical Models using Rejection Sampling.
64
65     gm is a belief network to query
66     """
67     method_name = "rejection sampling"
68
69     def __init__(self, gm=None):
70         SamplingInferenceMethod.__init__(self, gm)
71
72     def query(self, qvar, obs={}, number_samples=1000, sample_order=None):
73         """computes P(qvar | obs) where
74         qvar is a variable.
75         obs is a {variable:value} dictionary.
76         sample_order is a list of variables where the parents
77         come before the variable.
78         """
79         if sample_order is None:
80             sample_order = self.gm.topological_sort()

```

```

81     self.display(2,*sample_order,sep="\t")
82     counts = {val:0 for val in qvar.domain}
83     for i in range(number_samples):
84         rejected = False
85         sample = {}
86         for nvar in sample_order:
87             fac = self.gm.var2cpt[nvar] #factor with nvar as child
88             val = sample_one({v:fac.get_value(**sample, nvar:v)} for v
89                             in nvar.domain})
89             self.display(2,val,end="\t")
90             if nvar in obs and obs[nvar] != val:
91                 rejected = True
92                 self.display(2,"Rejected")
93                 break
94             sample[nvar] = val
95         if not rejected:
96             counts[sample[qvar]] += 1
97             self.display(2,"Accepted")
98     tot = sum(counts.values())
99     # As well as the distribution we also include raw counts
100    dist = {c:v/tot if tot>0 else 1/len(qvar.domain) for (c,v) in
101            counts.items()}
101    dist["raw_counts"] = counts
102    return dist

```

9.9.4 Likelihood Weighting

Likelihood weighting includes a weight for each sample. Instead of rejecting samples based on observations, likelihood weighting changes the weights of the sample in proportion with the probability of the observation. The weight then becomes the probability that the variable would have been rejected.

probStochSim.py — (continued)

```

104 class LikelihoodWeighting(SamplingInferenceMethod):
105     """The class that queries Graphical Models using Likelihood weighting.
106
107     gm is a belief network to query
108     """
109     method_name = "likelihood weighting"
110
111     def __init__(self, gm=None):
112         SamplingInferenceMethod.__init__(self, gm)
113
114     def query(self,qvar,obs={},number_samples=1000,sample_order=None):
115         """computes P(qvar | obs) where
116         qvar is a variable.
117         obs is a {variable:value} dictionary.
118         sample_order is a list of factors where factors defining the parents
119         come before the factors for the child.
120         """
121         if sample_order is None:

```

```

122         sample_order = self.gm.topological_sort()
123     self.display(2,*[v for v in sample_order
124                    if v not in obs],sep="\t")
125     counts = {val:0 for val in qvar.domain}
126     for i in range(number_samples):
127         sample = {}
128         weight = 1.0
129         for nvar in sample_order:
130             fac = self.gm.var2cpt[nvar]
131             if nvar in obs:
132                 sample[nvar] = obs[nvar]
133                 weight *= fac.get_value(sample)
134             else:
135                 val = sample_one({v:fac.get_value(**sample,nvar:v)} for
136                                v in nvar.domain)
137                 self.display(2,val,end="\t")
138                 sample[nvar] = val
139             counts[sample[qvar]] += weight
140         self.display(2,weight)
141     tot = sum(counts.values())
142     # as well as the distribution we also include the raw counts
143     dist = {c:v/tot for (c,v) in counts.items()}
144     dist["raw_counts"] = counts
145     return dist

```

Exercise 9.4 Change this algorithm so that it does **importance sampling** using a proposal distribution that may be different from the prior. It needs *sample_one* using a different distribution and then adjust the weight of the current sample. For testing, use a proposal distribution that only differs from the prior for a subset of the variables. For which variables does the different proposal distribution make the most difference?

9.9.5 Particle Filtering

In this implementation, a particle is a $\{variable : value\}$ dictionary. Because adding a new value to dictionary involves a side effect, the dictionaries are copied during resampling.

```

_____probStochSim.py — (continued)_____
146 class ParticleFiltering(SamplingInferenceMethod):
147     """The class that queries Graphical Models using Particle Filtering.
148
149     gm is a belief network to query
150     """
151     method_name = "particle filtering"
152
153     def __init__(self, gm=None):
154         SamplingInferenceMethod.__init__(self, gm)
155
156     def query(self, qvar, obs={}, number_samples=1000, sample_order=None):

```

```

157     """computes P(qvar | obs) where
158     qvar is a variable.
159     obs is a {variable:value} dictionary.
160     sample_order is a list of factors where factors defining the parents
161     come before the factors for the child.
162     """
163     if sample_order is None:
164         sample_order = self.gm.topological_sort()
165     self.display(2,*[v for v in sample_order
166                    if v not in obs],sep="\t")
167     particles = [{i} for i in range(number_samples)]
168     for nvar in sample_order:
169         fac = self.gm.var2cpt[nvar]
170         if nvar in obs:
171             weights = [fac.get_value(**part, nvar:obs[nvar])]
172             for part in particles]
173             particles = [{**p, nvar:obs[nvar]}
174                          for p in resample(particles, weights,
175                                             number_samples)]
176         else:
177             for part in particles:
178                 part[nvar] = sample_one({v:fac.get_value(**part,
179                                                         nvar:v)}
180                                         for v in nvar.domain))
181             self.display(2,part[nvar],end="\t")
182     counts = {val:0 for val in qvar.domain}
183     for part in particles:
184         counts[part[qvar]] += 1
185     tot = sum(counts.values())
186     # as well as the distribution we also include the raw counts
187     dist = {c:v/tot for (c,v) in counts.items()}
188     dist["raw_counts"] = counts
189     return dist

```

Resampling

Resample is based on *sample_multiple* but works with an array of particles. (Aside: Python doesn't let us use *sample_multiple* directly as it uses a dictionary and particles, represented as dictionaries can't be the key of dictionaries).

probStochSim.py — (continued)

```

189 def resample(particles, weights, num_samples):
190     """returns num_samples copies of particles resampled according to
191     weights.
192     particles is a list of particles
193     weights is a list of positive numbers, of same length as particles
194     num_samples is n integer
195     """
196     total = sum(weights)
197     rands = sorted(random.random()*total for i in range(num_samples))

```

```

197     result = []
198     cum = weights[0] # cumulative sum
199     index = 0
200     for r in rands:
201         while r>cum:
202             index += 1
203             cum += weights[index]
204             result.append(particles[index])
205     return result

```

9.9.6 Examples

```

_____probStochSim.py — (continued)_____
207 from probGraphicalModels import bn_4ch, A,B,C,D
208 bn_4chr = RejectionSampling(bn_4ch)
209 bn_4chL = LikelihoodWeighting(bn_4ch)
210 ## InferenceMethod.max_display_level = 2 # detailed tracing for all
    inference methods
211 ## bn_4chr.query(A,{})
212 ## bn_4chr.query(C,{})
213 ## bn_4chr.query(A,{C:True})
214 ## bn_4chr.query(B,{A:True,C:False})
215
216 from probExamples import bn_report,Alarm,Fire,Leaving,Report,Smoke,Tamper
217 bn_reportr = RejectionSampling(bn_report) # answers queries using
    rejection sampling
218 bn_reportL = LikelihoodWeighting(bn_report) # answers queries using
    likelihood weighting
219 bn_reportp = ParticleFiltering(bn_report) # answers queries using particle
    filtering
220 ## bn_reportr.query(Tamper,{})
221 ## bn_reportr.query(Tamper,{})
222 ## bn_reportr.query(Tamper,{Report:True})
223 ## InferenceMethod.max_display_level = 0 # no detailed tracing for all
    inference methods
224 ## bn_reportr.query(Tamper,{Report:True},number_samples=100000)
225 ## bn_reportr.query(Tamper,{Report:True,Smoke:False})
226 ## bn_reportr.query(Tamper,{Report:True,Smoke:False},number_samples=100)
227
228 ## bn_reportL.query(Tamper,{Report:True,Smoke:False},number_samples=100)
229 ## bn_reportL.query(Tamper,{Report:True,Smoke:False},number_samples=100)
230
231 from probExamples import bn_sprinkler,Season, Sprinkler
232 from probExamples import Rained, Grass_wet, Grass_shiny, Shoes_wet
233 bn_sprinklerr = RejectionSampling(bn_sprinkler) # answers queries using
    rejection sampling
234 bn_sprinklerL = LikelihoodWeighting(bn_sprinkler) # answers queries using
    rejection sampling

```

```

235 bn_sprinklerp = ParticleFiltering(bn_sprinkler) # answers queries using
      particle filtering
236 #bn_sprinklerr.query(Shoes_wet,{Grass_shiny:True,Rained:True})
237 #bn_sprinklerL.query(Shoes_wet,{Grass_shiny:True,Rained:True})
238 #bn_sprinklerp.query(Shoes_wet,{Grass_shiny:True,Rained:True})
239
240 if __name__ == "__main__":
241     InferenceMethod.testIM(RejectionSampling, threshold=0.1)
242     InferenceMethod.testIM(LikelihoodWeighting, threshold=0.1)
243     InferenceMethod.testIM(ParticleFiltering, threshold=0.1)

```

9.9.7 Gibbs Sampling

The following implements **Gibbs sampling**, a form of **Markov Chain Monte Carlo** MCMC.

```

_____probStochSim.py — (continued)_____
245 #import random
246 #from probGraphicalModels import InferenceMethod
247
248 #from probStochSim import sample_one, SamplingInferenceMethod
249
250 class GibbsSampling(SamplingInferenceMethod):
251     """The class that queries Graphical Models using Gibbs Sampling.
252
253     bn is a graphical model (e.g., a belief network) to query
254     """
255     method_name = "Gibbs sampling"
256
257     def __init__(self, gm=None):
258         SamplingInferenceMethod.__init__(self, gm)
259         self.gm = gm
260
261     def query(self, qvar, obs={}, number_samples=1000, burn_in=100,
262              sample_order=None):
263         """computes P(qvar | obs) where
264         qvar is a variable.
265         obs is a {variable:value} dictionary.
266         sample_order is a list of non-observed variables in order, or
267         if sample_order None, an arbitrary ordering is used
268         """
269         counts = {val:0 for val in qvar.domain}
270         if sample_order is not None:
271             variables = sample_order
272         else:
273             variables = [v for v in self.gm.variables if v not in obs]
274             random.shuffle(variables)
275         var_to_factors = {v:set() for v in self.gm.variables}
276         for fac in self.gm.factors:
277             for var in fac.variables:
278                 var_to_factors[var].add(fac)

```

```

278     sample = {var:random.choice(var.domain) for var in variables}
279     self.display(3,"Sample:",sample)
280     sample.update(obs)
281     for i in range(burn_in + number_samples):
282         for var in variables:
283             # get unnormalized probability distribution of var given its
                neighbors
284             vardist = {val:1 for val in var.domain}
285             for val in var.domain:
286                 sample[var] = val
287                 for fac in var_to_factors[var]: # Markov blanket
288                     vardist[val] *= fac.get_value(sample)
289             sample[var] = sample_one(vardist)
290         if i >= burn_in:
291             counts[sample[qvar]] +=1
292             self.display(3,"      ",sample)
293         tot = sum(counts.values())
294         # as well as the computed distribution, we also include raw counts
295         dist = {c:v/tot for (c,v) in counts.items()}
296         dist["raw_counts"] = counts
297         self.display(2, f"Gibbs sampling P({qvar}|{obs}) = {dist}")
298         return dist
299
300 #from probGraphicalModels import bn_4ch, A,B,C,D
301 bn_4chg = GibbsSampling(bn_4ch)
302 ## InferenceMethod.max_display_level = 2 # detailed tracing for all
        inference methods
303 bn_4chg.query(A,{})
304 ## bn_4chg.query(D,{})
305 ## bn_4chg.query(B,{D:True})
306 ## bn_4chg.query(B,{A:True,C:False})
307
308 from probExamples import bn_report,Alarm,Fire,Leaving,Report,Smoke,Tamper
309 bn_reportg = GibbsSampling(bn_report)
310 ## bn_reportg.query(Tamper,{Report:True},number_samples=1000)
311
312 if __name__ == "__main__":
313     InferenceMethod.testIM(GibbsSampling, threshold=0.1)

```

Exercise 9.5 Change the code so that it can have multiple query variables. Make the list of query variable be an input to the algorithm, so that the default value is the list of all non-observed variables.

Exercise 9.6 In this algorithm, explain where it computes the probability of a variable given its Markov blanket. Instead of returning the average of the samples for the query variable, it is possible to return the average estimate of the probability of the query variable given its Markov blanket. Does this converge to the same answer as the given code? Does it converge faster, slower, or the same?

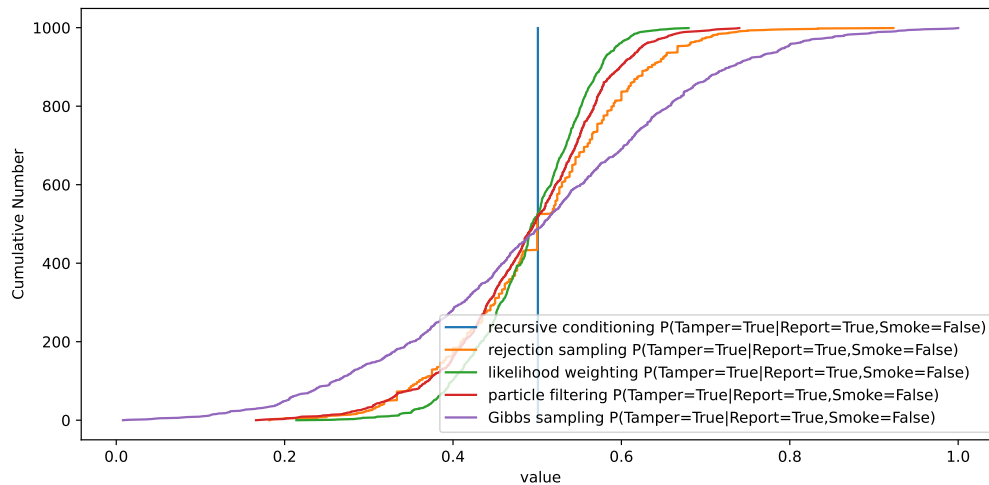

Figure 9.7: Cumulative distribution of the prediction of various models for $P(\text{Tamper}=\text{True} \mid \text{report} \wedge \neg \text{smoke})$

9.9.8 Plotting Behavior of Stochastic Simulators

The stochastic simulation runs can give different answers each time they are run. For the algorithms that give the same answer in the limit as the number of samples approaches infinity (as do all of these algorithms), the algorithms can be compared by comparing the accuracy for multiple runs. Summary statistics like the variance may provide some information, but the assumptions behind the variance being appropriate (namely that the distribution is approximately Gaussian) may not hold for cases where the predictions are bounded and often skewed.

It is more appropriate to plot the distribution of predictions over multiple runs. The `plot_stats` method plots the prediction of a particular variable (or for the partition function) for a number of runs of the same algorithm. On the x -axis, is the prediction of the algorithm. On the y -axis is the number of runs with prediction less than or equal to the x value. Thus this is like a cumulative distribution over the predictions, but with counts on the y -axis.

Note that for runs where there are no samples that are consistent with the observations (as can happen with rejection sampling), the prediction of probability is 1.0 (as a convention for 0/0).

That variable `what` contains the query variable, or if `what` is `"prob_ev"`, the probability of evidence.

Figure 9.7 shows the distribution of various models. This figure is generated using the first `plot_mult` example below. Recursive conditioning gives the exact answer, and so is a vertical line. The others provide the cumulative prediction for 1000 runs for each method. This graph shows that for this graph and query, likelihood weighting is closest to the exact answer.

```

315 import matplotlib.pyplot as plt
316
317 def plot_stats(method, qvar, qval, obs, number_runs=1000, **queryargs):
318     """Plots a cumulative distribution of the prediction of the model.
319     method is a InferenceMethod (that implements appropriate query())
320     plots P(qvar=qval | obs)
321     qvar is the query variable, qval is corresponding value
322     obs is the {variable:value} dictionary representing the observations
323     number_iterations is the number of runs that are plotted
324     **queryargs is the arguments to query (often number_samples for
325         sampling methods)
326     """
327     plt.ion()
328     # ax is global
329     ax.set_xlabel("value")
330     ax.set_ylabel("Cumulative Number")
331     method.max_display_level, prev_mdl = 0, method.max_display_level #no
332     display
333     answers = [method.query(qvar, obs, **queryargs)
334               for i in range(number_runs)]
335     values = [ans[qval] for ans in answers]
336     label = f"""{method.method_name}
337             P({qvar}={qval}|{' ,'.join(f'{var}={val}'
338                                     for (var, val) in
339                                     obs.items())}"""
340     values.sort()
341     ax.plot(values, range(number_runs), label=label)
342     ax.legend() #loc="upper left")
343     plt.show()
344     method.max_display_level = prev_mdl # restore display level
345
346 if __name__ == "__main__":
347     fig, ax = plt.subplots()
348
349 # Try:
350 # plot_stats(bn_reportr, Tamper, True, {Report: True, Smoke: True},
351 #           number_samples=1000, number_runs=1000)
352 # plot_stats(bn_reportL, Tamper, True, {Report: True, Smoke: True},
353 #           number_samples=1000, number_runs=1000)
354 # plot_stats(bn_reportp, Tamper, True, {Report: True, Smoke: True},
355 #           number_samples=1000, number_runs=1000)
356 # plot_stats(bn_reportr, Tamper, True, {Report: True, Smoke: True},
357 #           number_samples=100, number_runs=1000)
358 # plot_stats(bn_reportL, Tamper, True, {Report: True, Smoke: True},
359 #           number_samples=100, number_runs=1000)
360 # plot_stats(bn_reportg, Tamper, True, {Report: True, Smoke: True},
361 #           number_samples=1000, number_runs=1000)
362
363 def plot_mult(methods, example, qvar, qval, obs, number_samples=1000,

```

```

    number_runs=1000):
354     for method in methods:
355         solver = method(example)
356         if isinstance(method, SamplingInferenceMethod):
357             plot_stats(solver, qvar, qval, obs,
                        number_samples=number_samples, number_runs=number_runs)
358         else:
359             plot_stats(solver, qvar, qval, obs, number_runs=number_runs)
360
361     from probRC import ProbRC
362     # Try following (but it takes a while..)
363     methods = [ProbRC, RejectionSampling, LikelihoodWeighting,
                ParticleFiltering, GibbsSampling]
364     #plot_mult(methods, bn_report, Tamper, True, {Report: True, Smoke: False},
                number_samples=100, number_runs=1000)
365     # plot_mult(methods, bn_report, Tamper, True, {Report: False, Smoke: True},
                number_samples=100, number_runs=1000)
366
367     # Sprinkler Example:
368     # plot_stats(bn_sprinklerr, Shoes_wet, True, {Grass_shiny: True, Rained: True},
                number_samples=1000)
369     # plot_stats(bn_sprinklerL, Shoes_wet, True, {Grass_shiny: True, Rained: True},
                number_samples=1000)

```

9.10 Hidden Markov Models

This code for hidden Markov models (HMMs) is independent of the graphical models code, to keep it simple. Section 9.11 gives code that models hidden Markov models, and more generally, dynamic belief networks, using the graphical models code.

This HMM code assumes there are multiple Boolean observation variables that depend on the current state and are independent of each other given the state.

```

_____probHMM.py — Hidden Markov Model_____
11 import random
12 from probStochSim import sample_one, sample_multiple
13
14 class HMM(object):
15     def __init__(self, states, obsvars, pobs, trans, indist):
16         """A hidden Markov model.
17         states - set of states
18         obsvars - set of observation variables
19         pobs - probability of observations, pobs[i][s] is P(Obs_i=True |
                State=s)
20         trans - transition probability - trans[i][j] gives P(State=j |
                State=i)
21         indist - initial distribution - indist[s] is P(State_0 = s)

```

```

22     """
23     self.states = states
24     self.obsvars = obsvars
25     self.pobs = pobs
26     self.trans = trans
27     self.indist = indist

```

Consider the following example. Suppose you want to unobtrusively keep track of an animal in a triangular enclosure using sound. Suppose you have 3 microphones that provide unreliable (noisy) binary information at each time step. The animal is either close to one of the 3 points of the triangle or in the middle of the triangle.

```

-----probHMM.py --- (continued)-----
29 # state
30 #     0=middle, 1,2,3 are corners
31 states1 = {'middle', 'c1', 'c2', 'c3'} # states
32 obs1 = {'m1', 'm2', 'm3'} # microphones

```

The observation model is as follows. If the animal is in a corner, it will be detected by the microphone at that corner with probability 0.6, and will be independently detected by each of the other microphones with a probability of 0.1. If the animal is in the middle, it will be detected by each microphone with a probability of 0.4.

```

-----probHMM.py --- (continued)-----
34 # pobs gives the observation model:
35 #pobs[mi][state] is P(mi=on | state)
36 closeMic=0.6; farMic=0.1; midMic=0.4
37 pobs1 = {'m1':{'middle':midMic, 'c1':closeMic, 'c2':farMic, 'c3':farMic},
          # mic 1
          'm2':{'middle':midMic, 'c1':farMic, 'c2':closeMic, 'c3':farMic}, #
          mic 2
          'm3':{'middle':midMic, 'c1':farMic, 'c2':farMic, 'c3':closeMic}} #
          mic 3

```

The transition model is as follows: If the animal is in a corner it stays in the same corner with probability 0.80, goes to the middle with probability 0.1 or goes to one of the other corners with probability 0.05 each. If it is in the middle, it stays in the middle with probability 0.7, otherwise it moves to one the corners, each with probability 0.1.

```

-----probHMM.py --- (continued)-----
41 # trans specifies the dynamics
42 # trans[i] is the distribution over states resulting from state i
43 # trans[i][j] gives P(S=j | S=i)
44 sm=0.7; mmc=0.1 # transition probabilities when in middle
45 sc=0.8; mcm=0.1; mcc=0.05 # transition probabilities when in a corner
46 trans1 = {'middle':{'middle':sm, 'c1':mmc, 'c2':mmc, 'c3':mmc}, # was in
          middle

```

```

47     'c1':{'middle':mcm, 'c1':sc, 'c2':mcc, 'c3':mcc}, # was in corner
      1
48     'c2':{'middle':mcm, 'c1':mcc, 'c2':sc, 'c3':mcc}, # was in corner
      2
49     'c3':{'middle':mcm, 'c1':mcc, 'c2':mcc, 'c3':sc}} # was in corner
      3

```

Initially the animal is in one of the four states, with equal probability.

```

_____probHMM.py — (continued)_____
51 # initially we have a uniform distribution over the animal's state
52 indist1 = {st:1.0/len(states1) for st in states1}
53
54 hmm1 = HMM(states1, obs1, pobs1, trans1, indist1)

```

9.10.1 Exact Filtering for HMMs

A *HMMVEfilter* has a current state distribution which can be updated by observing or by advancing to the next time.

```

_____probHMM.py — (continued)_____
56 from display import Displayable
57
58 class HMMVEfilter(Displayable):
59     def __init__(self, hmm):
60         self.hmm = hmm
61         self.state_dist = hmm.indist
62
63     def filter(self, obsseq):
64         """updates and returns the state distribution following the
        sequence of
65         observations in obsseq using variable elimination.
66
67         Note that it first advances time.
68         This is what is required if it is called sequentially.
69         If that is not what is wanted initially, do an observe first.
70         """
71         for obs in obsseq:
72             self.advance() # advance time
73             self.observe(obs) # observe
74         return self.state_dist
75
76     def observe(self, obs):
77         """updates state conditioned on observations.
78         obs is a list of values for each observation variable"""
79         for i in self.hmm.obsvars:
80             self.state_dist = {st:self.state_dist[st]*(self.hmm.pobs[i][st]
81                 if obs[i] else
82                 (1-self.hmm.pobs[i][st]))
83                 for st in self.hmm.states}

```

```

83     norm = sum(self.state_dist.values()) # normalizing constant
84     self.state_dist = {st:self.state_dist[st]/norm for st in
                        self.hmm.states}
85     self.display(2,"After observing",obs,"state
                        distribution:",self.state_dist)
86
87     def advance(self):
88         """advance to the next time"""
89         nextstate = {st:0.0 for st in self.hmm.states} # distribution over
                        next states
90         for j in self.hmm.states: # j ranges over next states
91             for i in self.hmm.states: # i ranges over previous states
92                 nextstate[j] += self.hmm.trans[i][j]*self.state_dist[i]
93         self.state_dist = nextstate
94         self.display(2,"After advancing state
                        distribution:",self.state_dist)

```

The following are some queries for *hmm1*.

```

probHMM.py — (continued)
96 hmm1f1 = HMMVEfilter(hmm1)
97 # hmm1f1.filter([{'m1':0, 'm2':1, 'm3':1}, {'m1':1, 'm2':0, 'm3':1}])
98 ## HMMVEfilter.max_display_level = 2 # show more detail in displaying
99 # hmm1f2 = HMMVEfilter(hmm1)
100 # hmm1f2.filter([{'m1':1, 'm2':0, 'm3':0}, {'m1':0, 'm2':1, 'm3':0},
101                 {'m1':1, 'm2':0, 'm3':0},
102                 {'m1':0, 'm2':0, 'm3':0}, {'m1':0, 'm2':0, 'm3':0},
103                 {'m1':0, 'm2':0, 'm3':0}, {'m1':0, 'm2':0, 'm3':1},
104                 {'m1':0, 'm2':0, 'm3':1},
105                 {'m1':0, 'm2':0, 'm3':1}])
106 # hmm1f3 = HMMVEfilter(hmm1)
107 # hmm1f3.filter([{'m1':1, 'm2':0, 'm3':0}, {'m1':0, 'm2':0, 'm3':0},
108                 {'m1':1, 'm2':0, 'm3':0}, {'m1':1, 'm2':0, 'm3':1}])
109
110 # How do the following differ in the resulting state distribution?
111 # Note they start the same, but have different initial observations.
112 ## HMMVEfilter.max_display_level = 1 # show less detail in displaying
113 # for i in range(100): hmm1f1.advance()
114 # hmm1f1.state_dist
115 # for i in range(100): hmm1f3.advance()
116 # hmm1f3.state_dist

```

Exercise 9.7 The representation assumes that there are a list of Boolean observations. Extend the representation so that the each observation variable can have multiple discrete values. You need to choose a representation for the model, and change the algorithm.

9.10.2 Localization

The localization example in the book is a controlled HMM, where there is a given action at each time and the transition depends on the action.

```

_____probLocalization.py — Controlled HMM and Localization example _____
11 from probHMM import HMMVEfilter, HMM
12 from display import Displayable
13 import matplotlib.pyplot as plt
14 from matplotlib.widgets import Button, CheckButtons
15
16 class HMM_Controlled(HMM):
17     """A controlled HMM, where the transition probability depends on the
18         action.
19         Instead of the transition probability, it has a function act2trans
20         from action to transition probability.
21         Any algorithms need to select the transition probability according
22         to the action.
23     """
24     def __init__(self, states, obsvars, pobs, act2trans, indist):
25         self.act2trans = act2trans
26         HMM.__init__(self, states, obsvars, pobs, None, indist)
27
28 local_states = list(range(16))
29 door_positions = {2,4,7,11}
30 def prob_door(loc): return 0.8 if loc in door_positions else 0.1
31 local_obs = {'door':[prob_door(i) for i in range(16)]}
32 act2trans = {'right': [[0.1 if next == current
33                        else 0.8 if next == (current+1)%16
34                        else 0.074 if next == (current+2)%16
35                        else 0.002 for next in range(16)]
36                  for current in range(16)],
37               'left': [[0.1 if next == current
38                        else 0.8 if next == (current-1)%16
39                        else 0.074 if next == (current-2)%16
40                        else 0.002 for next in range(16)]
41                  for current in range(16)]}
42 hmm_16pos = HMM_Controlled(local_states, {'door'}, local_obs,
                           act2trans, [1/16 for i in range(16)])

```

To change the VE localization code to allow for controlled HMMs, notice that the action selects which transition probability to us.

```

_____probLocalization.py — (continued) _____
43 class HMM_Local(HMMVEfilter):
44     """VE filter for controlled HMMs
45     """
46     def __init__(self, hmm):
47         HMMVEfilter.__init__(self, hmm)
48

```

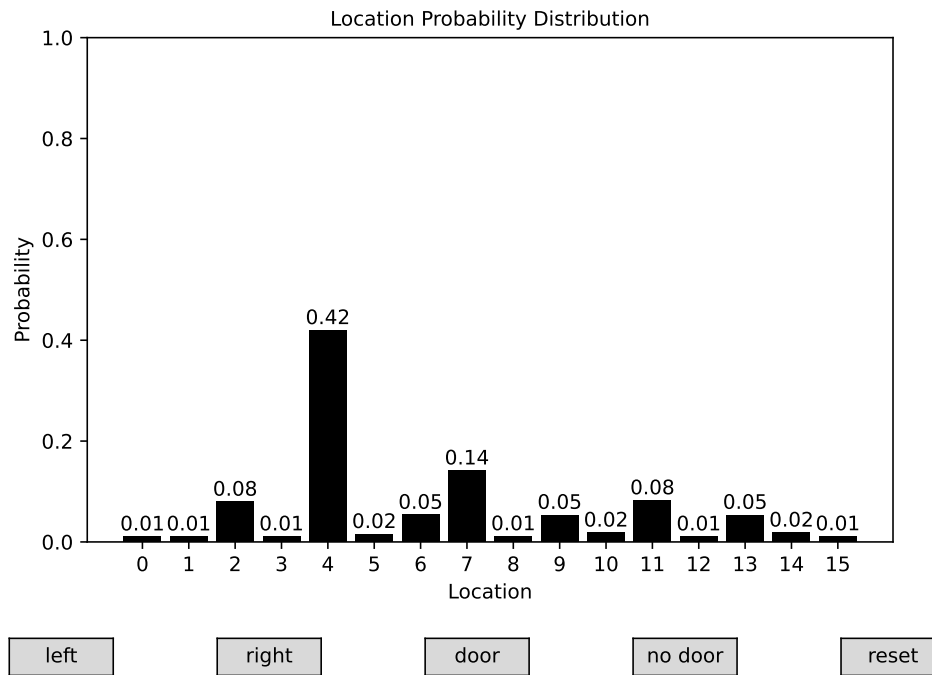

Figure 9.8: Localization GUI after observing a door, moving right, observing no door, moving right, and observing a door.

```

49     def go(self, action):
50         self.hmm.trans = self.hmm.act2trans[action]
51         self.advance()
52
53     loc_filt = HMM_Local(hmm_16pos)
54     # loc_filt.observe({'door':True}); loc_filt.go("right");
55     loc_filt.observe({'door':False}); loc_filt.go("right");
56     loc_filt.observe({'door':True})
57     # loc_filt.state_dist

```

The following lets us interactively move the agent and provide observations. It shows the distribution over locations. Figure 9.8 shows the GUI obtained by `Show_Localization(hmm_16pos)` after some interaction.

```

probLocalization.py — (continued)
57 class Show_Localization(Displayable):
58     def __init__(self, hmm, fontsize=10):
59         self.hmm = hmm
60         self.fontsize = fontsize
61         self.loc_filt = HMM_Local(hmm)
62         fig, self.ax = plt.subplots()
63         fig.subplots_adjust(bottom=0.2)

```

```

64     ## Set up buttons:
65     left_buttn = Button(fig.add_axes([0.05,0.02,0.1,0.05]), "left")
66     left_buttn.label.set_fontsize(self.fontsize)
67     left_buttn.on_clicked(self.left)
68     right_buttn = Button(fig.add_axes([0.25,0.02,0.1,0.05]), "right")
69     right_buttn.label.set_fontsize(self.fontsize)
70     right_buttn.on_clicked(self.right)
71     door_buttn = Button(fig.add_axes([0.45,0.02,0.1,0.05]), "door")
72     door_buttn.label.set_fontsize(self.fontsize)
73     door_buttn.on_clicked(self.door)
74     nodoor_buttn = Button(fig.add_axes([0.65,0.02,0.1,0.05]), "no door")
75     nodoor_buttn.label.set_fontsize(self.fontsize)
76     nodoor_buttn.on_clicked(self.nodoor)
77     reset_buttn = Button(fig.add_axes([0.85,0.02,0.1,0.05]), "reset")
78     reset_buttn.label.set_fontsize(self.fontsize)
79     reset_buttn.on_clicked(self.reset)
80     ## draw the distribution
81     plt.subplot(1, 1, 1)
82     self.draw_dist()
83     plt.show()
84
85     def draw_dist(self):
86         self.ax.clear()
87         self.ax.set_ylim(0,1)
88         self.ax.set_ylabel("Probability", fontsize=self.fontsize)
89         self.ax.set_xlabel("Location", fontsize=self.fontsize)
90         self.ax.set_title("Location Probability Distribution",
91             fontsize=self.fontsize)
92         self.ax.set_xticks(self.hmm.states, labels = self.hmm.states,
93             fontsize=self.fontsize)
94         vals = [self.loc_filt.state_dist[i] for i in self.hmm.states]
95         self.bars = self.ax.bar(self.hmm.states, vals, color='black')
96         self.ax.bar_label(self.bars,["{v:.2f}".format(v=v) for v in vals],
97             padding = 1, fontsize=self.fontsize)
98         plt.draw()
99
100    def left(self,event):
101        self.loc_filt.go("left")
102        self.draw_dist()
103
104    def right(self,event):
105        self.loc_filt.go("right")
106        self.draw_dist()
107
108    def door(self,event):
109        self.loc_filt.observe({'door':True})
110        self.draw_dist()
111
112    def nodoor(self,event):
113        self.loc_filt.observe({'door':False})
114        self.draw_dist()
115
116    def reset(self,event):
117        self.loc_filt.state_dist = {i:1/16 for i in range(16)}

```

```

111     self.draw_dist()
112
113 # Show_Localization(hmm_16pos)
114 # Show_Localization(hmm_16pos, fontsize=15) # for demos - enlarge window
115
116 if __name__ == "__main__":
117     print("Try: Show_Localization(hmm_16pos)")

```

9.10.3 Particle Filtering for HMMs

In this implementation, a particle is just a state. If you want to do some form of smoothing, a particle should probably be a history of states. This maintains, *particles*, an array of states, *weights* an array of (non-negative) real numbers, such that *weights*[*i*] is the weight of *particles*[*i*].

```

_____probHMM.py — (continued)_____
114 from display import Displayable
115 from probStochSim import resample
116
117 class HMMparticleFilter(Displayable):
118     def __init__(self, hmm, number_particles=1000):
119         self.hmm = hmm
120         self.particles = [sample_one(hmm.indist)
121                          for i in range(number_particles)]
122         self.weights = [1 for i in range(number_particles)]
123
124     def filter(self, obsseq):
125         """returns the state distribution following the sequence of
126         observations in obsseq using particle filtering.
127
128         Note that it first advances time.
129         This is what is required if it is called after previous filtering.
130         If that is not what is wanted initially, do an observe first.
131         """
132         for obs in obsseq:
133             self.advance() # advance time
134             self.observe(obs) # observe
135             self.resample_particles()
136             self.display(2, "After observing", str(obs),
137                         "state distribution:",
138                         self.histogram(self.particles))
139             self.display(1, "Final state distribution:",
140                         self.histogram(self.particles))
141         return self.histogram(self.particles)
142
143     def advance(self):
144         """advance to the next time.
145         This assumes that all of the weights are 1."""
146         self.particles = [sample_one(self.hmm.trans[st])

```

```

145         for st in self.particles]
146
147     def observe(self, obs):
148         """reweighs the particles to incorporate observations obs"""
149         for i in range(len(self.particles)):
150             for obv in obs:
151                 if obs[obv]:
152                     self.weights[i] *= self.hmm.pobs[obv][self.particles[i]]
153                 else:
154                     self.weights[i] *=
155                         1-self.hmm.pobs[obv][self.particles[i]]
156
157     def histogram(self, particles):
158         """returns list of the probability of each state as represented by
159         the particles"""
160         tot=0
161         hist = {st: 0.0 for st in self.hmm.states}
162         for (st,wt) in zip(self.particles,self.weights):
163             hist[st]+=wt
164             tot += wt
165         return {st:hist[st]/tot for st in hist}
166
167     def resample_particles(self):
168         """resamples to give a new set of particles."""
169         self.particles = resample(self.particles, self.weights,
170                                 len(self.particles))
171         self.weights = [1] * len(self.particles)

```

The following are some queries for *hmm1*.

```

-----probHMM.py ----- (continued) -----
171 hmm1pf1 = HMMparticleFilter(hmm1)
172 # HMMparticleFilter.max_display_level = 2 # show each step
173 # hmm1pf1.filter([{'m1':0, 'm2':1, 'm3':1}, {'m1':1, 'm2':0, 'm3':1}])
174 # hmm1pf2 = HMMparticleFilter(hmm1)
175 # hmm1pf2.filter([{'m1':1, 'm2':0, 'm3':0}, {'m1':0, 'm2':1, 'm3':0},
176                 {'m1':1, 'm2':0, 'm3':0},
177                 {'m1':0, 'm2':0, 'm3':0}, {'m1':0, 'm2':0, 'm3':0},
178                 {'m1':0, 'm2':0, 'm3':0},
179                 {'m1':0, 'm2':0, 'm3':1},
180                 {'m1':0, 'm2':0, 'm3':1},
181                 {'m1':0, 'm2':0, 'm3':1}])
182 # hmm1pf3 = HMMparticleFilter(hmm1)
183 # hmm1pf3.filter([{'m1':1, 'm2':0, 'm3':0}, {'m1':0, 'm2':0, 'm3':0},
184                 {'m1':1, 'm2':0, 'm3':0}, {'m1':1, 'm2':0, 'm3':1}])

```

Exercise 9.8 A form of importance sampling can be obtained by not resampling. Is it better or worse than particle filtering? Hint: you need to think about how they can be compared. Is the comparison different if there are more states than particles?

Exercise 9.9 Extend the particle filtering code to continuous variables and observations. In particular, suppose the state transition is a linear function with Gaussian noise of the previous state, and the observations are linear functions with Gaussian noise of the state. You may need to research how to sample from a Gaussian distribution (or use Python's random library).

9.10.4 Generating Examples

The following code is useful for generating examples.

```

182 def simulate(hmm,horizon):
183     """returns a pair of (state sequence, observation sequence) of length
        horizon.
184     for each time t, the agent is in state_sequence[t] and
185     observes observation_sequence[t]
186     """
187     state = sample_one(hmm.indist)
188     obsseq=[]
189     stateseq=[]
190     for time in range(horizon):
191         stateseq.append(state)
192         newobs =
            {obs: sample_one({0:1-hmm.pobs[obs][state],1:hmm.pobs[obs][state]})
193             for obs in hmm.obsvars}
194         obsseq.append(newobs)
195         state = sample_one(hmm.trans[state])
196     return stateseq,obsseq
197
198 def simobs(hmm,stateseq):
199     """returns observation sequence for the state sequence"""
200     obsseq=[]
201     for state in stateseq:
202         newobs =
            {obs: sample_one({0:1-hmm.pobs[obs][state],1:hmm.pobs[obs][state]})
203             for obs in hmm.obsvars}
204         obsseq.append(newobs)
205     return obsseq
206
207 def create_eg(hmm,n):
208     """Create an annotated example for horizon n"""
209     seq,obs = simulate(hmm,n)
210     print("True state sequence:",seq)
211     print("Sequence of observations:\n",obs)
212     hmmfilter = HMMVEfilter(hmm)
213     dist = hmmfilter.filter(obs)
214     print("Resulting distribution over states:\n",dist)

```

9.11 Dynamic Belief Networks

A **dynamic belief network (DBN)** is a belief network that extends in time.

There are a number of ways that reasoning can be carried out in a DBN, including:

- Rolling out the DBN for some time period, and using standard belief network inference. The latest time that needs to be in the rolled out network is the time of the latest observation or the time of a query (whichever is later). This allows us to observe any variables at any time and query any variables at any time. This is covered in Section 9.11.2.
- An unrolled belief network may be very large, and we might only be interested in asking about “now”. In this case we can just representing the variables “now”. In this approach we can observe and query the current variables. We can then move to the next time. This does not allow for arbitrary historical queries (about the past or the future), but can be much simpler. This is covered in Section 9.11.3.

9.11.1 Representing Dynamic Belief Networks

To specify a DBN, consider an arbitrary point, *now*, which will be represented as time 1. Each variable will have a corresponding previous variable; the variables and their previous instances will be created together.

A dynamic belief network consists of:

- A set of features. A variable is a feature-time pair.
- An initial distribution over the features “now” (time 1). This is a belief network with all variables being time 1 variables.
- A specification of the dynamics. We define the how the variables *now* (time 1) depend on variables *now* and the previous time (time 0), in such a way that the graph is acyclic.

```

_____probDBN.py — Dynamic belief networks_____
11 from variable import Variable
12 from probGraphicalModels import GraphicalModel, BeliefNetwork
13 from probFactors import Prob, Factor, CPD
14 from probVE import VE
15 from display import Displayable
16
17 class DBNvariable(Variable):
18     """A random variable that incorporates the stage (time)
19
20     A DBN variable has both a name and an index. The index defaults to 1.
21     position is (x,y) where x>0.3
22     """

```

```

23     def __init__(self, name, domain=[False,True], index=1, position=None):
24         Variable.__init__(self, f"{name}_{index}", domain,
25                             position=position)
26         self.basename = name
27         self.domain = domain
28         self.index = index
29         self.previous = None
30
31     def __lt__(self,other):
32         if self.name == other.name:
33             return self.index < other.index
34         else:
35             return self.name < other.name
36
37     def variable_pair(name, domain=[False,True], position=None):
38         """returns a variable and its predecessor. This is used to define
39         2-stage DBNs
40
41         If the name is X, it returns the pair of variables X_prev,X_now"""
42         var_now = DBNvariable(name, domain, index='now', position=position)
43         if position:
44             (x,y) = position
45             position = (x-0.3, y)
46             var_prev = DBNvariable(name, domain, index='prev', position=position)
47             var_now.previous = var_prev
48         return var_prev, var_now

```

A *FactorRename* is a factor that is the result of renaming the variables in the factor. It takes a factor, *fac*, and a $\{new : old\}$ dictionary, where *new* is the name of a variable in the resulting factor and *old* is the corresponding name in *fac*. This assumes that all variables are renamed.

probDBN.py — (continued)

```

48 class FactorRename(Factor):
49     def __init__(self, fac, renaming):
50         """A renamed factor.
51         fac is a factor
52         renaming is a dictionary of the form {new:old} where old and new
53         var variables,
54         where the variables in fac appear exactly once in the renaming
55         """
56         Factor.__init__(self,[n for (n,o) in renaming.items() if o in
57                             fac.variables])
58         self.orig_fac = fac
59         self.renaming = renaming
60
61     def get_value(self, assignment):
62         return self.orig_fac.get_value({self.renaming[var]:val
63                                         for (var,val) in assignment.items()
64                                         if var in self.variables})

```

The following class renames the variables of a conditional probability distribution. It is used for template models (e.g., dynamic decision networks or relational models)

```

_____probDBN.py — (continued)_____
64 class CPDrename(FactorRename, CPD):
65     def __init__(self, cpd, renaming):
66         renaming_inverse = {old:new for (new,old) in renaming.items()}
67         CPD.__init__(self,renaming_inverse[cpd.child],[renaming_inverse[p]
           for p in cpd.parents])
68         self.orig_fac = cpd
69         self.renaming = renaming

```

```

_____probDBN.py — (continued)_____
71 class DBN(Displayable):
72     """The class of stationary Dynamic Belief networks.
73     * name is the DBN name
74     * vars_now is a list of current variables (each must have
75     previous variable).
76     * transition_factors is a list of factors for P(X|parents) where X
77     is a current variable and parents is a list of current or previous
       variables.
78     * init_factors is a list of factors for P(X|parents) where X is a
79     current variable and parents can only include current variables
80     The graph of transition factors + init factors must be acyclic.
81
82     """
83     def __init__(self, title, vars_now, transition_factors=None,
           init_factors=None):
84         self.title = title
85         self.vars_now = vars_now
86         self.vars_prev = [v.previous for v in vars_now]
87         self.transition_factors = transition_factors
88         self.init_factors = init_factors
89         self.var_index = {} # var_index[v] is the index of variable v
90         for i,v in enumerate(vars_now):
91             self.var_index[v]=i
92
93     def show(self):
94         BNfromDBN(self,1).show()

```

Here is a 3 variable DBN (shown in Figure 9.9):

```

_____probDBN.py — (continued)_____
96 A0,A1 = variable_pair("A", domain=[False,True], position = (0.4,0.8))
97 B0,B1 = variable_pair("B", domain=[False,True], position = (0.4,0.5))
98 C0,C1 = variable_pair("C", domain=[False,True], position = (0.4,0.2))
99
100 # dynamics
101 pc = Prob(C1,[B1,C0],[[[0.03,0.97],[0.38,0.62]],[[0.23,0.77],[0.78,0.22]]])
102 pb = Prob(B1,[A0,A1],[[[0.5,0.5],[0.77,0.23]],[[0.4,0.6],[0.83,0.17]]])

```

Simple DBN

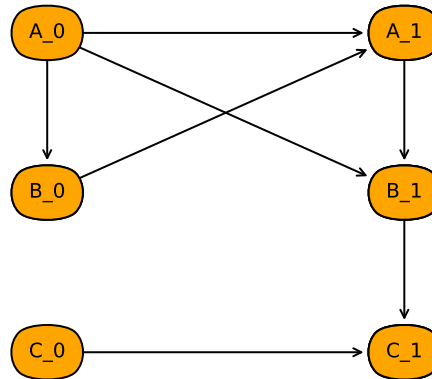

Figure 9.9: Simple dynamic belief network (dbn1.show())

```

103 pa = Prob(A1,[A0,B0],[[0.1,0.9],[0.65,0.35]],[[0.3,0.7],[0.8,0.2]])
104
105 # initial distribution
106 pa0 = Prob(A1,[],[0.9,0.1])
107 pb0 = Prob(B1,[A1],[[0.3,0.7],[0.8,0.2]])
108 pc0 = Prob(C1,[],[0.2,0.8])
109
110 dbn1 = DBN("Simple DBN",[A1,B1,C1],[pa,pb,pc],[pa0,pb0,pc0])

```

Here is the animal example

```

-----probDBN.py --- (continued)-----
112 from probHMM import closeMic, farMic, midMic, sm, mmc, sc, mcm, mcc
113
114 Pos_0,Pos_1 = variable_pair("Position", domain=[0,1,2,3],
115                             position=(0.5,0.8))
115 Mic1_0,Mic1_1 = variable_pair("Mic1", position=(0.6,0.6))
116 Mic2_0,Mic2_1 = variable_pair("Mic2", position=(0.6,0.4))
117 Mic3_0,Mic3_1 = variable_pair("Mic3", position=(0.6,0.2))
118
119 # conditional probabilities - see hmm for the values of sm,mmc, etc
120 ppos = Prob(Pos_1, [Pos_0],
121             [[sm, mmc, mmc, mmc], #was in middle
122              [mcm, sc, mcc, mcc], #was in corner 1
123              [mcm, mcc, sc, mcc], #was in corner 2
124              [mcm, mcc, mcc, sc]]) #was in corner 3
125 pm1 = Prob(Mic1_1, [Pos_1], [[1-midMic, midMic], [1-closeMic, closeMic],
126                               [1-farMic, farMic], [1-farMic, farMic]])
127 pm2 = Prob(Mic2_1, [Pos_1], [[1-midMic, midMic], [1-farMic, farMic],
128                               [1-closeMic, closeMic], [1-farMic, farMic]])
129 pm3 = Prob(Mic3_1, [Pos_1], [[1-midMic, midMic], [1-farMic, farMic],

```

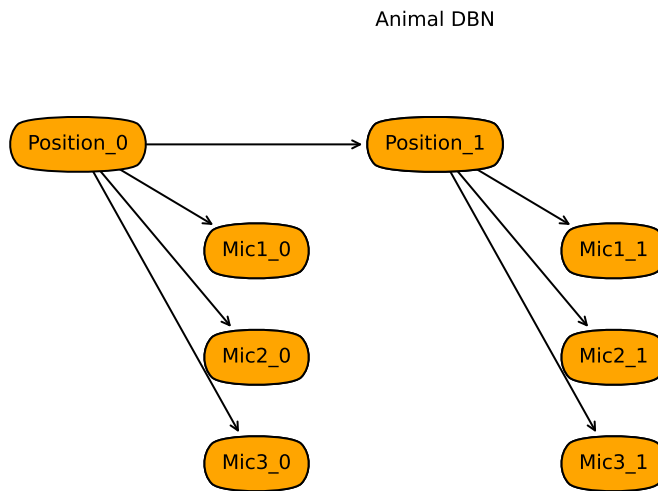
Figure 9.10: Animal dynamic belief network (`dbn_an.show()`)

```

130         [1-farMic, farMic], [1-closeMic, closeMic]])
131 ipos = Prob(Pos_1,[], [0.25, 0.25, 0.25, 0.25])
132 dbn_an =DBN("Animal DBN",[Pos_1,Mic1_1,Mic2_1,Mic3_1],
133           [ppos, pm1, pm2, pm3],
134           [ipos, pm1, pm2, pm3])

```

9.11.2 Unrolling DBNs

```

_____probDBN.py — (continued)_____
136 class BNfromDBN(BeliefNetwork):
137     """Belief Network unrolled from a dynamic belief network
138     """
139
140     def __init__(self,dbn,horizon):
141         """dbn is the dynamic belief network being unrolled
142         horizon>0 is the number of steps (so there will be horizon+1
           variables for each DBN variable.
143         """
144         self.dbn = dbn
145         self.horizon = horizon
146         self.minx,self.width = None, None # for positions pf variables
147         self.name2var = {var.basename:
           [DBNvariable(var.basename,var.domain,index,

```

```

148         position=self.pos(var,index))
149         for index in range(horizon+1)]
150         for var in dbn.vars_now}
151     self.display(1,f"name2var={self.name2var}")
152     variables = {v for vs in self.name2var.values() for v in vs}
153     self.display(1,f"variables={variables}")
154     bnfactors = {CPDrename(fac,{self.name2var[var.basename][0]:var
155                        for var in fac.variables})
156                for fac in dbn.init_factors}
157     bnfactors |= {CPDrename(fac,{self.name2var[var.basename][i]:var
158                        for var in fac.variables if
159                           var.index=='prev'}
160                  | {self.name2var[var.basename][i+1]:var
161                     for var in fac.variables if
162                       var.index=='now'})
163                for fac in dbn.transition_factors
164                  for i in range(horizon)}
165     self.display(1,f"bnfactors={bnfactors}")
166     BeliefNetwork.__init__(self, dbn.title, variables, bnfactors)
167
168     def pos(self, var, index):
169         minx = min(x for (x,y) in (var.position for var in
170                                self.dbn.vars_now))-1e-6
171         maxx = max(x for (x,y) in (var.position for var in
172                                   self.dbn.vars_now))
173         width = maxx-minx
174         xo,yo = var.position
175         xi = index/(self.horizon+1)+(xo-minx)/width/(self.horizon+1)/2
176         return (xi, yo)

```

Here are two examples. You use `bn.name2var['B'][2]` to get the variable B2 (B at time 2). Figure 9.11 shows the output of the `drc.show_post` below:

```

probDBN.py — (continued)
174 # Try
175 from probRC import ProbRC
176 # bn = BNfromDBN(dbn1,2) # construct belief network
177 # drc = ProbRC(bn) # initialize recursive conditioning
178 # B2 = bn.name2var['B'][2]
179 # drc.query(B2) #P(B2)
180 #
181     drc.query(bn.name2var['B'][1],{bn.name2var['B'][0]:True,bn.name2var['C'][1]:False})
182     #P(B1|b0,~c1)
183 # drc.show_post({bn.name2var['B'][0]:True,bn.name2var['C'][1]:False})
184
185 # Plot Distributions:
186 # bna = BNfromDBN(dbn_an,5) # animal belief network with horizon 5
187 # dra = ProbRC(bna)
188 # dra.show_post(obs =
189     {bna.name2var['Mic1'][1]:True,bna.name2var['Mic1'][2]:True})

```

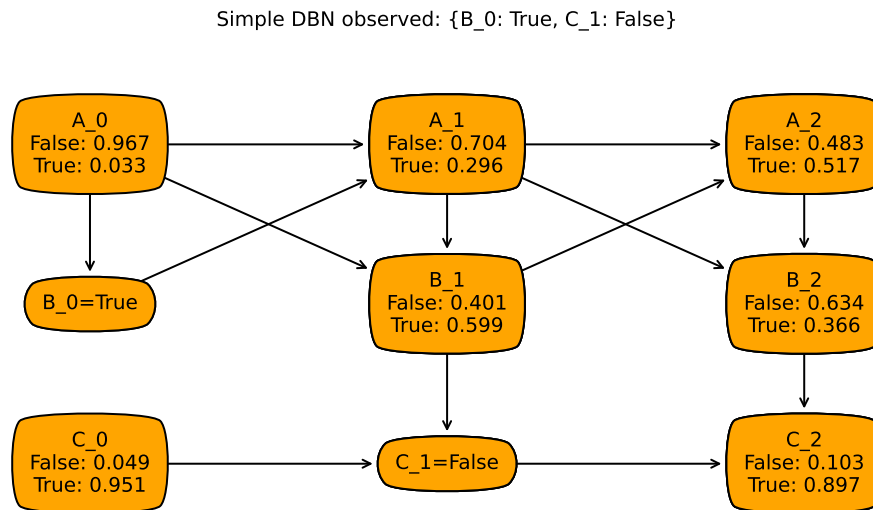

Figure 9.11: Simple dynamic belief network (dbn1) horizon 2

9.11.3 DBN Filtering

If we only wanted to ask questions about the current state, we can save space by forgetting the history variables.

```

_____probDBN.py — (continued) _____
188 class DBNVEfilter(VE):
189     def __init__(self,dbn):
190         self.dbn = dbn
191         self.current_factors = dbn.init_factors
192         self.current_obs = {}
193
194     def observe(self, obs):
195         """updates the current observations with obs.
196         obs is a variable:value dictionary where variable is a current
197         variable.
198         """
199         assert all(self.current_obs[var]==obs[var] for var in obs
200                   if var in self.current_obs),"inconsistent current
201                   observations"
202         self.current_obs.update(obs) # note 'update' is a dict method
203
204     def query(self,var):
205         """returns the posterior probability of current variable var"""

```

```

205     return
206         VE(GraphicalModel(self.dbn.title,self.dbn.vars_now,self.current_factors)
207             ).query(var,self.current_obs)
208
209     def advance(self):
210         """advance to the next time"""
211         prev_factors = [self.make_previous(fac) for fac in
212             self.current_factors]
213         prev_obs = {var.previous:val for var,val in
214             self.current_obs.items()}
215         two_stage_factors = prev_factors + self.dbn.transition_factors
216         self.current_factors =
217             self.elim_vars(two_stage_factors,self.dbn.vars_prev,prev_obs)
218         self.current_obs = {}
219
220     def make_previous(self,fac):
221         """Creates new factor from fac where the current variables in fac
222         are renamed to previous variables.
223         """
224         return FactorRename(fac, {var.previous:var for var in
225             fac.variables})
226
227     def elim_vars(self,factors, vars, obs):
228         for var in vars:
229             if var in obs:
230                 factors = [self.project_observations(fac,obs) for fac in
231                     factors]
232             else:
233                 factors = self.eliminate_var(factors, var)
234         return factors

```

Example queries:

```

-----probDBN.py --- (continued) -----
230 #df = DBNVEfilter(dbn1)
231 #df.observe({B1:True}); df.advance(); df.observe({C1:False})
232 #df.query(B1) #P(B1|B0,C1)
233 #df.advance(); df.query(B1)
234 #dfa = DBNVEfilter(dbn_an)
235 # dfa.observe({Mic1_1:0, Mic2_1:1, Mic3_1:1})
236 # dfa.advance()
237 # dfa.observe({Mic1_1:1, Mic2_1:0, Mic3_1:1})
238 # dfa.query(Pos_1)

```

Learning with Uncertainty

10.1 Bayesian Learning

The section contains two implementations of the (discretized) beta distribution. The first represents Bayesian learning as a belief network. The second is an interactive tool to understand the beta distribution.

The following uses a belief network representation from the previous chapter to learn (discretized) probabilities. Figure 10.1 shows the output after observing *heads, heads, tails*. Notice the prediction of future tosses.

```
learnBayesian.py — Bayesian Learning
11 from variable import Variable
12 from probFactors import Prob
13 from probGraphicalModels import BeliefNetwork
14 from probRC import ProbRC
15
16 ##### Coin Toss ###
17 # multiple coin tosses:
18 toss = ['tails', 'heads']
19 tosses = [ Variable(f"Toss#{i}", toss,
20                 (0.8, 0.9-i/10) if i<10 else (0.4,0.2))
21           for i in range(11)]
22
23 def coinTossBN(num_bins = 10):
24     prob_bins = [x/num_bins for x in range(num_bins+1)]
25     PH = Variable("P_heads", prob_bins, (0.1,0.9))
26     p_PH = Prob(PH,[],{x:0.5/num_bins if x in [0,1] else 1/num_bins for x
27                 in prob_bins})
28     p_tosses = [ Prob(tosses[i],[PH], {x: {'tails':1-x, 'heads':x} for x in
29                 prob_bins})
30                 for i in range(11)]
```

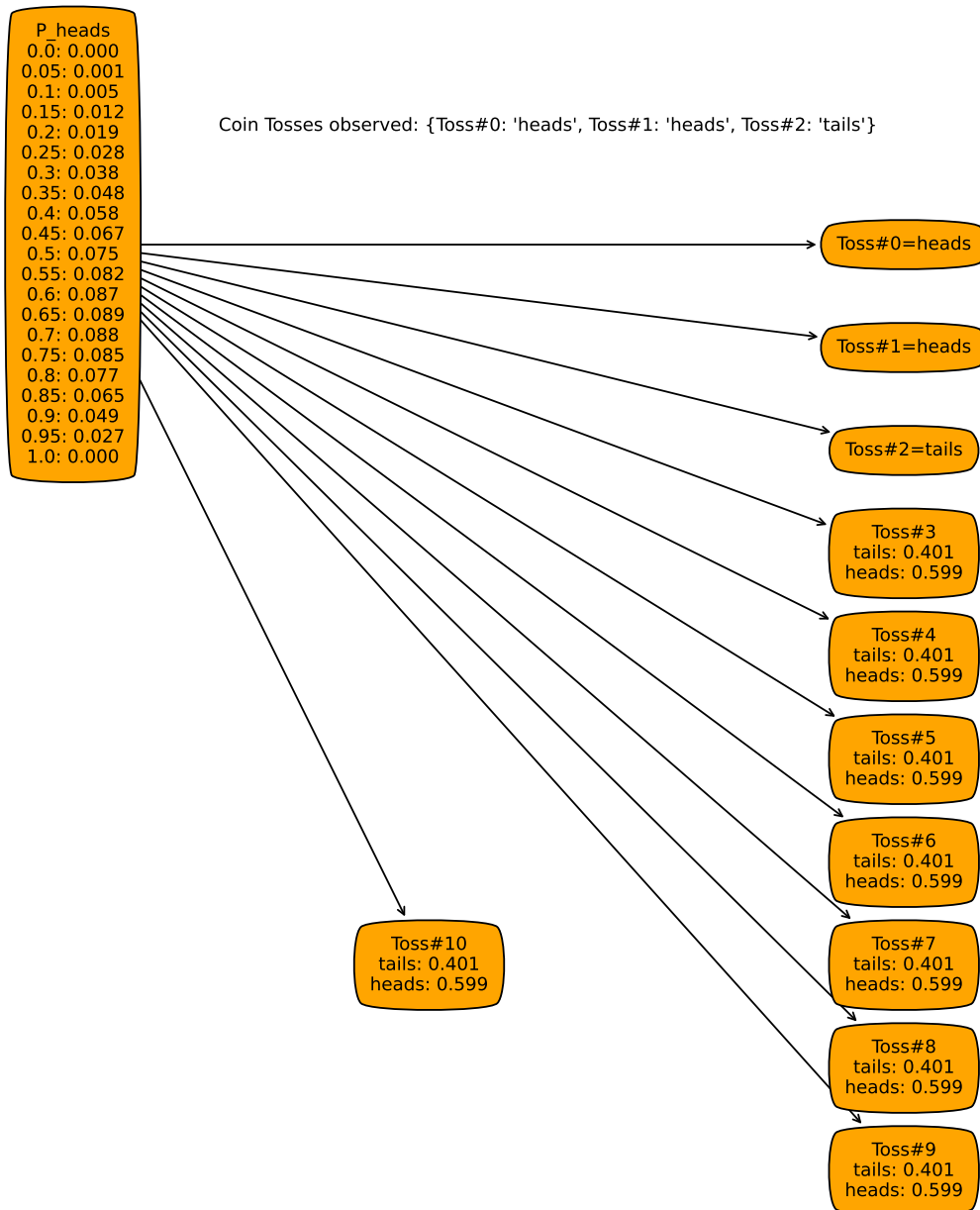

Figure 10.1: coinTossBN after observing heads, heads, tails

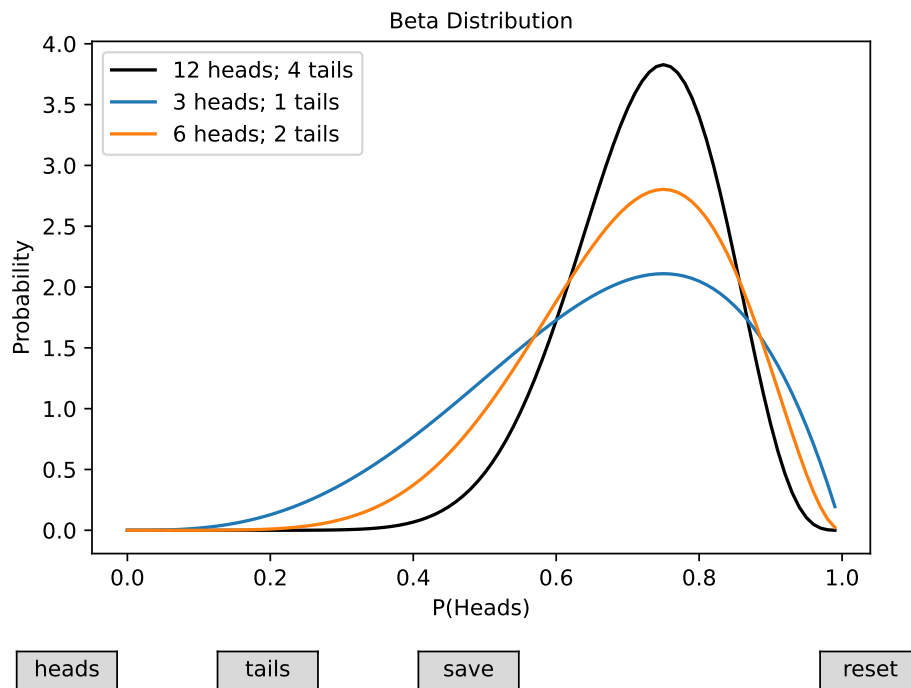

Figure 10.2: Beta distribution after some observations

```

29     return BeliefNetwork("Coin Tosses",
30                           [PH]+tosses,
31                           [p_PH]+p_tosses)
32
33
34 #
35 # coinRC = ProbRC(coinTossBN(20))
36 # coinRC.query(tosses[10],{tosses[0]: 'heads'})
37 # coinRC.show_post({})
38 # coinRC.show_post({tosses[0]: 'heads'})
39 # coinRC.show_post({tosses[0]: 'heads', tosses[1]: 'heads'})
40 # coinRC.show_post({tosses[0]: 'heads', tosses[1]: 'heads', tosses[2]: 'tails'})

```

Figure 10.2 shows a plot of the Beta distribution (the P_{head} variable in the previous belief network) given some sets of observations.

This is a plot that is produced by the following interactive tool.

```

learnBayesian.py — (continued)
42 from display import Displayable
43 import matplotlib.pyplot as plt
44 from matplotlib.widgets import Button, CheckButtons
45
46 class Show_Beta(Displayable):

```

```

47 def __init__(self,num=100, fontsize=10):
48     self.num = num
49     self.dist = [1 for i in range(num)]
50     self.vals = [i/num for i in range(num)]
51     self.fontsize = fontsize
52     self.saves = []
53     self.num_heads = 0
54     self.num_tails = 0
55     plt.ioff()
56     fig, self.ax = plt.subplots()
57     plt.subplots_adjust(bottom=0.2)
58     ## Set up buttons:
59     heads_butt = Button(fig.add_axes([0.05,0.02,0.1,0.05]), "heads")
60     heads_butt.label.set_fontsize(self.fontsize)
61     heads_butt.on_clicked(self.heads)
62     tails_butt = Button(fig.add_axes([0.25,0.02,0.1,0.05]), "tails")
63     tails_butt.label.set_fontsize(self.fontsize)
64     tails_butt.on_clicked(self.tails)
65     save_butt = Button(fig.add_axes ([0.45,0.02,0.1,0.05]), "save")
66     save_butt.label.set_fontsize(self.fontsize)
67     save_butt.on_clicked(self.save)
68     reset_butt = Button(fig.add_axes ([0.85,0.02,0.1,0.05]), "reset")
69     reset_butt.label.set_fontsize(self.fontsize)
70     reset_butt.on_clicked(self.reset)
71     ## draw the distribution
72     self.draw_dist()
73     plt.show()
74
75 def draw_dist(self):
76     sv = self.num/sum(self.dist)
77     self.dist = [v*sv for v in self.dist]
78     #print(self.dist)
79     self.ax.clear()
80     self.ax.set_ylabel("Probability", fontsize=self.fontsize)
81     self.ax.set_xlabel("P(Heads)", fontsize=self.fontsize)
82     self.ax.set_title("Beta Distribution", fontsize=self.fontsize)
83     self.ax.plot(self.vals, self.dist, color='black', label =
84         f"{self.num_heads} heads; {self.num_tails} tails")
85     for (nh,nt,d) in self.saves:
86         self.ax.plot(self.vals, d, label = f"{nh} heads; {nt} tails")
87     self.ax.legend()
88     plt.draw()
89
90 def heads(self,event):
91     self.num_heads += 1
92     self.dist = [self.dist[i]*self.vals[i] for i in range(self.num)]
93     self.draw_dist()
94 def tails(self,event):
95     self.num_tails += 1
96     self.dist = [self.dist[i]*(1-self.vals[i]) for i in range(self.num)]

```

```

96         self.draw_dist()
97     def save(self, event):
98         self.saves.append((self.num_heads, self.num_tails, self.dist))
99         self.draw_dist()
100    def reset(self, event):
101        self.num_tails = 0
102        self.num_heads = 0
103        self.dist = [1/self.num for i in range(self.num)]
104        self.draw_dist()
105
106    # s1 = Show_Beta(100)
107    # s1 = Show_Beta(100, fontsize=15) # for demos - enlarge window
108
109    if __name__ == "__main__":
110        print("Try: Show_Beta(100)")

```

10.2 K-means

The k-means learner takes in a dataset and a number of classes, and learns a mapping from examples to classes (`class_of_eg`) and a function that makes predictions for classes (`class_predictions`).

It maintains two lists that suffice as sufficient statistics to classify examples, and to learn the classification:

- `class_counts` is a list such that `class_counts[c]` is the number of examples in the training set with `class = c`.
- `feature_sum` is a list such that `feature_sum[f][c]` is sum of the values for the feature `f` for members of class `c`. The average value of the *i*th feature in class *i* is

$$\frac{\text{feature_sum}[i][c]}{\text{class_counts}[c]}$$

when `class_counts[c] > 0` and is 0 otherwise.

The class is initialized by randomly assigning examples to classes, and updating the statistics for `class_counts` and `feature_sum`.

```

learnKMeans.py — k-means learning
11 from learnProblem import Data_set, Learner, Data_from_file
12 import random
13 import matplotlib.pyplot as plt
14
15 class K_means_learner(Learner):
16
17     def __init__(self, dataset, num_classes):
18         self.dataset = dataset
19         self.num_classes = num_classes

```

```

20     self.random_initialize()
21     self.max_display_level = 5
22
23     def random_initialize(self):
24         # class_counts[c] is the number of examples with class=c
25         self.class_counts = [0]*self.num_classes
26         # feature_sum[f][c] is the sum of the values of feature f for class
27         # c
28         self.feature_sum = {feat:[0]*self.num_classes
29                             for feat in self.dataset.input_features}
30         for eg in self.dataset.train:
31             cl = random.randrange(self.num_classes) # assign eg to random
32             class
33             self.class_counts[cl] += 1
34             for feat in self.dataset.input_features:
35                 self.feature_sum[feat][cl] += feat(eg)
36         self.num_iterations = 0
37         self.display(1,"Initial class counts: ",self.class_counts)

```

The distance from (the mean of) a class to an example is the sum, over all features, of the sum-of-squares differences of the class mean and the example value.

```

learnKMeans.py — (continued)
37     def distance(self,cl,eg):
38         """distance of the eg from the mean of the class"""
39         return sum( (self.class_prediction(feats,cl)-feats(eg))**2
40                   for feat in self.dataset.input_features)
41
42     def class_prediction(self,feat,cl):
43         """prediction of the class cl on the feature with index feat_ind"""
44         if self.class_counts[cl] == 0:
45             return 0 # arbitrary prediction
46         else:
47             return self.feature_sum[feat][cl]/self.class_counts[cl]
48
49     def class_of_eg(self,eg):
50         """class to which eg is assigned"""
51         return (min((self.distance(cl,eg),cl)
52                   for cl in range(self.num_classes)))[1]
53         # second element of tuple, which is a class with minimum
54         # distance

```

One step of k-means updates the *class_counts* and *feature_sum*. It uses the old values to determine the classes, and so the new values for *class_counts* and *feature_sum*. At the end it determines whether the values of these have changes, and then replaces the old ones with the new ones. It returns an indicator of whether the values are stable (have not changed).

```

learnKMeans.py — (continued)
55     def k_means_step(self):

```

```

56     """Updates the model with one step of k-means.
57     Returns whether the assignment is stable.
58     """
59     new_class_counts = [0]*self.num_classes
60     # feature_sum[f][c] is the sum of the values of feature f for class
        c
61     new_feature_sum = {feat: [0]*self.num_classes
62                       for feat in self.dataset.input_features}
63     for eg in self.dataset.train:
64         cl = self.class_of_eg(eg)
65         new_class_counts[cl] += 1
66         for feat in self.dataset.input_features:
67             new_feature_sum[feat][cl] += feat(eg)
68     stable = (new_class_counts == self.class_counts) and
        (self.feature_sum == new_feature_sum)
69     self.class_counts = new_class_counts
70     self.feature_sum = new_feature_sum
71     self.num_iterations += 1
72     return stable
73
74
75     def learn(self,n=100):
76         """do n steps of k-means, or until convergence"""
77         i=0
78         stable = False
79         while i<n and not stable:
80             stable = self.k_means_step()
81             i += 1
82             self.display(1,"Iteration",self.num_iterations,
83                         "class counts: ",self.class_counts,"
84                         Stable=",stable)
85
86         return stable
87
88     def show_classes(self):
89         """sorts the data by the class and prints in order.
90         For visualizing small data sets
91         """
92         class_examples = [[] for i in range(self.num_classes)]
93         for eg in self.dataset.train:
94             class_examples[self.class_of_eg(eg)].append(eg)
95         print("Class", "Example", sep='\t')
96         for cl in range(self.num_classes):
97             for eg in class_examples[cl]:
98                 print(cl,*eg,sep='\t')

```

Figure 10.3 shows multiple runs for Example 10.5 in Section 10.3.1 of Poole and Mackworth [2023]. Note that the y -axis is sum of squares of the values, which is the square of the Euclidian distance. K-means can stabilize on a different assignment each time it is run. The first run with 2 classes shown in the figure was stable after the first step. The next two runs with 3 classes started

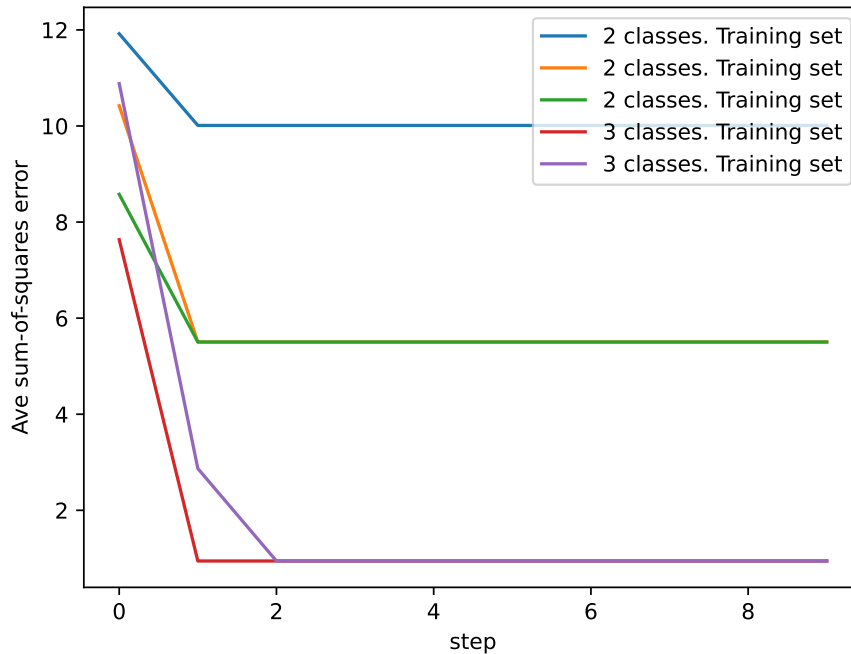

Figure 10.3: k-means plotting error.

with different assignments, but stabilized on the same assignment. (You cannot check if it is the same assignment from the graph, but need to check the assignment of examples to classes.) The second run with 3 classes took two steps to stabilize, but the other only took one. Note that the algorithm only determines that it is stable with one more run.

```

learnKMeans.py — (continued)
97     def plot_error(self, maxstep=20):
98         """Plots the sum-of-squares error as a function of the number of
99             steps"""
100         plt.ion()
101         fig, ax = plt.subplots()
102         ax.set_xlabel("step")
103         ax.set_ylabel("Ave sum-of-squares error")
104         train_errors = []
105         if self.dataset.test:
106             test_errors = []
107         for i in range(maxstep):
108             train_errors.append( sum(self.distance(self.class_of_eg(eg), eg)
109                                   for eg in self.dataset.train)
110                                /len(self.dataset.train))
111             if self.dataset.test:

```

```

111         test_errors.append(
112             sum(self.distance(self.class_of_eg(eg), eg)
113                 for eg in self.dataset.test)
114             /len(self.dataset.test))
115         self.learn(1)
116         ax.plot(range(maxstep), train_errors,
117                 label=str(self.num_classes)+" classes. Training set")
118         if self.dataset.test:
119             ax.plot(range(maxstep), test_errors,
120                     label=str(self.num_classes)+" classes. Test set")
121         ax.legend()
122         plt.draw()
123
124 def testKM():
125     # data = Data_from_file('data/emdata1.csv', num_train=10,
126     #                       target_index=2000) # trivial example
127     data = Data_from_file('data/emdata2.csv', num_train=10,
128     #                       target_index=2000)
129     # data = Data_from_file('data/emdata0.csv', num_train=14,
130     #                       target_index=2000) # example from textbook
131     # data = Data_from_file('data/carbool.csv', target_index=2000,
132     #                       one_hot=True)
133     kml = K_means_learner(data, 2)
134     num_iter=4
135     print("Class assignment after", num_iter, "iterations:")
136     kml.learn(num_iter); kml.show_classes()
137
138 if __name__ == "__main__":
139     testKM()
140
141 # Plot the error
142 # km2=K_means_learner(data,2); km2.plot_error(10) # 2 classes
143 # km3=K_means_learner(data,3); km3.plot_error(10) # 3 classes
144 # km13=K_means_learner(data,10); km13.plot_error(10) # 10 classes

```

Exercise 10.1 If there are many classes, some of the classes can become empty (e.g., try 100 classes with `carbool.csv`). Implement a way to put some examples into a class, if possible. Two ideas are:

- (a) Initialize the classes with actual examples, so that the classes will not start empty. (Do the classes become empty?)
- (b) In *class_prediction*, we test whether the code is empty, and make a prediction of 0 for an empty class. It is possible to make a different prediction to “steal” an example (but you should make sure that a class has a consistent value for each feature in a loop).

Make your own suggestions, and compare it with the original, and whichever of these you think may work better.

10.3 EM

In the following definition, a class, c , is a integer in range $[0, num_classes)$. i is an index of a feature, so $feat[i]$ is the i th feature, and a feature is a function from tuples to values. val is a value of a feature.

A model consists of 2 lists, which form the sufficient statistics:

- *class_counts* is a list such that $class_counts[c]$ is the number of tuples with $class = c$, where each tuple is weighted by its probability, i.e.,

$$class_counts[c] = \sum_{t: class(t)=c} P(t)$$

- *feature_counts* is a list such that $feature_counts[i][val][c]$ is the weighted count of the number of tuples t with $feat[i](t) = val$ and $class(t) = c$, each tuple is weighted by its probability, i.e.,

$$feature_counts[i][val][c] = \sum_{t: feat[i](t)=val \text{ and } class(t)=c} P(t)$$

```

learnEM.py — EM Learning
11 from learnProblem import Data_set, Learner, Data_from_file
12 import random
13 import math
14 import matplotlib.pyplot as plt
15
16 class EM_learner(Learner):
17     def __init__(self, dataset, num_classes):
18         self.dataset = dataset
19         self.num_classes = num_classes
20         self.class_counts = None
21         self.feature_counts = None

```

The function *em_step* goes through the training examples, and updates these counts. The first time it is run, when there is no model, it uses random distributions.

```

learnEM.py — (continued)
23 def em_step(self, orig_class_counts, orig_feature_counts):
24     """updates the model."""
25     class_counts = [0]*self.num_classes
26     feature_counts = [{val:[0]*self.num_classes
27                       for val in feat.frange}
28                      for feat in self.dataset.input_features]
29     for tple in self.dataset.train:
30         if orig_class_counts: # a model exists
31             tpl_class_dist = self.prob(tple, orig_class_counts,
32                                       orig_feature_counts)

```

```

32     else:                # initially, with no model, return a random
                           distribution
33         tpl_class_dist = random_dist(self.num_classes)
34         for cl in range(self.num_classes):
35             class_counts[cl] += tpl_class_dist[cl]
36             for (ind, feat) in enumerate(self.dataset.input_features):
37                 feature_counts[ind][feat(tple)][cl] += tpl_class_dist[cl]
38     return class_counts, feature_counts

```

prob computes the probability of a class c for a tuple $tple$, given the current statistics.

$$\begin{aligned}
 P(c \mid tple) &\propto P(c) * \prod_i P(X_i=tple(i) \mid c) \\
 &= \frac{\text{class_counts}[c]}{\text{len}(\text{self.dataset})} * \prod_i \frac{\text{feature_counts}[i][\text{feat}_i(tple)][c]}{\text{class_counts}[c]} \\
 &\propto \frac{\prod_i \text{feature_counts}[i][\text{feat}_i(tple)][c]}{\text{class_counts}[c]^{|\text{feats}|-1}}
 \end{aligned}$$

The last step is because $\text{len}(\text{self.dataset})$ is a constant (independent of c). $\text{class_counts}[c]$ can be taken out of the product, but needs to be raised to the power of the number of features, and one of them cancels.

```

-----learnEM.py --- (continued) -----
40     def prob(self, tple, class_counts, feature_counts):
41         """returns a distribution over the classes for tuple tple in the
42            model defined by the counts
43            """
44         feats = self.dataset.input_features
45         unnorm = [prod(feature_counts[i][feat(tple)][c]
46                       for (i, feat) in enumerate(feats))
47                  for c in range(self.num_classes)]
48         thesum = sum(unnorm)
49         return [un/thesum for un in unnorm]

```

learn does n steps of EM:

```

-----learnEM.py --- (continued) -----
51     def learn(self, n):
52         """do n steps of em"""
53         for i in range(n):
54             self.class_counts, self.feature_counts =
55                 self.em_step(self.class_counts,
                               self.feature_counts)

```

The following is for visualizing the classes. It prints the dataset ordered by the probability of class c .

```

-----learnEM.py --- (continued) -----
57     def show_class(self, c):

```

```

58     """sorts the data by the class and prints in order.
59     For visualizing small data sets
60     """
61     sorted_data =
62         sorted((self.prob(tpl,self.class_counts,self.feature_counts)[c],
63                ind, # preserve ordering for equal
64                  probabilities
65                tpl)
66               for (ind,tpl) in enumerate(self.dataset.train))
67     for cc,r,tpl in sorted_data:
68         print(cc,*tpl,sep='\t')
```

The following are for evaluating the classes.

The probability of a tuple can be evaluated by marginalizing over the classes:

$$\begin{aligned}
 P(\text{tuple}) &= \sum_c P(c) * \prod_i P(X_i=\text{tuple}(i) | c) \\
 &= \sum_c \frac{cc[c]}{\text{len}(\text{self.dataset})} * \prod_i \frac{fc[i][\text{feat}_i(\text{tuple})][c]}{cc[c]}
 \end{aligned}$$

where cc is the class count and fc is feature count. $\text{len}(\text{self.dataset})$ can be distributed out of the sum, and $cc[c]$ can be taken out of the product:

$$= \frac{1}{\text{len}(\text{self.dataset})} \sum_c \frac{1}{cc[c]^{\#\text{feats}-1}} * \prod_i fc[i][\text{feat}_i(\text{tuple})][c]$$

Given the probability of each tuple, we can evaluate the logloss, as the negative of the log probability:

```

learnEM.py — (continued)
68     def logloss(self,tuple):
69         """returns the logloss of the prediction on tuple, which is
70         -log(P(tuple))
71         based on the current class counts and feature counts
72         """
73         feats = self.dataset.input_features
74         res = 0
75         cc = self.class_counts
76         fc = self.feature_counts
77         for c in range(self.num_classes):
78             res += prod(fc[i][feat(tuple)][c]
79                       for (i,feat) in
80                         enumerate(feats))/(cc[c]**(len(feats)-1))
81         if res>0:
82             return -math.log2(res/len(self.dataset.train))
83         else:
84             return float("inf") #infinity
```

Figure 10.4 shows the training and test error for various numbers of classes for the carbool dataset (calls commented out at the end of the code).

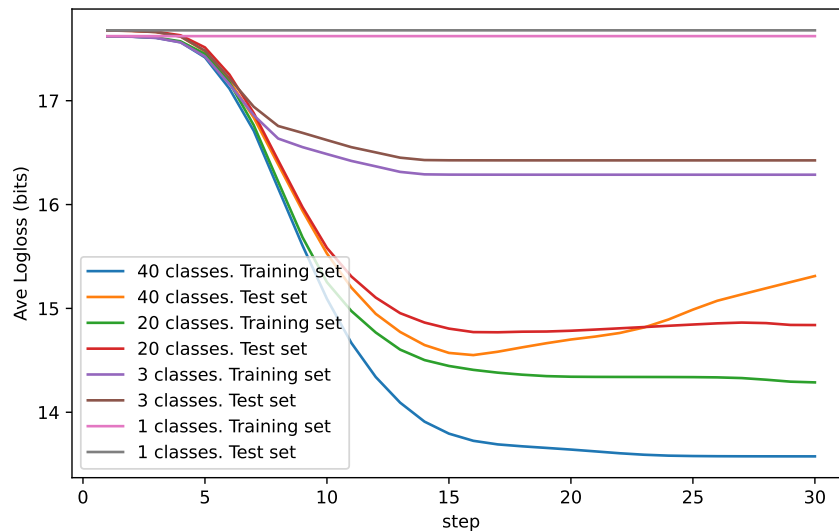

Figure 10.4: EM plotting error.

learnEM.py — (continued)

```

84 def plot_error(self, maxstep=20):
85     """Plots the logloss error as a function of the number of steps"""
86     plt.ion()
87     ax.set_xlabel("step")
88     ax.set_ylabel("Ave Logloss (bits)")
89     train_errors = []
90     if self.dataset.test:
91         test_errors = []
92     for i in range(maxstep):
93         self.learn(1)
94         train_errors.append( sum(self.logloss(tple) for tple in
95                               self.dataset.train)
96                               /len(self.dataset.train))
97         if self.dataset.test:
98             test_errors.append( sum(self.logloss(tple) for tple in
99                                   self.dataset.test)
100                                /len(self.dataset.test))
101     ax.plot(range(1,maxstep+1),train_errors,
102            label=str(self.num_classes)+" classes. Training set")
103     if self.dataset.test:
104         ax.plot(range(1,maxstep+1),test_errors,
105                label=str(self.num_classes)+" classes. Test set")
106     ax.legend()
107     plt.show()
# global variables so the plots can share axes.

```

```

108 fig, ax = plt.subplots()
109
110 def prod(L):
111     """returns the product of the elements of L"""
112     res = 1
113     for e in L:
114         res *= e
115     return res
116
117 def random_dist(k):
118     """generate k random numbers that sum to 1"""
119     res = [random.random() for i in range(k)]
120     s = sum(res)
121     return [v/s for v in res]
122
123 def testEM():
124     print("testing EM")
125     global data, eml
126     data = Data_from_file('data/emdata2.csv', num_train=10,
127                          target_index=2000)
127     # data = Data_from_file('data/carbool.csv', target_index=2000,
128                          one_hot=True)
128     eml = EM_learner(data,2)
129     num_iter=2
130     print("Class assignment after",num_iter,"iterations:")
131     eml.learn(num_iter); eml.show_class(0)
132
133 if __name__ == "__main__":
134     testEM()
135
136 # Plot the error
137 # em1=EM_learner(data,1); em1.plot_error(30) # 1 class (predict mean)
138 # em2=EM_learner(data,2); em2.plot_error(40) # 2 classes
139 # em3=EM_learner(data,3); em3.plot_error(40) # 3 classes
140 # em10=EM_learner(data,10); em10.plot_error(40) # 10 classes
141 # em13=EM_learner(data,13); em13.plot_error(40) # 13 classes
142
143 # show the values for the variables
144 # [f.frange for f in data.input_features]

```

Exercise 10.2 For data where there are naturally 2 classes, does EM with 3 classes do better on the training set after a while than 2 classes? Is it better on a test set. Explain why. Hint: look what the 3 classes are. Use "eml.show_class(i)" for each of the classes $i \in [0,3)$.

Exercise 10.3 Write code to plot the logloss as a function of the number of classes (from 1 to, say, 30) for a fixed number of iterations. (From the experience with the existing code, think about how many iterations are appropriate.

Exercise 10.4 Repeat the previous exercise, but use cross validation to select the number of iterations as a function of the number of classes and other features of

the dataset.

Causality

11.1 Do Questions

A causal model can answer “do” questions.

The `intervene` function takes a belief network and a *variable : value* dictionary specifying what to “do”, and returns a belief network resulting from intervening to set each variable in the dictionary to its value specified. It replaces the conditional probability distribution, CPD, (Section 9.3) of each intervened variable with an constant CPD.

```
probDo.py — Probabilistic inference with the do operator
11 from probGraphicalModels import InferenceMethod, BeliefNetwork
12 from probFactors import CPD, ConstantCPD
13
14 def intervene(bn, do={}):
15     assert isinstance(bn, BeliefNetwork), f"Do only applies to belief
16         networks ({bn.title})"
17     if do=={}:
18         return bn
19     else:
20         newfacs = ({f for (ch,f) in bn.var2cpt.items() if ch not in do} |
21             {ConstantCPD(v,c) for (v,c) in do.items()})
22         return BeliefNetwork(f"{bn.title}(do={do})", bn.variables, newfacs)
```

The following adds the `queryDo` method to the `InferenceMethod` class, so it can be used with any inference method. It replaces the graphical model with the modified one, runs the inference algorithm, and restores the initial belief network.

```
probDo.py — (continued)
23 def queryDo(self, qvar, obs={}, do={}):
```

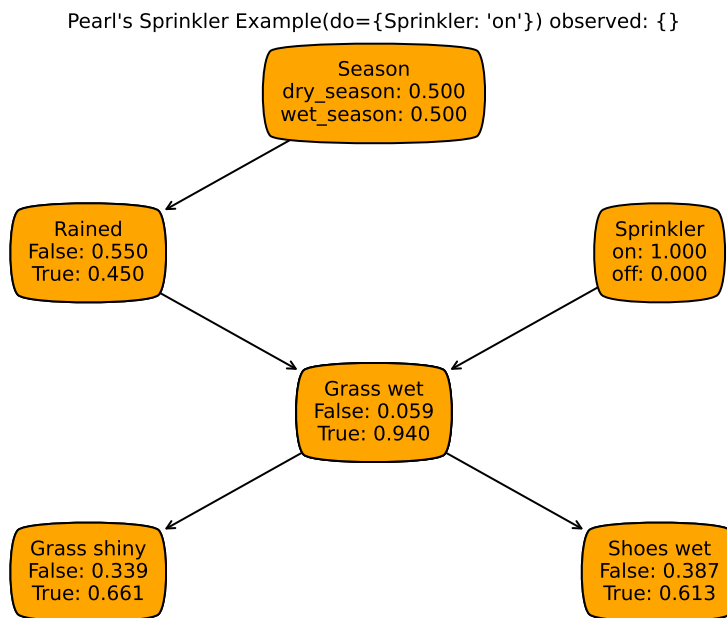

Figure 11.1: The sprinkler belief network with $do=\{\text{Sprinkler: "on"}\}$.

```

24     """Extends query method to also allow for interventions.
25     """
26     oldBN, self.gm = self.gm, intervene(self.gm, do)
27     result = self.query(qvar, obs)
28     self.gm = oldBN # restore original
29     return result
30
31 # make queryDo available for all inference methods
32 InferenceMethod.queryDo = queryDo

```

The following example is based on the sprinkler belief network of Section 9.4.2 shown in Figure 9.4. The network with the intervention of putting the sprinkler on is shown in Figure 11.1.

```

_____probDo.py — (continued)_____
34 from probRC import ProbRC
35
36 from probExamples import bn_sprinkler, Season, Sprinkler, Rained,
    Grass_wet, Grass_shiny, Shoes_wet
37 bn_sprinklerv = ProbRC(bn_sprinkler)
38 ## bn_sprinklerv.queryDo(Shoes_wet)
39 ## bn_sprinklerv.queryDo(Shoes_wet,obs={Sprinkler:"on"})
40 ## bn_sprinklerv.queryDo(Shoes_wet,do={Sprinkler:"on"})
41 ## bn_sprinklerv.queryDo(Season, obs={Sprinkler:"on"})
42 ## bn_sprinklerv.queryDo(Season, do={Sprinkler:"on"})

```

Gateway Drug? observed: {}

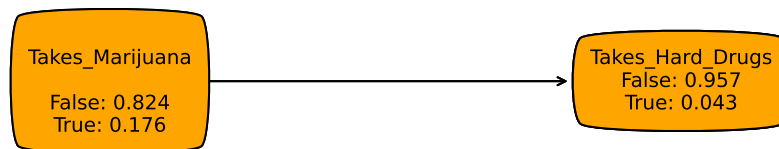

Figure 11.2: Does taking marijuana lead to hard drugs: observable variables

```

43
44 ### Showing posterior distributions:
45 # bn_sprinklerv.show_post({})
46 # bn_sprinklerv.show_post({Sprinkler:"on"})
47 # spon = intervene(bn_sprinkler, do={Sprinkler:"on"})
48 # ProbRC(spon).show_post({})
  
```

The following is a representation of a possible model where marijuana is a gateway drug to harder drugs (or not). Before reading the code, try the commented-out queries at the end. Figure 11.2 shows the network with the observable variables, `Takes_Marijuana` and `Takes_Hard_Drugs`.

```

_____probDo.py — (continued)_____
50 from variable import Variable
51 from probFactors import Prob
52 from probGraphicalModels import BeliefNetwork
53 boolean = [False, True]
54
55 Drug_Prone = Variable("Drug_Prone", boolean, position=(0.1,0.5)) #
    (0.5,0.9)
56 Side_Effects = Variable("Side_Effects", boolean, position=(0.1,0.5)) #
    (0.5,0.1)
57 Takes_Marijuana = Variable("\nTakes_Marijuana\n", boolean,
    position=(0.1,0.5))
58 Takes_Hard_Drugs = Variable("Takes_Hard_Drugs", boolean,
    position=(0.9,0.5))
59
60 p_dp = Prob(Drug_Prone, [], [0.8, 0.2])
61 p_be = Prob(Side_Effects, [Takes_Marijuana], [[1, 0], [0.4, 0.6]])
62 p_tm = Prob(Takes_Marijuana, [Drug_Prone], [[0.98, 0.02], [0.2, 0.8]])
63 p_thd = Prob(Takes_Hard_Drugs, [Side_Effects, Drug_Prone],
64             # Drug_Prone=False Drug_Prone=True
65             [[0.999, 0.001], [0.6, 0.4]], # Side_Effects=False
66             [[0.99999, 0.00001], [0.995, 0.005]]) # Side_Effects=True
67
  
```

```

68 | drugs = BeliefNetwork("Gateway Drug?",
69 |                       [Drug_Prone, Side_Effects, Takes_Marijuana,
70 |                       Takes_Hard_Drugs],
71 |                       [p_tm, p_dp, p_be, p_thd])
72 |
73 | drugsq = ProbRC(drugs)
74 | # drugsq.queryDo(Takes_Hard_Drugs)
75 | # drugsq.queryDo(Takes_Hard_Drugs, obs = {Takes_Marijuana: True})
76 | # drugsq.queryDo(Takes_Hard_Drugs, obs = {Takes_Marijuana: False})
77 | # drugsq.queryDo(Takes_Hard_Drugs, do = {Takes_Marijuana: True})
78 | # drugsq.queryDo(Takes_Hard_Drugs, do = {Takes_Marijuana: False})
79 |
80 | # ProbRC(drugs).show_post({})
81 | # ProbRC(drugs).show_post({Takes_Marijuana: True})
82 | # ProbRC(drugs).show_post({Takes_Marijuana: False})
83 | # ProbRC(intervene(drugs, do={Takes_Marijuana: True})).show_post({})
84 | # ProbRC(intervene(drugs, do={Takes_Marijuana: False})).show_post({})
85 | # Why was that? Try the following then repeat:
86 | # Drug_Prone.position=(0.5,0.7); Side_Effects.position=(0.5,0.3)

```

11.2 Counterfactual Reasoning

The following provides two examples of counterfactual reasoning. In the following code, the user has to provide the deterministic system with noise. As we will see, there are multiple deterministic systems with noise that can produce the same causal probabilities.

```

_____probCounterfactual.py — Counterfactual Query Example_____
11 | from variable import Variable
12 | from probFactors import Prob, ProbDT, IFeq, SameAs, Dist
13 | from probGraphicalModels import BeliefNetwork
14 | from probRC import ProbRC
15 | from probDo import queryDo
16 |
17 | boolean = [False, True]

```

11.2.1 Choosing Deterministic System

This section presents an example to encourage you to think about what deterministic system to use.

Consider the following example (thanks to Sophie Song). Suppose Bob went on a date with Alice. Bob was either on time or not (variable B is true when Bob is on time). Alice, who is fastidious about punctuality chooses whether to go on a second date (variable A is true when Alice agrees to a second date). Whether Bob is late depends on which cab company he called (variable C). Suppose Bob calls one of the cab companies, he was late, and Alice doesn't ask for a second date. Bob wonders "what if I had called the other

CBA Counterfactual Example

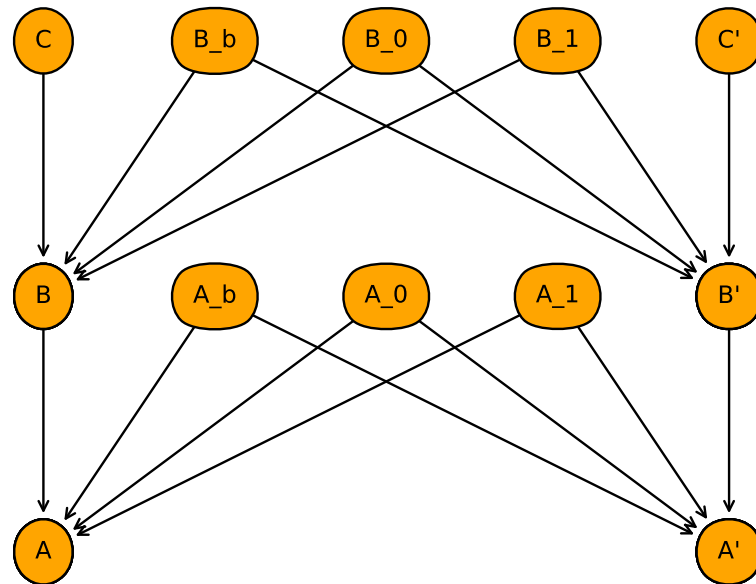

Figure 11.3: $C \rightarrow B \rightarrow A$ belief network for “what if C ”. Figure generated by `cbaCounter.show()`

cab company”. Suppose all variables are Boolean. C causally depends on B , and not directly on C , and B depends on C , so the appropriate causal model is $C \rightarrow B \rightarrow A$.

Assume the following probabilities obtained from observations (where the lower case c represents $C = \text{true}$, and similarly for other variables):

$$P(c) = 0.5$$

$$P(b | c) = P(b | \neg c) = 0.7 \quad (\text{the cab companies are equally reliable})$$

$$(a | b) = 0.4, (a | \neg b) = 0.2.$$

Consider “what if C was True” or “what if C was False”. For example, suppose $A = \text{false}$ and $C = \text{false}$ is observed and you want the probability of A if C were false.

Figure 11.3 shows the paired network for “what if C ”. The primed variables represent the situation where C is counterfactually True or False. In this network, C_{prime} should be conditioned on. Conditioning on C_{prime} should not affect the non-primed variables. (You should check this).

```

probCounterfactual.py — (continued)
19 # as a deterministic system with independent noise
20 C = Variable("C", boolean, position=(0.1,0.8))
21 B = Variable("B", boolean, position=(0.1,0.4))
22 A = Variable("A", boolean, position=(0.1,0.0))
23 Cprime = Variable("C'", boolean, position=(0.9,0.8))
24 Bprime = Variable("B'", boolean, position=(0.9,0.4))
25 Aprime = Variable("A'", boolean, position=(0.9,0.0))
26 B_b = Variable("B_b", boolean, position=(0.3,0.8))
27 B_0 = Variable("B_0", boolean, position=(0.5,0.8))
28 B_1 = Variable("B_1", boolean, position=(0.7,0.8))
29 A_b = Variable("A_b", boolean, position=(0.3,0.4))
30 A_0 = Variable("A_0", boolean, position=(0.5,0.4))
31 A_1 = Variable("A_1", boolean, position=(0.7,0.4))

```

The conditional probability $P(A | B)$ is represented using three noise parameters, A_b , A_0 and A_1 , with the equivalence:

$$a \equiv a_b \vee (\neg b \wedge a_0) \vee (b \wedge a_1)$$

Thus a_b is the background cause of a , a_0 is the cause used when $B=false$ and a_1 is the cause used when $B=true$. Note that this is over parametrized with respect the belief network, using three parameters whereas arbitrary conditional probability can be represented using two parameters.

The running example where $(a | b) = 0.4$ and $(a | \neg b) = 0.2$ can be represented using

$$P(a_b) = 0, P(a_0) = 0.2, P(a_1) = 0.4$$

or

$$P(a_b) = 0.2, P(a_0) = 0, P(a_1) = 0.25$$

(and infinitely many others between these). These cannot be distinguished by observations or by interventions. As you can see if you play with the code, these have different counterfactual conclusions.

$P(B | C)$ is represented similarly, using variables B_b , B_0 , and B_1 .

The following code uses the decision tree representation of conditional probabilities of Section 9.3.4.

```

probCounterfactual.py — (continued)
33 p_C = Prob(C, [], [0.5,0.5])
34 p_B = ProbDT(B, [C, B_b, B_0, B_1], IFeq(B_b,True,Dist([0,1]),
35                                     IFeq(C,True,SameAs(B_1),SameAs(B_0))))
36 p_A = ProbDT(A, [B, A_b, A_0, A_1], IFeq(A_b,True,Dist([0,1]),
37                                     IFeq(B,True,SameAs(A_1),SameAs(A_0))))
38 p_Cprime = Prob(Cprime,[], [0.5,0.5])
39 p_Bprime = ProbDT(Bprime, [Cprime, B_b, B_0, B_1],
40                       IFeq(B_b,True,Dist([0,1]),

```

```

41         IFeq(Cprime, True, SameAs(B_1), SameAs(B_0))))
42 p_Aprime = ProbDT(Aprime, [Bprime, A_b, A_0, A_1],
43         IFeq(A_b, True, Dist([0, 1]),
44         IFeq(Bprime, True, SameAs(A_1), SameAs(A_0))))
45 p_b_b = Prob(B_b, [], [1, 0])
46 p_b_0 = Prob(B_0, [], [0.3, 0.7])
47 p_b_1 = Prob(B_1, [], [0.3, 0.7])
48
49 p_a_b = Prob(A_b, [], [1, 0])
50 p_a_0 = Prob(A_0, [], [0.8, 0.2])
51 p_a_1 = Prob(A_1, [], [0.6, 0.4])
52
53 p_b_np = Prob(B, [], [0.3, 0.7]) # for AB network
54 p_Bprime_np = Prob(Bprime, [], [0.3, 0.7]) # for AB network
55 ab_Counter = BeliefNetwork("AB Counterfactual Example",
56         [A, B, Aprime, Bprime, A_b, A_0, A_1],
57         [p_A, p_b_np, p_Aprime, p_Bprime_np, p_a_b, p_a_0,
58         p_a_1])
59 cbaCounter = BeliefNetwork("CBA Counterfactual Example",
60         [A, B, C, Aprime, Bprime, Cprime, B_b, B_0, B_1, A_b, A_0, A_1],
61         [p_A, p_B, p_C, p_Aprime, p_Bprime, p_Cprime,
62         p_b_b, p_b_0, p_b_1, p_a_b, p_a_0, p_a_1])

```

Here are some queries you might like to try. The `show_post` queries might be most useful if you have the space to show multiple queries.

probCounterfactual.py — (continued)

```

64 cbaq = ProbRC(cbaCounter)
65 # cbaq.queryDo(Aprime, obs = {C:True, Cprime:False})
66 # cbaq.queryDo(Aprime, obs = {C:False, Cprime:True})
67 # cbaq.queryDo(Aprime, obs = {A:True, C:True, Cprime:False})
68 # cbaq.queryDo(Aprime, obs = {A:False, C:True, Cprime:False})
69 # cbaq.queryDo(Aprime, obs = {A:False, C:True, Cprime:False})
70 # cbaq.queryDo(A_1, obs = {C:True, Aprime:False})
71 # cbaq.queryDo(A_0, obs = {C:True, Aprime:False})
72
73 # cbaq.show_post(obs = {})
74 # cbaq.show_post(obs = {C:True, Cprime:False})
75 # cbaq.show_post(obs = {A:False, C:True, Cprime:False})
76 # cbaq.show_post(obs = {A:True, C:True, Cprime:False})

```

Exercise 11.1 Consider the scenario “Bob called the first cab ($C = \text{true}$), was late and Alice agrees to a second date”. What would you expect from the scenario “what if Bob called the other cab?”. What does the network predict? Design probabilities for the noise variables that fits the conditional probability and also fits your expectation.

Exercise 11.2 How would you expect the counterfactual conclusion to change given the following two scenarios that fit the story:

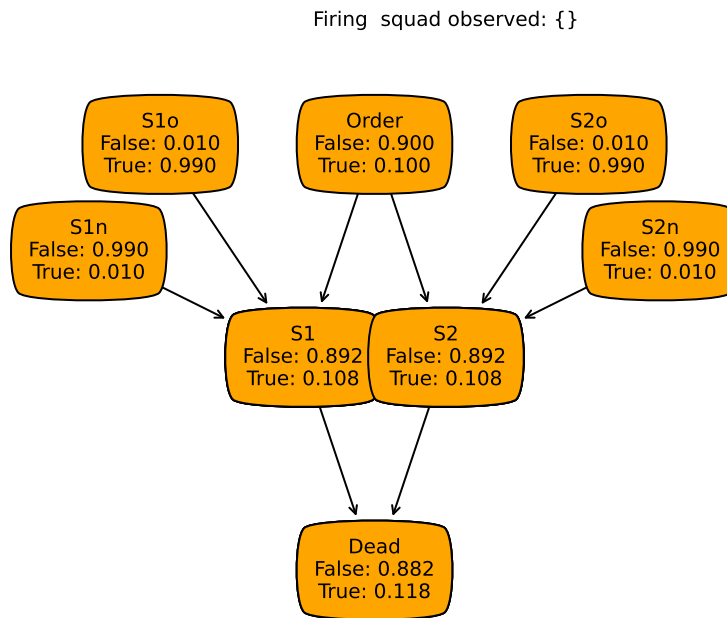

Figure 11.4: Firing squad belief network (figure obtained from `fsq.show_post({})`)

- The cabs are both very reliable and start at the same location (and so face the same traffic).
 - The cabs are each 90% reliable and start from opposite directions.
- (a) How would you expect the predictions to differ in these two cases?
 - (b) How can you fit the conditional probabilities above and represent each of these by changing the probabilities of the noise variables?
 - (c) How can these be learned from data? (Hint: consider learning a correlation between the taxi arrivals). Is your approach always applicable? If not, for which cases is it applicable or not.

Exercise 11.3 Choose two assignments to values to each of a_b , a_0 and a_1 using $a \equiv a_b \vee (\neg b \wedge a_0) \vee (b \wedge a_1)$, and a counterfactual query such that (a) the two assignments cannot be distinguished by observations or by interventions, and (b) the predictions for the query differ by an arbitrarily large amount (differ by $1 - \epsilon$ for a small value of ϵ , such as $\epsilon = 0.1$).

11.2.2 Firing Squad Example

The following is the firing squad example of Pearl [2009] as a deterministic system. See Figure 11.4.

_probCounterfactual.py — (continued) _

```

78 Order = Variable("Order", boolean, position=(0.4,0.8))
79 S1 = Variable("S1", boolean, position=(0.3,0.4))
80 S1o = Variable("S1o", boolean, position=(0.1,0.8))
81 S1n = Variable("S1n", boolean, position=(0.0,0.6))
82 S2 = Variable("S2", boolean, position=(0.5,0.4))
83 S2o = Variable("S2o", boolean, position=(0.7,0.8))
84 S2n = Variable("S2n", boolean, position=(0.8,0.6))
85 Dead = Variable("Dead", boolean, position=(0.4,0.0))

```

Instead of the tabular representation of the if-then-else structure used for the $A \rightarrow B \rightarrow C$ network above, the following uses the decision tree representation of conditional probabilities of Section 9.3.4.

```

-----probCounterfactual.py ----- (continued) -----
87 p_S1 = ProbDT(S1, [Order, S1o, S1n],
88             IFeq(Order, True, SameAs(S1o), SameAs(S1n)))
89 p_S2 = ProbDT(S2, [Order, S2o, S2n],
90             IFeq(Order, True, SameAs(S2o), SameAs(S2n)))
91 p_dead = Prob(Dead, [S1, S2], [[[1,0],[0,1]],[[0,1],[0,1]]])
92         #IFeq(S1, True, True, SameAs(S2))
93 p_order = Prob(Order, [], [0.9, 0.1])
94 p_s1o = Prob(S1o, [], [0.01, 0.99])
95 p_s1n = Prob(S1n, [], [0.99, 0.01])
96 p_s2o = Prob(S2o, [], [0.01, 0.99])
97 p_s2n = Prob(S2n, [], [0.99, 0.01])
98
99 firing_squad = BeliefNetwork("Firing squad",
100                             [Order, S1, S1o, S1n, S2, S2o, S2n, Dead],
101                             [p_order, p_dead, p_S1, p_s1o, p_s1n, p_S2, p_s2o,
102                             p_s2n])
102 fsq = ProbRC(firing_squad)
103 # fsq.queryDo(Dead)
104 # fsq.queryDo(Order, obs={Dead:True})
105 # fsq.queryDo(Dead, obs={Order:True})
106 # fsq.show_post({})
107 # fsq.show_post({Dead:True})
108 # fsq.show_post({S2:True})

```

Exercise 11.4 Create the network for “what if shooter 2 did or did not shoot”. Give the probabilities of the following counterfactuals:

- The prisoner is dead; what is the probability that the prisoner would be dead if shooter 2 did not shoot?
- Shooter 2 shot; what is the probability that the prisoner would be dead if shooter 2 did not shoot?
- No order was given, but the prisoner is dead; what is the probability that the prisoner would be dead if shooter 2 did not shoot?

Exercise 11.5 Create the network for “what if the order was or was not given”. Give the probabilities of the following counterfactuals:

- (a) The prisoner is dead; what is the probability that the prisoner would be dead if the order was not given?
- (b) The prisoner is not dead; what is the probability that the prisoner would be dead if the order was not given? (Is this different from the prior that the prisoner is dead, or the posterior that the prisoner was dead given the order was not given).
- (c) Shooter 2 shot; what is the probability that the prisoner would be dead if the order was not given?
- (d) Shooter 2 did not shoot; what is the probability that the prisoner would be dead if the order was given? (Is this different from the probability that the prisoner would be dead if the order was given without the counterfactual observation)?

Planning with Uncertainty

12.1 Decision Networks

The decision network code builds on the representation for belief networks of Chapter 9.

First, define factors that define the utility. Here the **utility** is a function of the variables in *vars*. In a **utility table** the utility is defined in terms of a tabular factor – a list that enumerates the values – as in Section 9.3.3. Another representations for factors (Section 9.2) could able be used.

```
_____decnNetworks.py — Representations for Decision Networks _____
11 from probGraphicalModels import GraphicalModel, BeliefNetwork
12 from probFactors import Factor, CPD, TabFactor, factor_times, Prob
13 from variable import Variable
14 import matplotlib.pyplot as plt
15
16 class Utility(Factor):
17     """A factor defining a utility"""
18     pass
19
20 class UtilityTable(TabFactor, Utility):
21     """A factor defining a utility using a table"""
22     def __init__(self, vars, table, position=None):
23         """Creates a factor on vars from the table.
24         The table is ordered according to vars.
25         """
26         TabFactor.__init__(self, vars, table, name="Utility")
27         self.position = position
```

A **decision variable** is like a random variable with a string name, and a domain, which is a list of possible values. The decision variable also includes the

parents, a list of the variables whose value will be known when the decision is made. It also includes a position, which is used for plotting.

```

----- decnNetworks.py --- (continued) -----
29 class DecisionVariable(Variable):
30     def __init__(self, name, domain, parents, position=None):
31         Variable.__init__(self, name, domain, position)
32         self.parents = parents
33         self.all_vars = set(parents) | {self}

```

A decision network is a graphical model where the variables can be random variables or decision variables. Among the factors we assume there is one utility factor. Note that this is an instance of BeliefNetwork but overrides `__init__`.

```

----- decnNetworks.py --- (continued) -----
35 class DecisionNetwork(BeliefNetwork):
36     def __init__(self, title, vars, factors):
37         """title is a string
38         vars is a list of variables (random and decision)
39         factors is a list of factors (instances of CPD and Utility)
40         """
41         GraphicalModel.__init__(self, title, vars, factors)
42         # not BeliefNetwork.__init__
43         self.var2parents = ({v : v.parents for v in vars
44                             if isinstance(v,DecisionVariable)}
45                             | {f.child:f.parents for f in factors
46                             if isinstance(f,CPD)})
47         self.children = {n:[] for n in self.variables}
48         for v in self.var2parents:
49             for par in self.var2parents[v]:
50                 self.children[par].append(v)
51         self.utility_factor = [f for f in factors
52                               if isinstance(f,Utility)][0]
53         self.topological_sort_saved = None
54
55     def __str__(self):
56         return self.title

```

The split order ensures that the parents of a decision node are split before the decision node, and no other variables (if that is possible).

```

----- decnNetworks.py --- (continued) -----
58     def split_order(self):
59         so = []
60         tops = self.topological_sort()
61         for v in tops:
62             if isinstance(v,DecisionVariable):
63                 so += [p for p in v.parents if p not in so]
64                 so.append(v)
65         so += [v for v in tops if v not in so]
66         return so

```

```

decnNetworks.py — (continued)
68     def show(self, fontsize=10,
69             colors={'utility':'red', 'decision':'lime', 'random':'orange'}):
70         plt.ion() # interactive
71         fig, ax = plt.subplots()
72         ax.set_axis_off()
73         ax.set_title(self.title, fontsize=fontsize)
74         for par in self.utility_factor.variables:
75             ax.annotate("Utility", par.position,
76                       xytext=self.utility_factor.position,
77                       arrowprops={'arrowstyle':'<-'},
78                       bbox=dict(boxstyle="sawtooth,pad=1.0",
79                               facecolor=colors['utility']),
80                       ha='center', va='center', fontsize=fontsize)
81         for var in reversed(self.topological_sort()):
82             if isinstance(var, DecisionVariable):
83                 bbox = dict(boxstyle="square,pad=1.0",
84                             facecolor=colors['decision'])
85             else:
86                 bbox = dict(boxstyle="round4,pad=1.0,rounding_size=0.5",
87                             facecolor=colors['random'])
88             if self.var2parents[var]:
89                 for par in self.var2parents[var]:
90                     ax.annotate(var.name, par.position, xytext=var.position,
91                               arrowprops={'arrowstyle':'<-'},bbox=bbox,
92                               ha='center', va='center',
93                               fontsize=fontsize)
94             else:
95                 x,y = var.position
96                 ax.text(x,y,var.name,bbox=bbox,ha='center', va='center',
97                        fontsize=fontsize)

```

12.1.1 Example Decision Networks

Umbrella Decision Network

Here is a simple "umbrella" decision network. The output of `umbrella_dn.show()` is shown in Figure 12.1.

```

decnNetworks.py — (continued)
98 Weather = Variable("Weather", ["NoRain", "Rain"],
99                    position=(0.5,0.8))
100 Forecast = Variable("Forecast", ["Sunny", "Cloudy", "Rainy"],
101                    position=(0,0.4))
102 # Each variant uses one of the following:
103 Umbrella = DecisionVariable("Umbrella", ["Take", "Leave"], {Forecast},
104                             position=(0.5,0))
105
106 p_weather = Prob(Weather, [], {"NoRain":0.7, "Rain":0.3})
107 p_forecast = Prob(Forecast, [Weather],

```

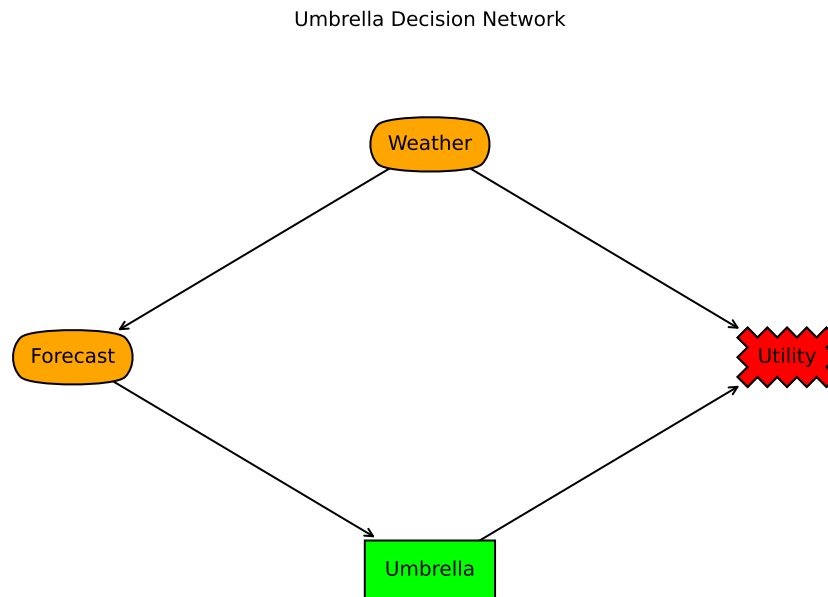

Figure 12.1: The umbrella decision network. Figure generated by `umbrella_dn.show()`

```

108         {"NoRain":{"Sunny":0.7, "Cloudy":0.2, "Rainy":0.1},
109          "Rain":{"Sunny":0.15, "Cloudy":0.25, "Rainy":0.6}})
110 umb_utility = UtilityTable([Weather, Umbrella],
111                             {"NoRain":{"Take":20, "Leave":100},
112                              "Rain":{"Take":70, "Leave":0}}, position=(1,0.4))
113
114 umbrella_dn = DecisionNetwork("Umbrella Decision Network",
115                               {Weather, Forecast, Umbrella},
116                               {p_weather, p_forecast, umb_utility})
117
118 # umbrella_dn.show()
119 # umbrella_dn.show(fontsize=15)

```

The following is a variant with the umbrella decision having 2 parents; nothing else has changed. This is interesting because one of the parents is not needed; if the agent knows the weather, it can ignore the forecast.

```

decnNetworks.py — (continued)
121 Umbrella2p = DecisionVariable("Umbrella", ["Take", "Leave"],
122                               {Forecast, Weather}, position=(0.5,0))
123 umb_utility2p = UtilityTable([Weather, Umbrella2p],
124                              {"NoRain":{"Take":20, "Leave":100},
125                               "Rain":{"Take":70, "Leave":0}},
126                              position=(1,0.4))

```

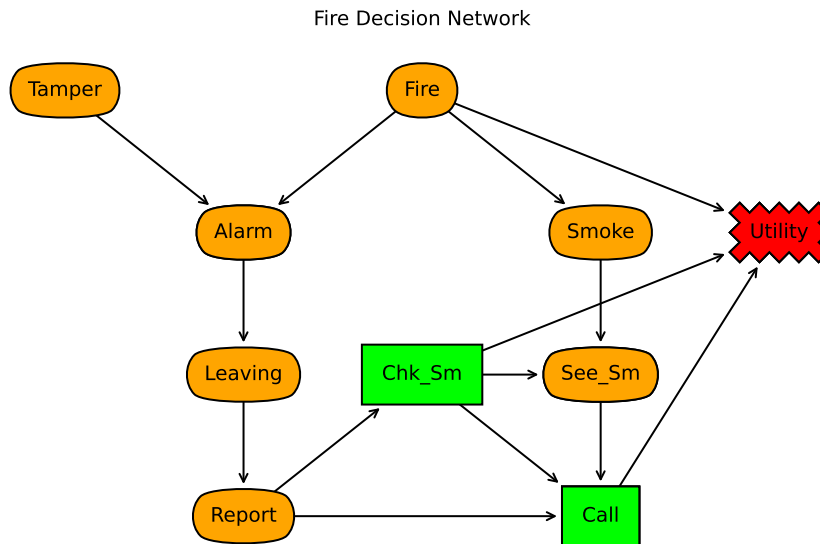

Figure 12.2: Fire Decision Network. Figure generated by `fire_dn.show()`

```

127 | umbrella_dn2p = DecisionNetwork("Umbrella Decision Network (extra arc)",
128 |                               {Weather, Forecast, Umbrella2p},
129 |                               {p_weather, p_forecast, umb_utility2p})
130 |
131 | # umbrella_dn2p.show()
132 | # umbrella_dn2p.show(fontsize=15)

```

Fire Decision Network

The fire decision network of Figure 12.2 (showing the result of `fire_dn.show()`) is represented as:

```

----- decnNetworks.py --- (continued) -----
134 | boolean = [False, True]
135 | Alarm = Variable("Alarm", boolean, position=(0.25,0.633))
136 | Fire = Variable("Fire", boolean, position=(0.5,0.9))
137 | Leaving = Variable("Leaving", boolean, position=(0.25,0.366))
138 | Report = Variable("Report", boolean, position=(0.25,0.1))
139 | Smoke = Variable("Smoke", boolean, position=(0.75,0.633))
140 | Tamper = Variable("Tamper", boolean, position=(0,0.9))
141 |
142 | See_Sm = Variable("See_Sm", boolean, position=(0.75,0.366) )
143 | Chk_Sm = DecisionVariable("Chk_Sm", boolean, {Report},

```

```

144         position=(0.5, 0.366))
145 Call = DecisionVariable("Call", boolean, {See_Sm, Chk_Sm, Report},
146         position=(0.75, 0.1))
147
148 f_ta = Prob(Tamper, [], [0.98, 0.02])
149 f_fi = Prob(Fire, [], [0.99, 0.01])
150 f_sm = Prob(Smoke, [Fire], [[0.99, 0.01], [0.1, 0.9]])
151 f_al = Prob(Alarm, [Fire, Tamper], [[[0.9999, 0.0001], [0.15, 0.85]],
152         [[0.01, 0.99], [0.5, 0.5]]])
153 f_lv = Prob(Leaving, [Alarm], [[0.999, 0.001], [0.12, 0.88]])
154 f_re = Prob(Report, [Leaving], [[0.99, 0.01], [0.25, 0.75]])
155 f_ss = Prob(See_Sm, [Chk_Sm, Smoke], [[[1, 0], [1, 0]], [[1, 0], [0, 1]]])
156
157 ut = UtilityTable([Chk_Sm, Fire, Call],
158         [[[-200], [-5000, -200]], [[-20, -220], [-5020, -220]]],
159         position=(1, 0.633))
160
161 fire_dn = DecisionNetwork("Fire Decision Network",
162         {Tamper, Fire, Alarm, Leaving, Smoke, Call, See_Sm, Chk_Sm, Report},
163         {f_ta, f_fi, f_sm, f_al, f_lv, f_re, f_ss, ut})
164
165 # print(ut.to_table())
166 # fire_dn.show()
167 # fire_dn.show(fontsize=15)

```

Cheating Decision Network

The following is the representation of the cheating decision shown in Figure 12.3. Someone has to decide whether to cheat at two different times. Cheating can improve grades. However, someone is watching for cheating, and if caught, results in punishment. The utility is a combination of final grade and the punishment. The decision maker finds out whether they were caught the first time when they have to decide whether to cheat the second time.

```

----- decnNetworks.py — (continued) -----
169 grades = ['A', 'B', 'C', 'F']
170 Watched = Variable("Watched", boolean, position=(0, 0.9))
171 Caught1 = Variable("Caught1", boolean, position=(0.2, 0.7))
172 Caught2 = Variable("Caught2", boolean, position=(0.6, 0.7))
173 Punish = Variable("Punish", ["None", "Suspension", "Recorded"],
174         position=(0.8, 0.9))
175 Grade_1 = Variable("Grade_1", grades, position=(0.2, 0.3))
176 Grade_2 = Variable("Grade_2", grades, position=(0.6, 0.3))
177 Fin_Grd = Variable("Fin_Grd", grades, position=(0.8, 0.1))
178 Cheat_1 = DecisionVariable("Cheat_1", boolean, set(), position=(0, 0.5))
179 Cheat_2 = DecisionVariable("Cheat_2", boolean, {Cheat_1, Caught1},
180         position=(0.4, 0.5))
181
182 p_wa = Prob(Watched, [], [0.7, 0.3])

```

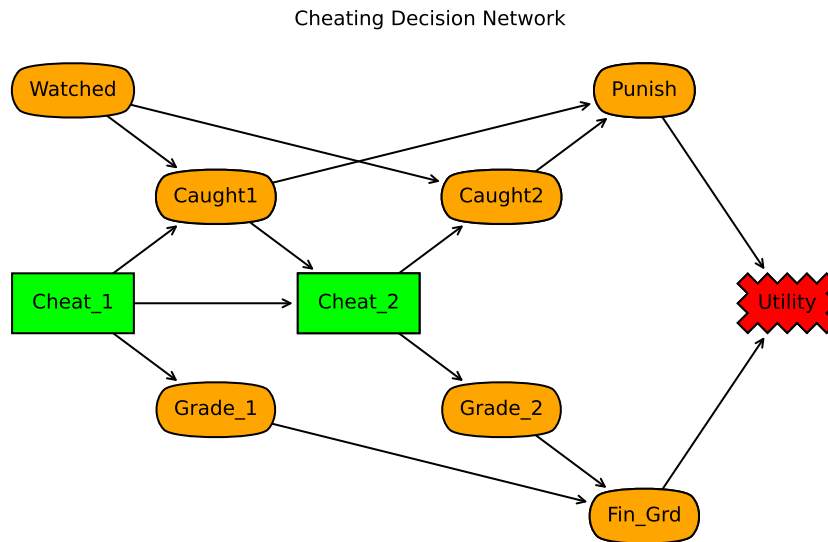

Figure 12.3: Cheating Decision Network (cheating_dn.show())

```

183 p_cc1 = Prob(Caught1,[Watched,Cheat_1],[[1.0, 0.0], [0.9, 0.1]],
184           [[1.0, 0.0], [0.5, 0.5]])
185 p_cc2 = Prob(Caught2,[Watched,Cheat_2],[[1.0, 0.0], [0.9, 0.1]],
186           [[1.0, 0.0], [0.5, 0.5]])
187 p_pun = Prob(Punish,[Caught1,Caught2],
188           [{"None":0,"Suspension":0,"Recorded":0},
189            {"None":0.5,"Suspension":0.4,"Recorded":0.1}],
190           [{"None":0.6,"Suspension":0.2,"Recorded":0.2},
191            {"None":0.2,"Suspension":0.3,"Recorded":0.3}])
192 p_gr1 = Prob(Grade_1,[Cheat_1], [{'A':0.2, 'B':0.3, 'C':0.3, 'F': 0.2},
193           {'A':0.5, 'B':0.3, 'C':0.2, 'F':0.0}])
194 p_gr2 = Prob(Grade_2,[Cheat_2], [{'A':0.2, 'B':0.3, 'C':0.3, 'F': 0.2},
195           {'A':0.5, 'B':0.3, 'C':0.2, 'F':0.0}])
196 p_fg = Prob(Fin_Grd,[Grade_1,Grade_2],
197           {'A':{'A':{'A':1.0, 'B':0.0, 'C': 0.0, 'F':0.0},
198             'B': {'A':0.5, 'B':0.5, 'C': 0.0, 'F':0.0},
199             'C':{'A':0.25, 'B':0.5, 'C': 0.25, 'F':0.0},
200             'F':{'A':0.25, 'B':0.25, 'C': 0.25, 'F':0.25}},
201            'B':{'A':{'A':0.5, 'B':0.5, 'C': 0.0, 'F':0.0},
202             'B': {'A':0.0, 'B':1, 'C': 0.0, 'F':0.0},
203             'C':{'A':0.0, 'B':0.5, 'C': 0.5, 'F':0.0},
204             'F':{'A':0.0, 'B':0.25, 'C': 0.5, 'F':0.25}},
205            'C':{'A':{'A':0.25, 'B':0.5, 'C': 0.25, 'F':0.0},
206             'B': {'A':0.0, 'B':0.5, 'C': 0.5, 'F':0.0},

```

```

207         'C': {'A': 0.0, 'B': 0.0, 'C': 1, 'F': 0.0},
208         'F': {'A': 0.0, 'B': 0.0, 'C': 0.5, 'F': 0.5}},
209     'F': {'A': {'A': 0.25, 'B': 0.25, 'C': 0.25, 'F': 0.25},
210           'B': {'A': 0.0, 'B': 0.25, 'C': 0.5, 'F': 0.25},
211           'C': {'A': 0.0, 'B': 0.0, 'C': 0.5, 'F': 0.5},
212           'F': {'A': 0.0, 'B': 0.0, 'C': 0, 'F': 1.0}}})
213
214 utc = UtilityTable([Punish, Fin_Grd],
215                   {'None': {'A': 100, 'B': 90, 'C': 70, 'F': 50},
216                     'Suspension': {'A': 40, 'B': 20, 'C': 10, 'F': 0},
217                     'Recorded': {'A': 70, 'B': 60, 'C': 40, 'F': 20}},
218                   position=(1, 0.5))
219
220 cheating_dn = DecisionNetwork("Cheating Decision Network",
221                               {Punish, Caught2, Watched, Fin_Grd, Grade_2, Grade_1, Cheat_2, Caught1, Cheat_1},
222                               {p_wa, p_cc1, p_cc2, p_pun, p_gr1, p_gr2, p_fg, utc})
223
224 # cheating_dn.show()
225 # cheating_dn.show(fontsize=15)

```

Chain of 3 decisions

The following decision network represents a finite-stage fully-observable Markov decision process with a single reward (utility) at the end. It is interesting because the parents do not include all the predecessors. The methods we use will work without change on this, even though the agent does not condition on all of its previous observations and actions. The output of `ch3.show()` is shown in Figure 12.4.

```

----- decnNetworks.py — (continued) -----
227 S0 = Variable('S0', boolean, position=(0,0.5))
228 D0 = DecisionVariable('D0', boolean, {S0}, position=(1/7,0.1))
229 S1 = Variable('S1', boolean, position=(2/7,0.5))
230 D1 = DecisionVariable('D1', boolean, {S1}, position=(3/7,0.1))
231 S2 = Variable('S2', boolean, position=(4/7,0.5))
232 D2 = DecisionVariable('D2', boolean, {S2}, position=(5/7,0.1))
233 S3 = Variable('S3', boolean, position=(6/7,0.5))
234
235 p_s0 = Prob(S0, [], [0.5,0.5])
236 tr = [[[0.1, 0.9], [0.9, 0.1]], [[0.2, 0.8], [0.8, 0.2]]] # 0 is flip, 1
      is keep value
237 p_s1 = Prob(S1, [D0,S0], tr)
238 p_s2 = Prob(S2, [D1,S1], tr)
239 p_s3 = Prob(S3, [D2,S2], tr)
240
241 ch3U = UtilityTable([S3],[0,1], position=(7/7,0.9))
242
243 ch3 = DecisionNetwork("3-chain",
      {S0,D0,S1,D1,S2,D2,S3},{p_s0,p_s1,p_s2,p_s3,ch3U})

```

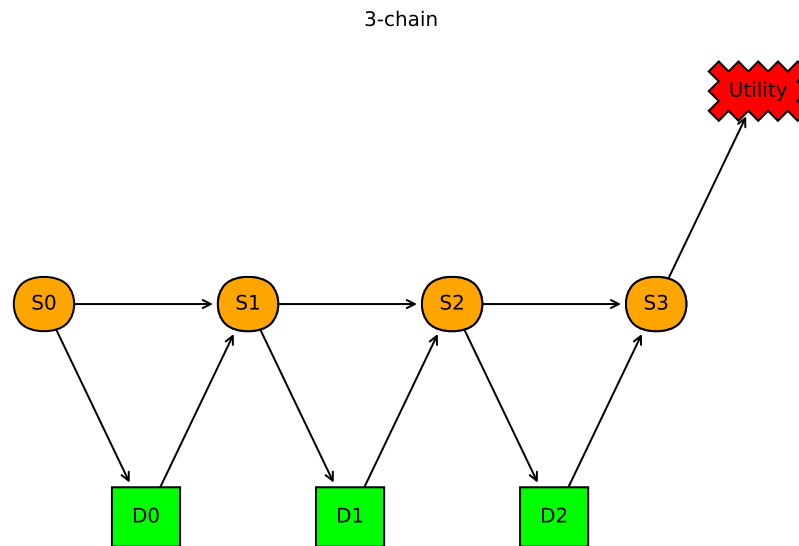

Figure 12.4: A decision network that is a chain of 3 decisions (`ch3.show()`)

```

244
245 # ch3.show()
246 # ch3.show(fontsize=15)

```

12.1.2 Decision Functions

The output of an optimization function is an optimal policy and its expected value. A policy is a list of decision functions. A decision function is the action for each decision variable as a function of its parents.

Let's represent the factor for a decision function as a dictionary.

```

-----decnNetworks.py --- (continued) -----
248 class DictFactor(Factor):
249     """A factor that represents its values using a dictionary"""
250     def __init__(self, *pargs, **kwargs):
251         self.values = {}
252         Factor.__init__(self, *pargs, **kwargs)
253
254     def assign(self, assignment, value):
255         self.values[frozenset(assignment.items())] = value
256
257     def get_value(self, assignment):
258         ass = frozenset(assignment.items())

```

```

259         assert ass in self.values, f"assignment {assignment} cannot be
           evaluated"
260         return self.values[ass]
261
262 class DecisionFunction(DictFactor):
263     def __init__(self, decision, parents):
264         """ A decision function
265         decision is a decision variable
266         parents is a set of variables
267         """
268         self.decision = decision
269         self.parent = parents
270         DictFactor.__init__(self, parents, name=decision.name)

```

12.1.3 Recursive Conditioning for Decision Networks

An instance of a RC_DN object takes in a decision network. The query method uses recursive conditioning to compute the expected utility of the optimal policy. When it is finished, `self.opt_policy` is the optimal policy.

```

----- decnNetworks.py --- (continued) -----
272 import math
273 from display import Displayable
274 from probGraphicalModels import GraphicalModel
275 from probFactors import Factor
276 from probRC import connected_components
277
278 class RC_DN(Displayable):
279     """The class that finds the optimal policy for a decision network.
280
281     dn is graphical model to query
282     """
283
284     def __init__(self, dn):
285         self.dn = dn
286         self.cache = {(frozenset(), frozenset()):1}
287         ## self.max_display_level = 3
288
289     def optimize(self, split_order=None, algorithm=None):
290         """computes expected utility, and creates optimal decision
           functions, where
291         elim_order is a list of the non-observed non-query variables in dn
292         algorithm is the (search algorithm to use). Default is self.rc
293         """
294         if algorithm is None:
295             algorithm = self.rc
296         if split_order == None:
297             split_order = self.dn.split_order()
298         self.opt_policy = {v:DecisionFunction(v, v.parents)
299                           for v in self.dn.variables}

```

```

300         if isinstance(v,DecisionVariable)}
301     return algorithm({}, self.dn.factors, split_order)
302
303     def show_policy(self):
304         print('\\n'.join(df.to_table() for df in self.opt_policy.values()))

```

The following is the simplest search-based algorithm. It is exponential in the number of variables, so is not very useful. However, it is simple, and helpful to understand before looking at the more complicated algorithm. Note that the above code does not call `rc0`; you will need to change the `self.rc` to `self.rc0` in above code to use it.

```

-----decnNetworks.py --- (continued)-----
306     def rc0(self, context, factors, split_order):
307         """simplest search algorithm
308         context is a variable:value dictionary
309         factors is a set of factors
310         split_order is a list of variables in factors that are not in
311             context
312         """
313         self.display(3,"calling rc0,", (context,factors),"with
314             S0",split_order)
315         if not factors:
316             return 1
317         elif to_eval := {fac for fac in factors if
318             fac.can_evaluate(context)}:
319             self.display(3,"rc0 evaluating factors",to_eval)
320             val = math.prod(fac.get_value(context) for fac in to_eval)
321             return val * self.rc0(context, factors-to_eval, split_order)
322         else:
323             var = split_order[0]
324             self.display(3, "rc0 branching on", var)
325             if isinstance(var,DecisionVariable):
326                 assert set(context) <= set(var.parents), f"cannot optimize
327                     {var} in context {context}"
328                 maxres = -math.inf
329                 for val in var.domain:
330                     self.display(3,"In rc0, branching on",var,"=",val)
331                     newres = self.rc0({var:val}|context, factors,
332                         split_order[1:])
333                     if newres > maxres:
334                         maxres = newres
335                         theval = val
336                     self.opt_policy[var].assign(context,theval)
337                 return maxres
338             else:
339                 total = 0
340                 for val in var.domain:
341                     total += self.rc0({var:val}|context, factors,
342                         split_order[1:])
343                 self.display(3, "rc0 branching on", var,"returning", total)

```

```
338 |         return total
```

We can combine the optimization for decision networks above, with the improvements of recursive conditioning used for graphical models (Section 9.7, page 246).

```

decnNetworks.py — (continued)
340 | def rc(self, context, factors, split_order):
341 |     """ returns the number sum_{split_order} prod_{factors} given
           assignments in context
342 |     context is a variable:value dictionary
343 |     factors is a set of factors
344 |     split_order is a list of variables in factors that are not in
           context
345 |     """
346 |     self.display(3,"calling rc,", (context,factors))
347 |     ce = (frozenset(context.items()), frozenset(factors)) # key for the
           cache entry
348 |     if ce in self.cache:
349 |         self.display(2,"rc cache lookup", (context,factors))
350 |         return self.cache[ce]
351 | #     if not factors: # no factors; needed if you don't have forgetting
           and caching
352 | #         return 1
353 |     elif vars_not_in_factors := {var for var in context
           if not any(var in fac.variables for
354 |                    fac in factors)}:
355 |         # forget variables not in any factor
356 |         self.display(3,"rc forgetting variables", vars_not_in_factors)
357 |         return self.rc({key:val for (key,val) in context.items()
           if key not in vars_not_in_factors},
358 |                        factors, split_order)
359 |     elif to_eval := {fac for fac in factors if
           fac.can_evaluate(context)}:
360 |         # evaluate factors when all variables are assigned
361 |         self.display(3,"rc evaluating factors",to_eval)
362 |         val = math.prod(fac.get_value(context) for fac in to_eval)
363 |         if val == 0:
364 |             return 0
365 |         else:
366 |             return val * self.rc(context, {fac for fac in factors if fac
           not in to_eval}, split_order)
367 |     elif len(comp := connected_components(context, factors,
           split_order)) > 1:
368 |         # there are disconnected components
369 |         self.display(2,"splitting into connected components",comp)
370 |         return(math.prod(self.rc(context,f,eo) for (f,eo) in comp))
371 |     else:
372 |         assert split_order, f"split_order empty rc({context},{factors})"
373 |         var = split_order[0]
374 |         self.display(3, "rc branching on", var)
375 |

```

```

376         if isinstance(var,DecisionVariable):
377             assert set(context) <= set(var.parents), f"cannot optimize
                 {var} in context {context}"
378             maxres = -math.inf
379             for val in var.domain:
380                 self.display(3,"In rc, branching on",var,"=",val)
381                 newres = self.rc({var:val}|context, factors,
                 split_order[1:])
382                 if newres > maxres:
383                     maxres = newres
384                     theval = val
385                 self.opt_policy[var].assign(context,theval)
386                 self.cache[ce] = maxres
387             return maxres
388         else:
389             total = 0
390             for val in var.domain:
391                 total += self.rc({var:val}|context, factors,
                 split_order[1:])
392             self.display(3, "rc branching on", var,"returning", total)
393             self.cache[ce] = total
394             return total

```

Here is how to run the optimizer on the example decision networks:

```

-----decnNetworks.py --- (continued) -----
396 # Umbrella decision network
397 #urc = RC_DN(umbrella_dn)
398 #urc.optimize(algorithm=urc.rc0) #RC0
399 #urc.optimize() #RC
400 #urc.show_policy()
401
402 #rc_fire = RC_DN(fire_dn)
403 #rc_fire.optimize()
404 #rc_fire.show_policy()
405
406 #rc_cheat = RC_DN(cheating_dn)
407 #rc_cheat.optimize()
408 #rc_cheat.show_policy()
409
410 #rc_ch3 = RC_DN(ch3)
411 #rc_ch3.optimize()
412 #rc_ch3.show_policy()
413 # rc_ch3.optimize(algorithm=rc_ch3.rc0) # why does that happen?

```

12.1.4 Variable elimination for decision networks

VE_DN is variable elimination for decision networks. The method *optimize* is used to optimize all the decisions. Note that *optimize* requires a legal elimination ordering of the random and decision variables, otherwise it will give an

exception. (A decision node can only be maximized if the variables that are not its parents have already been eliminated.)

```

415 from probVE import VE
416
417 class VE_DN(VE):
418     """Variable Elimination for Decision Networks"""
419     def __init__(self, dn=None):
420         """dn is a decision network"""
421         VE.__init__(self, dn)
422         self.dn = dn
423
424     def optimize(self, elim_order=None, obs={}):
425         if elim_order == None:
426             elim_order = reversed(self.dn.split_order())
427         self.opt_policy = {}
428         proj_factors = [self.project_observations(fac, obs)
429                         for fac in self.dn.factors]
430         for v in elim_order:
431             if isinstance(v, DecisionVariable):
432                 to_max = [fac for fac in proj_factors
433                           if v in fac.variables and set(fac.variables) <=
434                               v.all_vars]
435                 assert len(to_max)==1, "illegal variable order
436                    "+str(elim_order)+" at "+str(v)
437                 newFac = FactorMax(v, to_max[0])
438                 self.opt_policy[v]=newFac.decision_fun
439                 proj_factors = [fac for fac in proj_factors if fac is not
440                               to_max[0]]+[newFac]
441                 self.display(2, "maximizing", v )
442                 self.display(3, newFac)
443             else:
444                 proj_factors = self.eliminate_var(proj_factors, v)
445         assert len(proj_factors)==1, "Should there be only one element of
446            proj_factors?"
447         return proj_factors[0].get_value({})
448
449     def show_policy(self):
450         print('\n'.join(df.to_table() for df in self.opt_policy.values()))

```

```

448 class FactorMax(TabFactor):
449     """A factor obtained by maximizing a variable in a factor.
450     Also builds a decision_function. This is based on FactorSum.
451     """
452
453     def __init__(self, dvar, factor):
454         """dvar is a decision variable.
455         factor is a factor that contains dvar and only parents of dvar

```

```

456     """
457     self.dvar = dvar
458     self.factor = factor
459     vars = [v for v in factor.variables if v is not dvar]
460     Factor.__init__(self,vars)
461     self.values = {}
462     self.decision_fun = DecisionFunction(dvar, dvar.parents)
463
464     def get_value(self,assignment):
465         """lazy implementation: if saved, return saved value, else compute
466            it"""
467         new_asst = {x:v for (x,v) in assignment.items() if x in
468                     self.variables}
469         asst = frozenset(new_asst.items())
470         if asst in self.values:
471             return self.values[asst]
472         else:
473             max_val = float("-inf") # -infinity
474             for elt in self.dvar.domain:
475                 fac_val = self.factor.get_value(assignment|{self.dvar:elt})
476                 if fac_val>max_val:
477                     max_val = fac_val
478                     best_elt = elt
479             self.values[asst] = max_val
480             self.decision_fun.assign(assignment, best_elt)
481             return max_val

```

Here are some example queries:

```

decnNetworks.py — (continued)
481 # Example queries:
482 # vf = VE_DN(fire_dn)
483 # vf.optimize()
484 # vf.show_policy()
485
486 # VE_DN.max_display_level = 3 # if you want to show lots of detail
487 # vc = VE_DN(cheating_dn)
488 # vc.optimize()
489 # vc.show_policy()
490
491 def test(dn):
492     rc0dn = RC_DN(dn)
493     rc0v = rc0dn.optimize(algorithm=rc0dn.rc0)
494     rcdn = RC_DN(dn)
495     rcv = rcdn.optimize()
496     assert abs(rc0v-rcv)<1e-10, f"rc0 produces {rc0v}; rc produces {rcv}"
497     vedn = VE_DN(dn)
498     vev = vedn.optimize()
499     assert abs(vev-rcv)<1e-10, f"VE_DN produces {vev}; RC produces {rcv}"
500     print(f"passed unit test. rc0, rc and VE gave same result for {dn}")
501

```

```

502 | if __name__ == "__main__":
503 |     test(fire_dn)

```

12.2 Markov Decision Processes

The following represent a **Markov decision process (MDP)** directly, rather than using the recursive conditioning or variable elimination code.

```

_____mdpProblem.py — Representations for Markov Decision Processes_____
11 | import random
12 | from display import Displayable
13 | from utilities import argmaxd
14 |
15 | class MDP(Displayable):
16 |     """A Markov Decision Process. Must define:
17 |     title a string that gives the title of the MDP
18 |     states the set (or list) of states
19 |     actions the set (or list) of actions
20 |     discount a real-valued discount
21 |     """
22 |
23 |     def __init__(self, title, states, actions, discount, init=0):
24 |         self.title = title
25 |         self.states = states
26 |         self.actions = actions
27 |         self.discount = discount
28 |         self.inity = self.V = {s:init for s in self.states}
29 |         self.initq = self.Q = {s: {a: init for a in self.actions} for s in
30 |             self.states}
31 |
32 |     def P(self,s,a):
33 |         """Transition probability function
34 |         returns a dictionary of {s1:p1} such that P(s1 | s,a)=p1,
35 |         and other probabilities are zero.
36 |         """
37 |         raise NotImplementedError("P") # abstract method
38 |
39 |     def R(self,s,a):
40 |         """Reward function R(s,a)
41 |         returns the expected reward for doing a in state s.
42 |         """
43 |         raise NotImplementedError("R") # abstract method

```

Two state partying example (Example 12.29 in Poole and Mackworth [2023]):

```

_____mdpExamples.py — MDP Examples_____
11 | from mdpProblem import MDP, ProblemDomain, distribution
12 | from mdpGUI import GridDomain

```

```

13 import matplotlib.pyplot as plt
14
15 class partyMDP(MDP):
16     """Simple 2-state, 2-Action Partying MDP Example"""
17     def __init__(self, discount=0.9):
18         states = {'healthy', 'sick'}
19         actions = {'relax', 'party'}
20         MDP.__init__(self, "party MDP", states, actions, discount)
21
22     def R(self,s,a):
23         "R(s,a)"
24         return { 'healthy': {'relax': 7, 'party': 10},
25                 'sick':   {'relax': 0, 'party': 2 }}[s][a]
26
27     def P(self,s,a):
28         "returns a dictionary of {s1:p1} such that P(s1 | s,a)=p1. Other
29         probabilities are zero."
30         phealthy = { # P('healthy' | s, a)
31                     'healthy': {'relax': 0.95, 'party': 0.7},
32                     'sick':   {'relax': 0.5, 'party': 0.1 }}[s][a]
33         return {'healthy':phealthy, 'sick':1-phealthy}

```

The distribution class is used to represent distributions as they are being created. Probability distributions are represented as *item : value* dictionaries. When being constructed, adding an *item : value* to the dictionary has to act differently when the item is already in the dictionary and when it isn't. The `add_prob` method works whether the item is in the dictionary or not.

mdpProblem.py — (continued)

```

44 class distribution(dict):
45     """A distribution is an item:prob dictionary.
46     Probabilities are added using add_prop.
47     """
48     def __init__(self,d):
49         dict.__init__(self,d)
50
51     def add_prob(self, item, pr):
52         """adds a probability to a distribution.
53         Like dictionary assignment, but if item is already there, the
54         values are summed
55         """
56         if item in self:
57             self[item] += pr
58         else:
59             self[item] = pr
60         return self

```

12.2.1 Problem Domains

An MDP does not contain enough information to simulate a domain, because

- (a) the rewards and resulting state can be correlated (e.g., in the grid domains below, crashing into a wall results in both a negative reward and the agent not moving), and
- (b) it represents the *expected* reward (e.g., a reward of 1 is has the same expected value as a reward of 100 with probability 1/100 and 0 otherwise, but these are different in a simulation).

A problem domain represents a problem as a function result from states and actions into a distribution of (*state, reward*) pairs. This can be a subclass of MDP because it implements R and P. A problem domain also specifies an initial state and coordinate information used by the graphical user interfaces.

```

_____mdpProblem.py — (continued) _____
61 class ProblemDomain(MDP):
62     """A ProblemDomain implements
63     self.result(state, action) -> {(reward, state):probability}.
64     Other pairs have probability are zero.
65     The probabilities must sum to 1.
66     """
67     def __init__(self, title, states, actions, discount,
68                 initial_state=None, x_dim=0, y_dim = 0,
69                 vinit=0, offsets={}):
70         """A problem domain
71         * title is list of titles
72         * states is the list of states
73         * actions is the list of actions
74         * discount is the discount factor
75         * initial_state is the state the agent starts at (for simulation)
76           if known
77         * x_dim and y_dim are the dimensions used by the GUI to show the
78           states in 2-dimensions
79         * vinit is the initial value
80         * offsets is a {action:(x,y)} map which specifies how actions are
81           displayed in GUI
82         """
83         MDP.__init__(self, title, states, actions, discount)
84         if initial_state is not None:
85             self.state = initial_state
86         else:
87             self.state = random.choice(states)
88         self.vinit = vinit # value to reset v,q to
89         # The following are for the GUI:
90         self.x_dim = x_dim
91         self.y_dim = y_dim
92         self.offsets = offsets
93
94     def state2pos(self, state):
95         """When displaying as a grid, this specifies how the state is
96           mapped to (x,y) position.
97         The default is for domains where the (x,y) position is the state

```

```

94         """
95         return state
96
97     def state2goal(self, state):
98         """When displaying as a grid, this specifies how the state is
99         mapped to goal position.
100         The default is for domains where there is no goal
101         """
102         return None
103
104     def pos2state(self, pos):
105         """When displaying as a grid, this specifies how the state is
106         mapped to (x,y) position.
107         The default is for domains where the (x,y) position is the state
108         """
109         return pos
110
111     def P(self, state, action):
112         """Transition probability function
113         returns a dictionary of {s1:p1} such that P(s1 | state,action)=p1.
114         Other probabilities are zero.
115         """
116         res = self.result(state, action)
117         acc = 1e-6 # accuracy for test of equality
118         assert 1-acc<sum(res.values())<1+acc, f"result({state},{action})
119         not a distribution, sum={sum(res.values())}"
120         dist = distribution({})
121         for ((r,s),p) in res.items():
122             dist.add_prob(s,p)
123         return dist
124
125     def R(self, state, action):
126         """Reward function R(s,a)
127         returns the expected reward for doing a in state s.
128         """
129         return sum(r*p for ((r,s),p) in self.result(state, action).items())

```

Tiny Game

The next example is the tiny game from Example 13.1 and Figure 13.1 of Poole and Mackworth [2023], shown here as Figure 12.5. There are 6 states and 4 actions. The state is represented as (x,y) where x counts from zero from the left, and y counts from zero upwards, so the state $(0,0)$ is on the bottom-left. The actions are upC for up-careful, upR for up-risky, left, and right. Going left from $(0,2)$ results in a reward of 10 and ending up in state $(0,0)$; going left from $(0,1)$ results in a reward of -100 and staying there. Up-risky goes up but with a chance of going left or right. Up careful goes up, but has a reward of -1 . Left and right are deterministic. Crashing into a wall results in a reward of -1 and staying still.

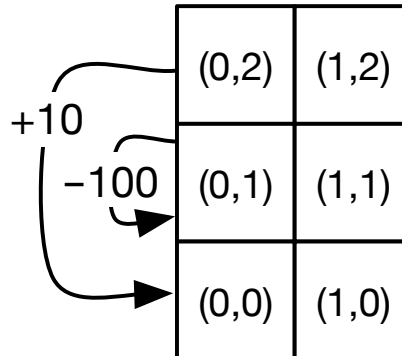

Figure 12.5: Tiny game

(Note that GridDomain means that it can be shown with the MDP GUI in Section 12.2.3).

```

mdpExamples.py — (continued)
34 class MDPTiny(ProblemDomain, GridDomain):
35     def __init__(self, discount=0.9):
36         x_dim = 2 # x-dimension
37         y_dim = 3
38         ProblemDomain.__init__(self,
39             "Tiny MDP", # title
40             [(x,y) for x in range(x_dim) for y in range(y_dim)], #states
41             ['right', 'upC', 'left', 'upR'], #actions
42             discount,
43             x_dim=x_dim, y_dim = y_dim,
44             offsets = {'right':(0.25,0), 'upC':(0,-0.25), 'left':(-0.25,0),
45                       'upR':(0,0.25)}
46         )
47     def result(self, state, action):
48         """return a dictionary of {(r,s):p} where p is the probability of
49         reward r, state s
50         a state is an (x,y) pair
51         """
52         (x,y) = state
53         right = (-x,(1,y)) # reward is -1 if x was 1
54         left = (0,(0,y)) if x==1 else [(-1,(0,0)), (-100,(0,1)),
55                                       (10,(0,0))][y]
56         up = (0,(x,y+1)) if y<2 else (-1,(x,y))
57         if action == 'right':
58             return {right:1}
59         elif action == 'upC':
60             (r,s) = up

```

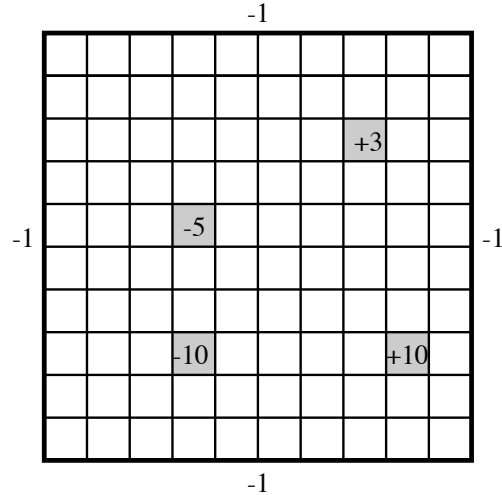

Figure 12.6: Grid world

```

59         return {(r-1,s):1}
60     elif action == 'left':
61         return {left:1}
62     elif action == 'upR':
63         return distribution({left:
64             0.1}).add_prob(right,0.1).add_prob(up,0.8)
65         # Exercise: what is wrong with return {left: 0.1, right:0.1,
66             up:0.8}
67
68 # To show GUI do
69 # MDPtiny().viGUI()

```

Grid World

Here is the domain of Example 12.30 of Poole and Mackworth [2023], shown here in Figure 12.6. A state is represented as (x,y) where x counts from zero from the left, and y counts from zero upwards, so the state $(0,0)$ is on the bottom-left.

```

_____mdpExamples.py — (continued)_____
69 class grid(ProblemDomain, GridDomain):
70     """ x_dim * y_dim grid with rewarding states"""
71     def __init__(self, discount=0.9, x_dim=10, y_dim=10):
72         ProblemDomain.__init__(self,
73             "Grid World",
74             [(x,y) for x in range(y_dim) for y in range(y_dim)], #states
75             ['up', 'down', 'right', 'left'], #actions
76             discount,
77             x_dim = x_dim, y_dim = y_dim,

```

```

78         offsets = {'right':(0.25,0), 'up':(0,0.25), 'left':(-0.25,0),
79                   'down':(0,-0.25)})
80     self.rewarding_states = {(3,2):-10, (3,5):-5, (8,2):10, (7,7):3 }
81     self.fling_states = {(8,2), (7,7)} # assumed a subset of
82         rewarding_states
83
84     def intended_next(self,s,a):
85         """returns the (reward, state) in the direction a.
86         This is where the agent will end up if to goes in its
87         intended_direction
88         (which it does with probability 0.7).
89         """
90         (x,y) = s
91         if a=='up':
92             return (0, (x,y+1)) if y+1 < self.y_dim else (-1, (x,y))
93         if a=='down':
94             return (0, (x,y-1)) if y > 0 else (-1, (x,y))
95         if a=='right':
96             return (0, (x+1,y)) if x+1 < self.x_dim else (-1, (x,y))
97         if a=='left':
98             return (0, (x-1,y)) if x > 0 else (-1, (x,y))
99
100     def result(self,s,a):
101         """return a dictionary of {(r,s):p} where p is the probability of
102         reward r, state s.
103         a state is an (x,y) pair
104         """
105         r0 = self.rewarding_states[s] if s in self.rewarding_states else 0
106         if s in self.fling_states:
107             return {(r0,(0,0)): 0.25, (r0,(self.x_dim-1,0)):0.25,
108                     (r0,(0,self.y_dim-1)):0.25,
109                     (r0,(self.x_dim-1,self.y_dim-1)):0.25}
110         dist = distribution({})
111         for a1 in self.actions:
112             (r1,s1) = self.intended_next(s,a1)
113             rs = (r1+r0, s1)
114             p = 0.7 if a1==a else 0.1
115             dist.add_prob(rs,p)
116         return dist

```

Figure 12.7 shows the immediate expected reward for each of the 100 states. This was generated using `grid().viGUI()` and carrying out one step.

Monster Game

This is for the game depicted in Figure 12.8 (Example 13.2 of Poole and Mackworth [2023]). There are 25 locations where the agent can be, there can be no prize or there can be a prize in one of the corners ($P_1 \dots P_4$). The agent only gets a positive reward when gets to the prize. The agent can be damaged or undamaged. There are possible monsters at the locations marked with M . If

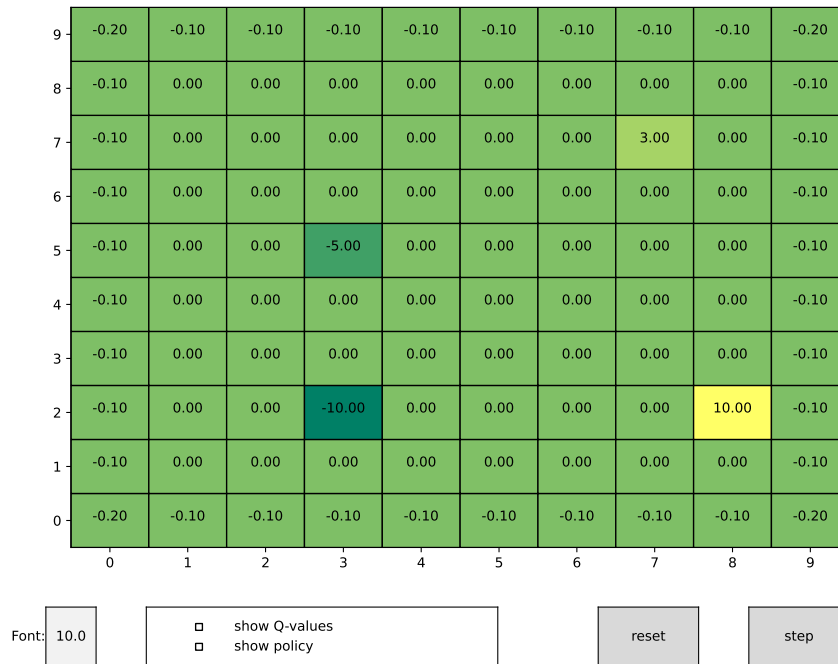
Figure 12.7: Grid world GUI: `grid().viGUI()`

the agent lands on a monster when it is undamaged, it gets damaged. If the agent lands on a monster when it is damaged, it gets a negative reward. It can get undamaged by going to the location marked with *R*. It gets a negative reward by crashing into a wall. There are $25 * 5 * 2 = 250$ states. There are 4 actions, *up*, *down*, *left*, and *right*; the agent generally goes in the direction of the action, but has a chance of going in one of the other directions.

mdpExamples.py — (continued)

```

113 class Monster_game(ProblemDomain, GridDomain):
114
115     vwalls = [(0,3), (0,4), (1,4)] # vertical walls right of these locations
116     crash_reward = -1
117
118     prize_locs = [(0,0), (0,4), (4,0), (4,4)]
119     prize_appears_prob = 0.3
120     prize_reward = 10
121
122     monster_locs = [(0,1), (1,1), (2,3), (3,1), (4,2)]
123     monster_appears_prob = 0.4
124     monster_reward_when_damaged = -10
125     repair_stations = [(1,4)]

```

4	P ₁	R			P ₂
3			M		
2					M
1	M	M		M	
0	P ₃				P ₄
	0	1	2	3	4

Figure 12.8: Monster game

```

126
127 def __init__(self, discount=0.9):
128     x_dim = 5
129     y_dim = 5
130     # which damaged and prize to show
131     ProblemDomain.__init__(self,
132         "Monster Game",
133         [(x,y,damaged,prize)
134             for x in range(x_dim)
135             for y in range(y_dim)
136             for damaged in [False,True]
137             for prize in [None]+self.prize_locs], #states
138         ['up', 'down', 'right', 'left'], #actions
139         discount,
140         x_dim = x_dim, y_dim = y_dim,
141         offsets = {'right':(0.25,0), 'up':(0,0.25), 'left':(-0.25,0),
142                 'down':(0,-0.25)})
142     self.state = (2,2,False,None)
143
144 def intended_next(self,xy,a):
145     """returns the (reward, (x,y)) in the direction a.
146     This is where the agent will end up if to goes in its
147     intended_direction
148     (which it does with probability 0.7).
149     """
149     (x,y) = xy # original x-y position
150     if a=='up':
151         return (0, (x,y+1)) if y+1 < self.y_dim else
152             (self.crash_reward, (x,y))
152     if a=='down':
153         return (0, (x,y-1)) if y > 0 else (self.crash_reward, (x,y))

```

```

154     if a=='right':
155         if (x,y) in self.vwalls or x+1==self.x_dim: # hit wall
156             return (self.crash_reward, (x,y))
157         else:
158             return (0, (x+1,y))
159     if a=='left':
160         if (x-1,y) in self.vwalls or x==0: # hit wall
161             return (self.crash_reward, (x,y))
162         else:
163             return (0, (x-1,y))
164
165     def result(self,s,a):
166         """return a dictionary of {(r,s):p} where p is the probability of
167         reward r, state s.
168         a state is an (x,y) pair
169         """
170         (x,y,damaged,prize) = s
171         dist = distribution({})
172         for a1 in self.actions: # possible results
173             mp = 0.7 if a1==a else 0.1
174             mr,(xn,yn) = self.intended_next((x,y),a1)
175             if (xn,yn) in self.monster_locs:
176                 if damaged:
177                     dist.add_prob((mr+self.monster_reward_when_damaged, (xn,yn,True,prize)),
178                                     mp*self.monster_appears_prob)
179                     dist.add_prob((mr, (xn,yn,True,prize)),
180                                     mp*(1-self.monster_appears_prob))
181                 else:
182                     dist.add_prob((mr, (xn,yn,True,prize)),
183                                     mp*self.monster_appears_prob)
184                     dist.add_prob((mr, (xn,yn,False,prize)),
185                                     mp*(1-self.monster_appears_prob))
186             elif (xn,yn) == prize:
187                 dist.add_prob((mr+self.prize_reward, (xn,yn,damaged,None)),
188                                     mp)
189             elif (xn,yn) in self.repair_stations:
190                 dist.add_prob((mr, (xn,yn,False,prize)), mp)
191             else:
192                 dist.add_prob((mr, (xn,yn,damaged,prize)), mp)
193         if prize is None:
194             res = distribution({})
195             for (r,(x2,y2,d,p2)),p in dist.items():
196                 res.add_prob((r, (x2,y2,d,None)),
197                                 p*(1-self.prize_appears_prob))
198             for pz in self.prize_locs:
199                 res.add_prob((r, (x2,y2,d,pz)),
200                                 p*self.prize_appears_prob/len(self.prize_locs))
201         return res
202     else:
203         return dist

```

```

196
197 def state2pos(self, state):
198     """When displaying as a grid, this specifies how the state is
199     mapped to (x,y) position.
200     The default is for domains where the (x,y) position is the state
201     """
202     (x,y,d,p) = state
203     return (x,y)
204
205 def pos2state(self, pos):
206     """When displaying as a grid, this specifies how the state is
207     mapped to (x,y) position.
208     """
209     (x,y) = pos
210     (xs, ys, damaged, prize) = self.state
211     return (x, y, damaged, prize)
212
213 def state2goal(self,state):
214     """the (x,y) position for the goal
215     """
216     (x, y, damaged, prize) = state
217     return prize
218
219 # value iteration GUI for Monster game:
220 # mg = Monster_game()
221 # mg.viGUI() # then run vi a few times
222 # to see other states, exit the GUI
223 # mg.state = (2,2,True,(4,4)) # or other damaged/prize states
224 # mg.viGUI()

```

12.2.2 Value Iteration

The following implements value iteration for Markov decision processes.

A Q function is represented as a dictionary so $Q[s][a]$ is the value for doing action a in state s . The value function is represented as a dictionary so $V[s]$ is the value of state s . Policy π is represented as a dictionary where $\pi[s]$, where s is a state, returns the action.

Note that the following defines `vi` to be a method in MDP.

```

_____mdpProblem.py — (continued)_____
128 def vi(self, n):
129     """carries out n iterations of value iteration, updating value
130     function self.V
131     Returns a Q-function, value function, policy
132     """
133     self.display(3,f"calling vi({n})")
134     for i in range(n):
135         self.Q = {s: {a: self.R(s,a)
136                     +self.discount*sum(p1*self.V[s1]

```

```

136         for (s1,p1) in
137             self.P(s,a).items()
138             for a in self.actions}
139         for s in self.states}
140         self.V = {s: max(self.Q[s][a] for a in self.actions)
141                 for s in self.states}
142         self.pi = {s: argmaxd(self.Q[s])
143                 for s in self.states}
144         return self.Q, self.V, self.pi
145 MDP.vi = vi

```

The following shows how this can be used.

```

----- mdpExamples.py — (continued) -----
224 ## Testing value iteration
225 # Try the following:
226 # pt = partyMDP(discount=0.9)
227 # pt.vi(1)
228 # pt.vi(100)
229 # partyMDP(discount=0.99).vi(100)
230 # partyMDP(discount=0.4).vi(100)
231
232 # gr = grid(discount=0.9)
233 # gr.viGUI()
234 # q,v,pi = gr.vi(100)
235 # q[(7,2)]

```

12.2.3 Value Iteration GUI for Grid Domains

A GridDomain is a domain where the states can be mapped into (x,y) positions, and the actions can be mapped into up-down-left-right. They are special because the `viGUI()` method to interact with them. It requires the following values/methods be defined:

- `self.x_dim` and `self.y_dim` define the dimensions of the grid (so the states are (x,y) , where $0 \leq x < \text{self.x_dim}$ and $0 \leq y < \text{self.y_dim}$).
- `self.state2pos(state)` gives the (x,y) position of state. The default is that that states are already (x,y) positions.
- `self.state2goal(state)` gives the (x,y) position of the goal in state. The default is None.
- `self.pos2state(pos)` where `pos` is an (x,y) pair, gives the state that is shown at position (x,y) . When the state contain more information than the (x,y) pair, the extra information is taken from `self.state`.
- `self.offsets[a]` defines where to display action `a`, as (x,y) offset for action `a` when displaying Q-values.

```

mdpGUI.py — GUI for value iteration in MDPs
11 import matplotlib.pyplot as plt
12 from matplotlib.widgets import Button, CheckButtons, TextBox
13 from mdpProblem import MDP
14
15 class GridDomain(object):
16
17     def viGUI(self):
18         fig,self.ax = plt.subplots()
19         plt.subplots_adjust(bottom=0.2)
20         stepB = Button(fig.add_axes([0.8,0.05,0.1,0.075]), "step")
21         stepB.on_clicked(self.on_step)
22         resetB = Button(fig.add_axes([0.65,0.05,0.1,0.075]), "reset")
23         resetB.on_clicked(self.on_reset)
24         self.qcheck = CheckButtons(fig.add_axes([0.2,0.05,0.35,0.075]),
25                                     ["show Q-values","show policy"])
26         self.qcheck.on_clicked(self.show_vals)
27         self.font_box = TextBox(fig.add_axes([0.1,0.05,0.05,0.075]),
28                                     "Font:", textalignment="center")
29         self.font_box.on_submit(self.set_font_size)
30         self.font_box.set_val(str(plt.rcParams['font.size']))
31         self.show_vals(None)
32         plt.show()
33
34     def set_font_size(self, s):
35         plt.rcParams.update({'font.size': eval(s)})
36         plt.draw()
37
38     def show_vals(self,event):
39         self.ax.cla() # clear the axes
40
41         array = [[self.V[self.pos2state((x,y))] for x in range(self.x_dim)]
42                 for y in range(self.y_dim)]
43         self.ax.pcolormesh([x-0.5 for x in range(self.x_dim+1)],
44                             [y-0.5 for y in range(self.y_dim+1)],
45                             array, edgecolors='black',cmap='summer')
46         # for cmap see
47         # https://matplotlib.org/stable/tutorials/colors/colormaps.html
48         if self.qcheck.get_status()[1]: # "show policy"
49             for x in range(self.x_dim):
50                 for y in range(self.y_dim):
51                     state = self.pos2state((x,y))
52                     maxv = max(self.Q[state][a] for a in self.actions)
53                     for a in self.actions:
54                         if self.Q[state][a] == maxv:
55                             # draw arrow in appropriate direction
56                             xoff, yoff = self.offsets[a]
57                             self.ax.arrow(x,y,xoff*2,yoff*2,
58                                             color='red',width=0.05, head_width=0.2,
59                                             length_includes_head=True)

```

```

59         if self.qcheck.get_status()[0]: # "show q-values"
60             self.show_q(event)
61         else:
62             self.show_v(event)
63             self.ax.set_xticks(range(self.x_dim))
64             self.ax.set_xticklabels(range(self.x_dim))
65             self.ax.set_yticks(range(self.y_dim))
66             self.ax.set_yticklabels(range(self.y_dim))
67             plt.draw()
68
69     def on_step(self, event):
70         self.step()
71         self.show_vals(event)
72
73     def step(self):
74         """The default step is one step of value iteration"""
75         self.vi(1)
76
77     def show_v(self, event):
78         """show values"""
79         for x in range(self.x_dim):
80             for y in range(self.y_dim):
81                 state = self.pos2state((x,y))
82                 self.ax.text(x,y,"{val:.2f}".format(val=self.V[state]),ha='center')
83
84     def show_q(self, event):
85         """show q-values"""
86         for x in range(self.x_dim):
87             for y in range(self.y_dim):
88                 state = self.pos2state((x,y))
89                 for a in self.actions:
90                     xoff, yoff = self.offsets[a]
91                     self.ax.text(x+xoff,y+yoff,
92                                 "{val:.2f}".format(val=self.Q[state][a]),ha='center')
93
94     def on_reset(self, event):
95         self.V = {s:self.vinit for s in self.states}
96         self.Q = {s: {a: self.vinit for a in self.actions} for s in
97                   self.states}
98         self.show_vals(event)
99
100 # to use the GUI do some of:
101 import mdpExamples
102 # mdpExamples.MDPtiny(discount=0.9).viGUI()
103 # mdpExamples.grid(discount=0.9).viGUI()
104 # mdpExamples.Monster_game(discount=0.9).viGUI() # see mdpExamples.py
105
106 if __name__ == "__main__":
107     print("Try: mdpExamples.MDPtiny(discount=0.9).viGUI()")

```

Figure 12.9 shows the user interface for the tiny domain, which can be ob-

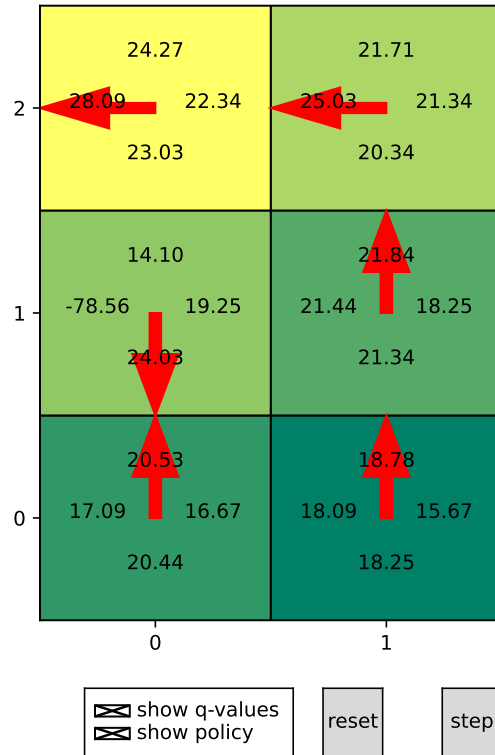

Figure 12.9: Interface for tiny example, after a number of steps. Each rectangle represents a state. In each rectangle are the 4 Q-values for the state. The left-most number is for the left action; the rightmost number is for the right action; the uppermost is for the *upR* (up-risky) action and the lowest number is for the *upC* action. The arrow points to the action(s) with the maximum Q-value. Use `MDPtiny().viGUI()` after loading `mdpExamples.py`

tained using

```
MDPtiny(discount=0.9).viGUI()
```

resizing it, checking “show q-values” and “show policy”, and clicking “step” a few times.

To run the demo in class do:

```
% python -i mdpExamples.py
MDPtiny(discount=0.9).viGUI()
```

Figure 12.10 shows the user interface for the grid domain, which can be obtained using

```
grid(discount=0.9).viGUI()
```

resizing it, checking “show q-values” and “show policy”, and clicking “step” a few times.

Figure 12.11 shows the optimal policy and Q-values after convergence (clicking “step” more does not change the Q-values) for the states where the agent is damaged and the goal is in the top-right. There are 10 times as many states as positions, so we can’t show them all. See the commented out lines at the end of the Monster game code to reproduce this figure.

Exercise 12.1 Computing q before v may seem like a waste of space because we don’t need to store q in order to compute the value function or the policy. Change the algorithm so that it loops through the states and actions once per iteration, and only stores the value function and the policy. Note that to get the same results as before, you would need to make sure that you use the previous value of v in the computation not the current value of v . Does using the current value of v hurt the algorithm or make it better (in approaching the actual value function)?

12.2.4 Asynchronous Value Iteration

This implements asynchronous value iteration, storing Q .

A Q function is represented using $Q[s][a]$ as the value for doing action with a in state s .

```

mdpProblem.py — (continued)
147 def avi(self,n):
148     states = list(self.states)
149     actions = list(self.actions)
150     for i in range(n):
151         s = random.choice(states)
152         a = random.choice(actions)
153         self.Q[s][a] = (self.R(s,a) + self.discount *
154                        sum(p1 * max(self.Q[s1][a1]
155                                   for a1 in self.actions)
156                             for (s1,p1) in self.P(s,a).items()))
157     return self.Q
158
159 # make this a method for the MPD class:
160 MDP.avi = avi

```

The following shows how `avi` can be used.

```

mdpExamples.py — (continued)
238 ## Testing asynchronous value iteration
239 # Try the following:
240 # pt = partyMDP(discount=0.9)
241 # pt.avi(10)
242 # pt.vi(1000)
243
244 # gr = grid(discount=0.9)
245 # q = gr.avi(100000)
246 # q[(7,2)]

```

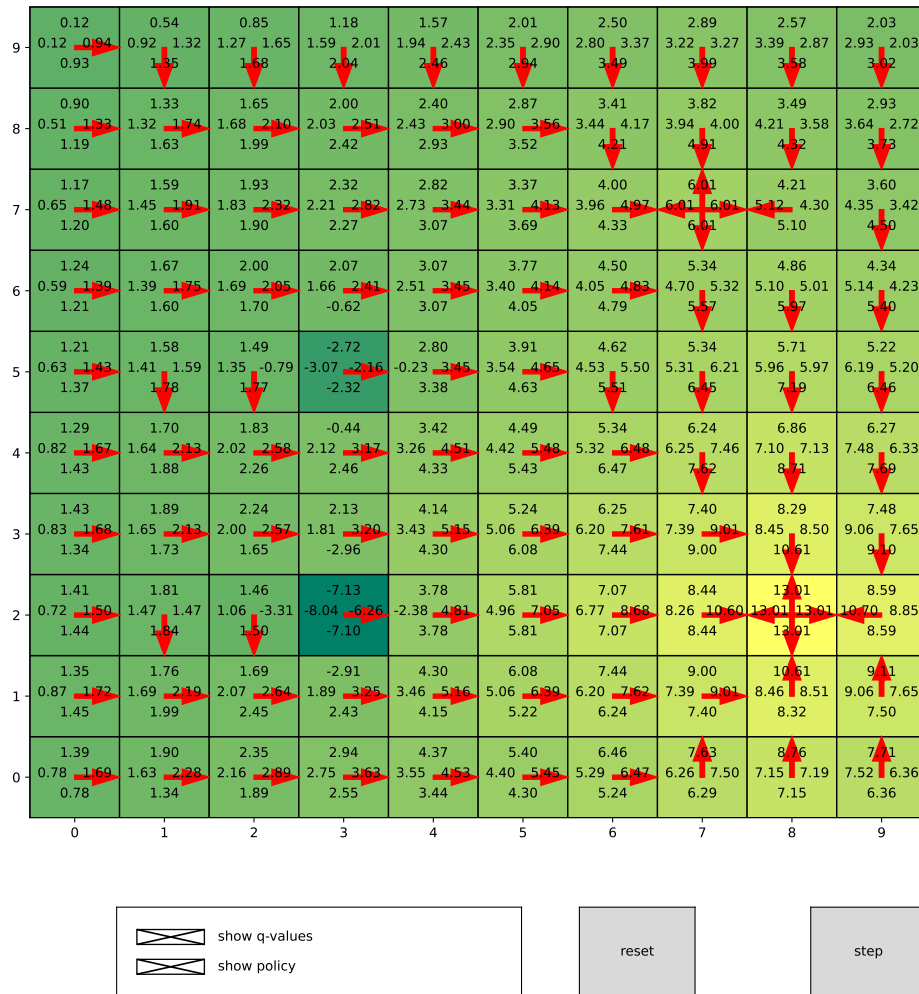

Figure 12.10: Interface for grid example, after a number of steps. Each rectangle represents a state. In each rectangle are the 4 Q-values for the state. The leftmost number is for the left action; the rightmost number is for the right action; the uppermost is for the up action and the lowest number is for the down action. The arrow points to the action(s) with the maximum Q-value. From `grid(discount=0.9).viGUI()`

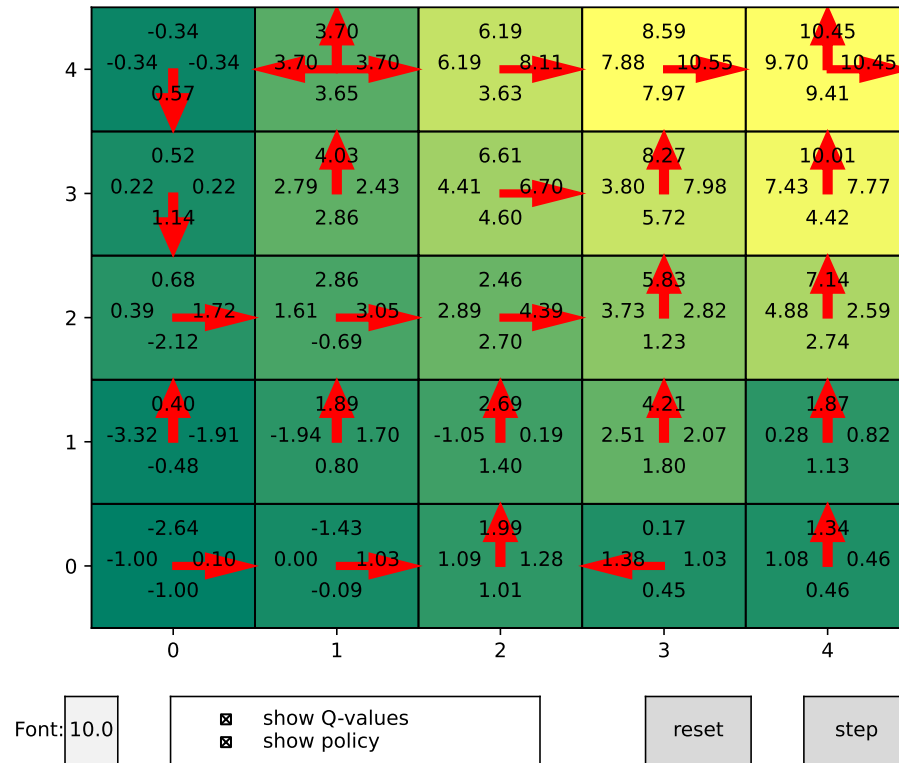

Figure 12.11: Q-values and optimal policy for the monster game, for the states where the agent is damaged and the goal is in the top-right.

```

247
248 def test_MDP(mdp, discount=0.9, eps=0.01):
249     """tests vi and avi give the same answer for a MDP class mdp
250     """
251     mdp1 = mdp(discount=discount)
252     q1,v1,p1 = mdp1.vi(100)
253     mdp2 = mdp(discount=discount)
254     q2 = mdp2.avi(1000)
255     same = all(abs(q1[s][a]-q2[s][a]) < eps
256                for s in mdp1.states
257                for a in mdp1.actions)
258     assert same, "vi and avi are different:\n{q1}\n{q2}"
259     print(f"passed unit test. vi and avi gave same result for {mdp1.title}")
260
261 if __name__ == "__main__":
262     test_MDP(partyMDP)

```

Exercise 12.2 Implement value iteration that stores the V -values rather than the Q -values. Does it work better than storing Q ? (What might “better” mean?)

Exercise 12.3 In asynchronous value iteration, try a number of different ways to choose the states and actions to update (e.g., sweeping through the state-action pairs, choosing them at random). Note that the best way may be to determine which states have had their Q -values changed the most, and then update the previous ones, but that is not so straightforward to implement, because you need to find those previous states.

Reinforcement Learning

13.1 Representing Agents and Environments

The reinforcement learning agents and environments are instances of the general agent architecture of Section 2.1, where the percepts are (reward, state) pairs. The state here is the state of the environment, not the state of the agent. Thus this is assuming that the environment is **fully observable**.

Agents are told what actions are available to it to use, but don't initially know anything about the possible states.

- An agent implements the method `select_action` takes a (reward, state) returns the next action (and updates the state of the agent).
- An environment implements the method `do` that takes an action and returns a (reward, state) pair.

These are alternated to simulate the system. The simulation starts with the agent choosing the initial action given the state, using the method `initial_action(state)`, which typically remembers the state and returns a random action.

13.1.1 Environments

RL environments have names to make tracing easier. An environment also has a list of all of the actions that can be carried out in the environment. It is initialized with the initial state.

```
_____rlProblem.py — Representations for Reinforcement Learning _____  
11 | import random  
12 | import math  
13 | from display import Displayable
```

```

14 from agents import Agent, Environment
15 from utilities import select_from_dist, argmaxe, argmaxd, flip
16
17 class RL_env(Environment):
18     def __init__(self, name, actions, state):
19         """creates an environment given name, list of actions, and initial
20            state"""
21         self.name = name          # the name of the environment
22         self.actions = actions    # list of all actions
23         self.state = state        # initial state
24         self.reward = None        # last reward
25
26     # must implement do(action)->(reward,state)

```

13.1.2 Agents

An agent initially knows what actions it can carry out (its abilities). The interactions is started by calling `initial_action`, which tells the agent what the initial state is. An agent typically remembers the state and returns an action. It has no reason to prefer one action over another, so it chooses an action at random.

```

-----rIProblem.py --- (continued)-----
27 class RL_agent(Agent):
28     """An RL_Agent
29     has percepts (s, r) for some state s and real reward r
30     """
31     def __init__(self, actions):
32         self.actions = actions
33
34     def initial_action(self, env_state):
35         """return the initial action, and remember the state and action
36         Act randomly initially
37         Could be overridden to initialize data structures (as the agent now
38            knows about one state)
39         """
40         self.state = env_state
41         self.action = random.choice(self.actions)
42         return self.action

```

At each time step, an agent selects its next action `action` given the reward it received and the environment.

```

-----rIProblem.py --- (continued)-----
43     def select_action(self, reward, state):
44         """
45         Select the action given the reward and state
46         Remember the action in self.action
47         This implements "Act randomly" and should be overridden!
48         """

```

```

49     self.reward = reward
50     self.action = random.choice(self.actions)
51     return self.action
52
53     def v(self, state):
54         """estimate of the value of doing a best action in state.
55         """
56         return max(self.q(state,a) for a in self.actions)
57
58     def q(self, state, action):
59         """estimate of value of doing action in state. Should be
60         overridden to be useful.
61         """
62         return 0

```

13.1.3 Simulating an Environment-Agent Interaction

The interaction between an agent and an environment is mediated by a simulator that calls the agent and the environment in turn. Simulate in this section is similar to Simulate of Section 2.1, except it is initialized by `agent.initial_action(state)`, and the rewards are accumulated.

```

_____rlProblem.py — (continued)_____
63 import matplotlib.pyplot as plt
64
65 class Simulate(Displayable):
66     """simulate the interaction between the agent and the environment
67     for n time steps.
68     Returns a pair of the agent state and the environment state.
69     """
70     def __init__(self, agent, environment):
71         self.agent = agent
72         self.env = environment
73         self.reward_history = [] # for plotting
74         self.step = 0
75         self.sum_rewards = 0
76
77     def start(self):
78         self.action = self.agent.initial_action(self.env.state)
79         return self
80
81     def go(self, n):
82         for i in range(n):
83             self.step += 1
84             (reward,state) = self.env.do(self.action)
85             self.display(2,f"step={self.step} reward={reward},
86                 state={state}")
87             self.sum_rewards += reward
88             self.reward_history.append(reward)

```

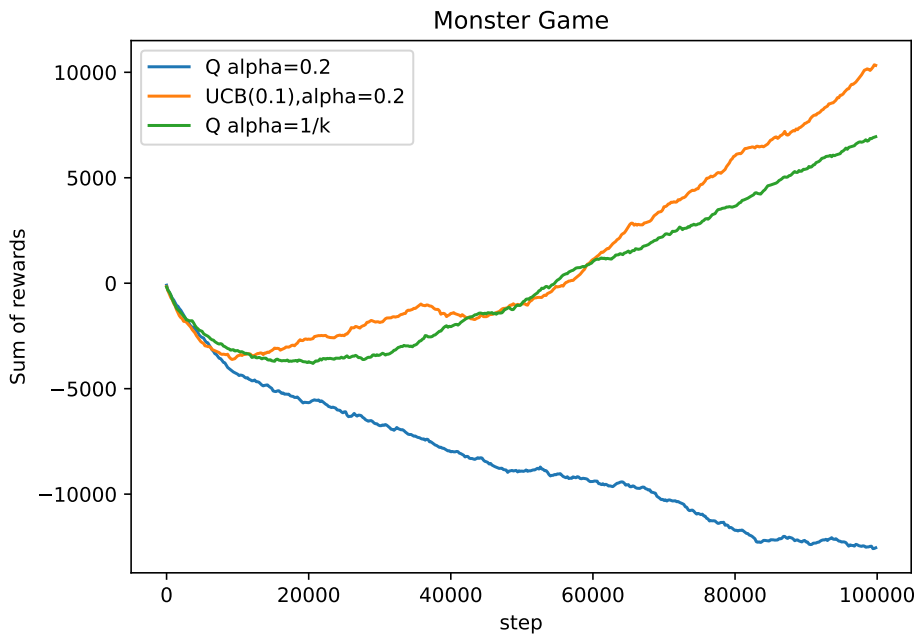

Figure 13.1: Plotting the performance of some algorithms for the monster game

```

88     self.action = self.agent.select_action(reward,state)
89     self.display(2,f"    action={self.action}")
90     return self

```

The following plots the sum of rewards as a function of the step in a simulation. Figure 13.1 shows the performance of three algorithms for the Monster Game (Sections 12.2.1 and 13.1.6). On the x-axis is the number of actions. On the y-axis is the cumulative reward. The algorithm corresponding to the blue line has not learned very well; the plot keeps going down (but less than it did initially). The learner represented by the green line starts getting positive performance after about 20,000 steps. It took about 55,000 steps for it to have gained back the cost of exploration (when it crosses $y = 0$). The learner represented by the orange line seems to have learned quicker, but is more erratic. Each algorithm should be run multiple times, because the performance can vary a lot, even for the same problem, algorithm, and parameter settings. This graph can be reproduced (but the lines will be different) using code at the bottom of `RLQlearner.py`.

```

rLProblem.py — (continued)
91     def plot(self, label=None, step_size=None, xscale='linear'):
92         """
93         plots the rewards history in the simulation
94         label is the label for the plot
95         step_size is the number of steps between each point plotted

```

```

96     xscale is 'log' or 'linear'
97
98     returns sum of rewards
99     """
100    if step_size is None: #for long simulations (> 999), only plot some
        points
101        step_size = max(1,len(self.reward_history)//500)
102    if label is None:
103        label = self.agent.name
104    plt.ion()
105    fig, ax = plt.subplots()
106    ax.set_xscale(xscale)
107    ax.set_title(self.env.name)
108    ax.set_xlabel("step")
109    ax.set_ylabel("Sum of rewards")
110    sum_history, sum_rewards = acc_rews(self.reward_history, step_size)
111    ax.plot(range(0,len(self.reward_history),step_size), sum_history,
        label=label)
112    ax.legend()
113    plt.draw()
114    return sum_rewards
115
116 def acc_rews(rews,step_size):
117     """returns the rolling sum of the values, sampled each step_size, and
        the sum
118     """
119     acc = []
120     sumr = 0; i=0
121     for e in rews:
122         sumr += e
123         i += 1
124         if (i%step_size == 0): acc.append(sumr)
125     return acc, sumr

```

13.1.4 Party Environment

Here is the definition of the simple 2-state, 2-action decision about whether to party or relax (Example 12.29 in Poole and Mackworth [2023]). (Compare to the MDP representation of page 324)

```

_____rlExamples.py — Some example reinforcement learning environments_____
11 from rlProblem import RL_env
12 class Party_env(RL_env):
13     def __init__(self):
14         RL_env.__init__(self, "Party Decision", ["party", "relax"],
            "healthy")
15
16     def do(self, action):
17         """updates the state based on the agent doing action.
18         returns reward,state

```

```

19     """
20     if self.state=="healthy":
21         if action=="party":
22             self.state = "healthy" if flip(0.7) else "sick"
23             self.reward = 10
24         else: # action=="relax"
25             self.state = "healthy" if flip(0.95) else "sick"
26             self.reward = 7
27     else: # self.state=="sick"
28         if action=="party":
29             self.state = "healthy" if flip(0.1) else "sick"
30             self.reward = 2
31         else:
32             self.state = "healthy" if flip(0.5) else "sick"
33             self.reward = 0
34     return self.reward, self.state

```

13.1.5 Environment from a Problem Domain

`Env_fom_ProblemDomain` takes a `ProblemDomain` (page 325) and constructs an environment that can be used for reinforcement learners.

As explained in Section 12.2.1, the representation of an MDP does not contain enough information to simulate a system, because it loses any dependency between the rewards and the resulting state (e.g., hitting the wall and having a negative reward may be correlated), and only represents the expected value of rewards, not how they are distributed. The `ProblemDomain` class defines the `result` method to map states and actions into distributions over (reward, state) pairs.

rlProblem.py — (continued)

```

127
128 class Env_from_ProblemDomain(RL_env):
129     def __init__(self, prob_dom):
130         RL_env.__init__(self, prob_dom.title, prob_dom.actions,
131                        prob_dom.state)
132         self.problem_domain = prob_dom
133         self.state = prob_dom.state
134         self.x_dim = prob_dom.x_dim
135         self.y_dim = prob_dom.y_dim
136         self.offsets = prob_dom.offsets
137         self.state2pos = self.problem_domain.state2pos
138         self.state2goal = self.problem_domain.state2goal
139         self.pos2state = self.problem_domain.pos2state
140
141     def do(self, action):
142         """updates the state based on the agent doing action.
143         returns state,reward
144         """

```

4	P ₁	R			P ₂
3			M		
2					M
1	M	M		M	
0	P ₃				P ₄
	0	1	2	3	4

Figure 13.2: Monster game

```

144     (self.reward, self.state) =
        select_from_dist(self.problem_domain.result(self.state, action))
145     self.problem_domain.state = self.state
146     self.display(2, f"do({action} -> ({self.reward}, {self.state}))")
147     return (self.reward, self.state)

```

13.1.6 Monster Game Environment

This is for the game depicted in Figure 13.2 (Example 13.2 of Poole and Mackworth [2023]). This is an alternative representation to that of Section 12.2.1, which defined the distribution over reward-state pairs. This directly builds a simulator, which might be easier to understand and easier adapt to new environments.

There are $25 * 5 * 2 = 250$ states. The agent does not know anything about how the environment works; it just knows what actions are available to it and what state it is in. It has to learn what to do.

```

-----rlExamples.py --- (continued) -----
36 import random
37 from utilities import flip
38 from rlProblem import RL_env
39
40 class Monster_game_env(RL_env):
41     x_dim = 5
42     y_dim = 5
43
44     vwalls = [(0,3), (0,4), (1,4)] # vertical walls right of these locations
45     hwalls = [] # not implemented
46     crashed_reward = -1

```

```

47 prize_locs = [(0,0), (0,4), (4,0), (4,4)]
48 prize_appears_prob = 0.3
49 prize_reward = 10
50
51
52 monster_locs = [(0,1), (1,1), (2,3), (3,1), (4,2)]
53 monster_appears_prob = 0.4
54 monster_reward_when_damaged = -10
55 repair_stations = [(1,4)]
56
57 actions = ["up", "down", "left", "right"]
58
59 def __init__(self):
60     # State:
61     self.x = 2
62     self.y = 2
63     self.damaged = False
64     self.prize = None
65     # Statistics
66     self.number_steps = 0
67     self.accumulated_rewards = 0 # sum of rewards received
68     self.min_accumulated_rewards = 0
69     self.min_step = 0
70     self.zero_crossing = 0
71     RL_env.__init__(self, "Monster Game", self.actions, (self.x,
72                 self.y, self.damaged, self.prize))
73     self.display(2, "", "Step", "Tot Rew", "Ave Rew", sep="\t")
74
75 def do(self, action):
76     """updates the state based on the agent doing action.
77     returns reward, state
78     """
79     assert action in self.actions, f"Monster game, unknown action:
80         {action}"
81     self.reward = 0.0
82     # A prize can appear:
83     if self.prize is None and flip(self.prize_appears_prob):
84         self.prize = random.choice(self.prize_locs)
85     # Actions can be noisy
86     if flip(0.4):
87         actual_direction = random.choice(self.actions)
88     else:
89         actual_direction = action
90     # Modeling the actions given the actual direction
91     if actual_direction == "right":
92         if self.x==self.x_dim-1 or (self.x,self.y) in self.vwalls:
93             self.reward += self.crashed_reward
94         else:
95             self.x += 1
96     elif actual_direction == "left":

```

```

95         if self.x==0 or (self.x-1,self.y) in self.vwalls:
96             self.reward += self.crashed_reward
97         else:
98             self.x += -1
99     elif actual_direction == "up":
100         if self.y==self.y_dim-1:
101             self.reward += self.crashed_reward
102         else:
103             self.y += 1
104     elif actual_direction == "down":
105         if self.y==0:
106             self.reward += self.crashed_reward
107         else:
108             self.y += -1
109     else:
110         raise RuntimeError(f"unknown_direction: {actual_direction}")
111
112     # Monsters
113     if (self.x,self.y) in self.monster_locs and
114         flip(self.monster_appears_prob):
115         if self.damaged:
116             self.reward += self.monster_reward_when_damaged
117         else:
118             self.damaged = True
119     if (self.x,self.y) in self.repair_stations:
120         self.damaged = False
121
122     # Prizes
123     if (self.x,self.y) == self.prize:
124         self.reward += self.prize_reward
125         self.prize = None
126
127     # Statistics
128     self.number_steps += 1
129     self.accumulated_rewards += self.reward
130     if self.accumulated_rewards < self.min_accumulated_rewards:
131         self.min_accumulated_rewards = self.accumulated_rewards
132         self.min_step = self.number_steps
133     if self.accumulated_rewards>0 and
134         self.reward>self.accumulated_rewards:
135         self.zero_crossing = self.number_steps
136     self.display(2,"",self.number_steps,self.accumulated_rewards,
137                 self.accumulated_rewards/self.number_steps,sep="\t")

```

The following methods are used by the GUI (Section 13.7, page 371) so that the states can be shown.

rlExamples.py — (continued)

```

139     ### For GUI

```

```

140     def state2pos(self, state):
141         """the (x,y) position for the state
142         """
143         (x, y, damaged, prize) = state
144         return (x,y)
145
146     def state2goal(self, state):
147         """the (x,y) position for the goal
148         """
149         (x, y, damaged, prize) = state
150         return prize
151
152     def pos2state(self, pos):
153         """the state corresponding to the (x,y) position.
154         The damages and prize are not shown in the GUI
155         """
156         (x,y) = pos
157         return (x, y, self.damaged, self.prize)

```

13.2 Q Learning

To run the Q-learning demo, in folder "aipython", load "rlQLearner.py", and copy and paste the example queries at the bottom of that file.

```

rQLearner.py — Q Learning
11 import random
12 import math
13 from display import Displayable
14 from utilities import argmaxe, argmaxd, flip
15 from rlProblem import RL_agent, epsilon_greedy, ucb
16
17 class Q_learner(RL_agent):
18     """A Q-learning agent has
19     belief-state consisting of
20     state is the previous state (initialized by RL_agent
21     q is a {(state,action):value} dict
22     visits is a {(state,action):n} dict. n is how many times action was
23     done in state
24     acc_rewards is the accumulated reward
25     """
26
27 rQLearner.py — (continued)
26     def __init__(self, name, actions, discount,
27                 exploration_strategy=epsilon_greedy, es_kwargs={},
28                 alpha_fun=lambda _:0.2, Qinit=0):
29         """

```

```

30     name is string representation of the agent
31     actions is the set of actions the agent can do
32     discount is the discount factor
33     exploration_strategy is the exploration function, default
34         "epsilon_greedy"
35     es_kwargs is extra arguments of exploration_strategy
36     alpha_fun is a function that computes alpha from the number of
37         visits
38     Qinit is the initial q-value
39     """
40     RL_agent.__init__(self, actions)
41     self.name = name
42     self.discount = discount
43     self.exploration_strategy = exploration_strategy
44     self.es_kwargs = es_kwargs
45     self.alpha_fun = alpha_fun
46     self.Qinit = Qinit
47     self.acc_rewards = 0
48     self.Q = {}
49     self.visits = {}

```

The initial action is a random action. It remembers the state, and initializes the data structures.

```

rlQLearner.py — (continued)
49     def initial_action(self, state):
50         """ Returns the initial action; selected at random
51         Initialize Data Structures
52         """
53         self.state = state
54         self.Q[state] = {act:self.Qinit for act in self.actions}
55         self.visits[state] = {act:0 for act in self.actions}
56         self.action = self.exploration_strategy(state, self.Q[state],
57             self.visits[state],**self.es_kwargs)
58         self.display(2, f"Initial State: {state} Action {self.action}")
59         self.display(2, "s\ta\tr\ts\tQ")
60         # display looks best if states and actions are < 8 characters
61         return self.action
62
63     def select_action(self, reward, next_state):
64         """give reward and next state, select next action to be carried
65         out"""
66         if next_state not in self.visits: # next_state not seen before
67             self.Q[next_state] = {act:self.Qinit for act in self.actions}
68             self.visits[next_state] = {act:0 for act in self.actions}
69         self.visits[self.state][self.action] +=1
70         alpha = self.alpha_fun(self.visits[self.state][self.action])
71         self.Q[self.state][self.action] += alpha*(
72             reward
73             + self.discount * max(self.Q[next_state].values())
74             - self.Q[self.state][self.action])

```

```

74     self.display(2,self.state, self.action, reward, next_state,
75                  self.Q[self.state][self.action], sep='\t')
76     self.action = self.exploration_strategy(next_state,
77                  self.Q[next_state],
78                  self.visits[next_state]**self.es_kwargs)
79     self.state = next_state
80     self.display(3,f"Agent {self.name} doing {self.action} in state
      {self.state}")
      return self.action

```

The GUI requires the $q(s, a)$ functions:

```

_____rlQLearner.py — (continued)_____
82     def q(self,s,a):
83         if s in self.Q and a in self.Q[s]:
84             return self.Q[s][a]
85         else:
86             return self.Qinit

```

SARSA is the same as Q-learning except in the action selection. SARSA changes 3 lines:

```

_____rlQLearner.py — (continued)_____
88     class SARSA(Q_learner):
89         def __init__(self,*args, **kwargs):
90             Q_learner.__init__(self,*args, **kwargs)
91
92         def select_action(self, reward, next_state):
93             """give reward and next state, select next action to be carried
94                out"""
95             if next_state not in self.visits: # next state not seen before
96                 self.Q[next_state] = {act:self.Qinit for act in self.actions}
97                 self.visits[next_state] = {act:0 for act in self.actions}
98             self.visits[self.state][self.action] +=1
99             alpha = self.alpha_fun(self.visits[self.state][self.action])
100            next_action = self.exploration_strategy(next_state,
101                self.Q[next_state],
102                self.visits[next_state]**self.es_kwargs)
103            self.Q[self.state][self.action] += alpha*(
104                reward
105                + self.discount * self.Q[next_state][next_action]
106                - self.Q[self.state][self.action])
107            self.display(2,self.state, self.action, reward, next_state,
108                self.Q[self.state][self.action], sep='\t')
109            self.state = next_state
110            self.action = next_action
111            self.display(3,f"Agent {self.name} doing {self.action} in state
      {self.state}")
      return self.action

```

13.2.1 Exploration Strategies

Two explorations strategies are defined: epsilon-greedy and upper confidence bound (UCB).

In general an exploration strategy takes two arguments, and some optional arguments depending on the strategy.

- *State* is the state that action is chosen for
- *Qs* is a $\{action : q_value\}$ dictionary for the state
- *visits* is a $\{action : n\}$ dictionary for the current state; where n is the number of times that the action has been carried out in the current state.

```

r1Problem.py — (continued)
149 def epsilon_greedy(state, Qs, visits={}, epsilon=0.2):
150     """select action given epsilon greedy
151     Qs is the {action:Q-value} dictionary for current state
152     visits is ignored
153     epsilon is the probability of acting randomly
154     """
155     if flip(epsilon):
156         return random.choice(list(Qs.keys())) # act randomly
157     else:
158         return argmaxd(Qs) # pick an action with max Q
159
160 def ucb(state, Qs, visits, c=1.4):
161     """select action given upper-confidence bound
162     Qs is the {action:Q-value} dictionary for current state
163     visits is the {action:n} dictionary for current state
164
165     0.01 is to prevent divide-by zero when visits[a]==0
166     """
167     Ns = sum(visits.values())
168     ucb1 = {a:Qs[a]+c*math.sqrt(Ns/(0.01+visits[a]))
169             for a in Qs.keys()}
170     action = argmaxd(ucb1)
171     return action

```

Exercise 13.1 Implement a soft-max action selection. Choose a temperature that works well for the domain. Explain how you picked this temperature. Compare the epsilon-greedy, ucb, soft-max and optimism in the face of uncertainty for various parameter settings.

13.2.2 Testing Q-learning

The unit tests are for the 2-action 2-state decision about whether to relax or party (Example 12.29 of Poole and Mackworth [2023]).

Note that simulating the same agent multiple times does not restart the agent; it keeps learning. Try the plotting some of the other methods; make sure to try multiple agents with the same parameter values before deciding whether a method with particular parameter settings is good or not. To do this, make sure you construct a new agent.

```

rQLearner.py -- (continued)
112 ##### TEST CASES #####
113 from rlProblem import Simulate,epsilon_greedy, ucb, Env_from_ProblemDomain
114 from rlExamples import Party_env, Monster_game_env
115 from rlQLearner import Q_learner
116 from mdpExamples import MDptiny, partyMDP
117
118 def test_RL(learnerClass, mdp=partyMDP, env=Party_env(), discount=0.9,
119            eps=5, rl_steps=100000, **kwargs):
120     """tests whether RL on env has the same (within eps) Q-values as vi on
121        mdp.
122        eps=5 is reasonable for partyMDP (with 100000 steps) but may not be for
123        other environments """
124     mdp1 = mdp(discount=discount)
125     q1,v1,pi1 = mdp1.vi(1000)
126     ag = learnerClass(learnerClass.__name__, env.actions, discount,
127                      **kwargs)
128     sim = Simulate(ag,env).start()
129     sim.go(rl_steps)
130     same = all(abs(ag.q(s,a)-q1[s][a]) < eps
131               for s in mdp1.states
132               for a in mdp1.actions)
133     assert same, (f"Unit test failed for {env.name}, in {ag.name} Q="
134                 +str({(s,a):ag.q(s,a) for s in mdp1.states
135                       for a in mdp1.actions})
136                 +f" in vi Q={q1}")
137     print(f"Unit test passed. For {env.name}, {ag.name} has same Q-value as
138           value iteration")
139 if __name__ == "__main__":
140     test_RL(Q_learner, alpha_fun=lambda k:10/(9+k))
141     #test_RL(SARSA) # should this pass? Why or why not?

```

The following are some calls you can play with. Run the commented-out code. Try other agents, including agents with the same settings.

```

rQLearner.py -- (continued)
138 #env = Party_env()
139 env = Env_from_ProblemDomain(MDptiny())
140 # Some RL agents with different parameters:
141 ag = Q_learner("eps (0.1) greedy", env.actions, 0.7)
142 ag_ucb = Q_learner("ucb", env.actions, 0.7, exploration_strategy = ucb,
143                  es_kwargs={'c':0.1})
144 ag_opt = Q_learner("optimistic", env.actions, 0.7, Qinit=100,
145                  es_kwargs={'epsilon':0})

```

```

144 ag_exp_m = Q_learner("more explore", env.actions, 0.7,
    es_kwargs={'epsilon':0.5})
145 ag_greedy = Q_learner("disc 0.1", env.actions, 0.1, Qinit=100)
146 sa = SARSA("SARSA", env.actions, 0.9)
147 suchb = SARSA("SARSA ucb", env.actions, 0.9, exploration_strategy = ucb,
    es_kwargs={'c':1})
148
149 sim_ag = Simulate(ag,env).start()
150
151 # sim_ag.go(1000)
152 # ag.Q # get the learned Q-values
153 # sim_ag.plot()
154 # sim_ucb = Simulate(ag_ucb,env).start(); sim_ucb.go(1000); sim_ucb.plot()
155 # Simulate(ag_opt,env).start().go(1000).plot()
156 # Simulate(ag_exp_m,env).start().go(1000).plot()
157 # Simulate(ag_greedy,env).start().go(1000).plot()
158 # Simulate(sa,env).start().go(1000).plot()
159 # Simulate(suchb,env).start().go(1000).plot()
160
161 from mdpExamples import MDPTiny
162 envt = Env_from_ProblemDomain(MDPTiny())
163 agt = Q_learner("Q alpha=0.8", envt.actions, 0.8)
164 #Simulate(agt, envt).start().go(1000).plot()
165
166 ##### Monster Game #####
167 mon_env = Monster_game_env()
168 mag1 = Q_learner("Q alpha=0.2", mon_env.actions, 0.9)
169 #Simulate(mag1,mon_env).start().go(100000).plot()
170 mag_ucb = Q_learner("UCB(0.1),alpha=0.2", mon_env.actions, 0.9,
    exploration_strategy = ucb, es_kwargs={'c':0.1})
171 #Simulate(mag_ucb,mon_env).start().go(100000).plot()
172
173
174 mag2 = Q_learner("Q alpha=1/k", mon_env.actions, 0.9,
    alpha_fun=lambda k:1/k)
175 #Simulate(mag2,mon_env).start().go(100000).plot()
176 mag3 = Q_learner("alpha=10/(9+k)", mon_env.actions, 0.9,
    alpha_fun=lambda k:10/(9+k))
177 #Simulate(mag3,mon_env).start().go(100000).plot()
178
179
180
181 mag4 = Q_learner("ucb & alpha=10/(9+k)", mon_env.actions, 0.9,
    alpha_fun=lambda k:10/(9+k),
    exploration_strategy = ucb, es_kwargs={'c':0.1})
182 #Simulate(mag4,mon_env).start().go(100000).plot()
183
184

```

13.3 Q-learning with Experience Replay

A bounded buffer remembers values up to size `buffer_size`. Random values can be obtained using `get`. Once the bounded buffer is full, all old experiences have the same chance of being in the buffer.

```

rIQExperienceReplay.py — Q-Learner with Experience Replay
11 from rlQLearner import Q_learner
12 from utilities import flip
13 import random
14
15 class BoundedBuffer(object):
16     def __init__(self, buffer_size=1000):
17         self.buffer_size = buffer_size
18         self.buffer = [0]*buffer_size
19         self.number_added = 0
20
21     def add(self, new_value):
22         if self.number_added < self.buffer_size:
23             self.buffer[self.number_added] = new_value
24         else:
25             if flip(self.buffer_size/self.number_added):
26                 position = random.randrange(self.buffer_size)
27                 self.buffer[position] = new_value
28             self.number_added += 1
29
30     def get(self):
31         return self.buffer[random.randrange(min(self.number_added,
32                                                 self.buffer_size))]

```

A Q_ER_Learner does Q-learning with experience replay. It only uses action replay after burn_in number of steps.

```

rIQExperienceReplay.py — (continued)
33 class Q_ER_learner(Q_learner):
34     def __init__(self, name, actions, discount,
35                 max_buffer_size=10000,
36                 num_updates_per_action=10, burn_in=100, **q_kwargs):
37         """Q-learner with experience replay
38         name is the name of the agent (e.g., in a game)
39         actions is the set of actions the agent can do
40         discount is the discount factor
41         max_buffer_size is the maximum number of past experiences that is
42             remembered
43         burn_in is the number of steps before using old experiences
44         num_updates_per_action is the number of q-updates for past
45             experiences per action
46         q_kwargs are any extra parameters for Q_learner
47         """
48         Q_learner.__init__(self, name, actions, discount, **q_kwargs)
49         self.experience_buffer = BoundedBuffer(max_buffer_size)
50         self.num_updates_per_action = num_updates_per_action
51         self.burn_in = burn_in
52
53     def select_action(self, reward, next_state):
54         """give reward and new state, select next action to be carried
55             out"""

```

```

53     self.experience_buffer.add((self.state,self.action,reward,next_state))
54         #remember experience
55     if next_state not in self.visits: # next_state not seen before
56         self.Q[next_state] = {act:self.Qinit for act in self.actions}
57         self.visits[next_state] = {act:0 for act in self.actions}
58     self.visits[self.state][self.action] +=1
59     alpha = self.alpha_fun(self.visits[self.state][self.action])
60     self.Q[self.state][self.action] += alpha*(
61         reward
62         + self.discount * max(self.Q[next_state].values())
63         - self.Q[self.state][self.action])
64     self.display(2,self.state, self.action, reward, next_state,
65                 self.Q[self.state][self.action], sep='\t')
66     # do some updates from experience buffer
67     if self.experience_buffer.number_added > self.burn_in:
68         for i in range(self.num_updates_per_action):
69             (s,a,r,ns) = self.experience_buffer.get()
70             self.visits[s][a] +=1 # is this correct?
71             alpha = self.alpha_fun(self.visits[s][a])
72             self.Q[s][a] += alpha * (r +
73                 self.discount* max(self.Q[ns][na]
74                 for na in self.actions)
75                 -self.Q[s][a] )
76     ### CHOOSE NEXT ACTION ###
77     self.action = self.exploration_strategy(next_state,
78                 self.Q[next_state],
79                 self.visits[next_state]**self.es_kwargs)
80     self.state = next_state
81     self.display(3,f"Agent {self.name} doing {self.action} in state
82                 {self.state}")
83     return self.action

```

The following code plots the performance. The experience replay learner performance cannot be directly compared to Q-learning as it does more updates per action.

```

_____rlQExperienceReplay.py — (continued) _____
82 from rlProblem import Simulate
83 from rlExamples import Monster_game_env
84 from rlQLearner import mag1, mag2, mag3
85
86 mon_env = Monster_game_env()
87 mag1ar = Q_ER_learner("Q_ER", mon_env.actions,0.9,
88                       num_updates_per_action=5, burn_in=100)
89 # Simulate(mag1ar,mon_env).start().go(100000).plot()
90
91 mag3ar = Q_ER_learner("Q_ER alpha=10/(9+k)", mon_env.actions, 0.9,
92                       num_updates_per_action=50, burn_in=1000,
93                       alpha_fun=lambda k:10/(9+k))
94 # Simulate(mag3ar,mon_env).start().go(100000).plot()
95

```

```

96 | from rlQLearner import test_RL
97 | if __name__ == "__main__":
98 |     test_RL(Q_ER_learner, alpha_fun=lambda k:10/(9+k))

```

Exercise 13.2 Why does this have a burn-in? What problem might this solve? How much does the burn-in affect the result?

Exercise 13.3 What is a fair way to compare the learning rate of `Q_ER_learner` and `Q_learner`, or `Q_ER_learners` with different values of `num_updates_per_action`? (Would this matter if the environment is a simulation versus in the real world?) Implement a comparison that counts the number of updates, rather than the number of actions. How much does `num_updates_per_action` matter?

13.4 Stochastic Policy Learning Agent

The following agent is like a Q-learning agent but maintains a stochastic policy. The policy is represented as unnormalized counts for each action in a state (as in a Dirichlet distribution). This is the code described in Section 14.7.2 and Figure 14.10 of Poole and Mackworth [2023].

```

_____rlStochasticPolicy.py — Simulations of agents learning_____
11 | from display import Displayable
12 | import utilities # argmaxall for (element,value) pairs
13 | import matplotlib.pyplot as plt
14 | import random
15 | from rlQLearner import Q_learner
16 |
17 | class StochasticPIAgent(Q_learner):
18 |     """This agent maintains the Q-function for each state.
19 |     Chooses the best action using empirical distribution over actions
20 |     """
21 |     def __init__(self, name, actions, discount=0, pi_init=1, **nargs):
22 |         """
23 |         name is the name of the agent (e.g., in a game)
24 |         actions is the set of actions the agent can do.
25 |         discount is the discount factor (0 is appropriate if there is a
26 |         single state)
27 |         pi_init gives the prior counts (Dirichlet prior) for the policy
28 |         (must be >0)
29 |         """
30 |         #self.max_display_level = 3
31 |         Q_learner.__init__(self, name, actions, discount,
32 |                             exploration_strategy=self.action_from_stochastic_policy,
33 |                             **nargs)
34 |         self.pi_init = pi_init
35 |         self.pi = {}
36 |
37 |     def initial_action(self, state):
38 |         """ update policy pi then do initial action from Q_learner

```

```

37     """
38     self.pi[state] = {act:self.pi_init for act in self.actions}
39     return Q_learner.initial_action(self, state)
40
41     def action_from_stochastic_policy(self, next_state, qs, vs):
42         a_best = utilities.argmaxd(self.Q[self.state])
43         self.pi[self.state][a_best] +=1
44         if next_state not in self.pi:
45             self.pi[next_state] = {act:self.pi_init for act in
46                                     self.actions}
47             return select_from_dist(self.pi[next_state])
48
49     def normalize(dist):
50         """dict is a {value:number} dictionary, where the numbers are all
51         non-negative
52         returns dict where the numbers sum to one
53         """
54         tot = sum(dist.values())
55         return {var:val/tot for (var,val) in dist.items()}
56
57     def select_from_dist(dist):
58         rand = random.random()
59         for (act,prob) in normalize(dist).items():
60             rand -= prob
61             if rand < 0:
62                 return act

```

The agent can be tested on the reinforcement learning benchmarks:

```

rStochasticPolicy.py — (continued)
62 ##### Testing on RL benchmarks #####
63 from rlProblem import Simulate
64 import rlExamples
65 mon_env = rlExamples.Monster_game_env()
66 magspi =StochasticPIAgent(mon_env.name, mon_env.actions,0.9)
67 #Simulate(magspi,mon_env).start().go(100000).plot()
68 magspi10 = StochasticPIAgent("stoch 10/(9+k)", mon_env.actions,0.9,
69     alpha_fun=lambd k:10/(9+k))
70 #Simulate(magspi10,mon_env).start().go(100000).plot()
71
72 from rlQLearner import test_RL
73 if __name__ == "__main__":
74     test_RL(StochasticPIAgent, alpha_fun=lambd k:10/(9+k))

```

Exercise 13.4 Test some other ways to determine the probabilities for the stochastic policy in `StochasticPIAgent`. (It currently can be seen as using a Dirichlet where the probability represents the proportion of times each action is best plus pseudo-counts).

Replace `self.pi[self.state][a_best] +=1` with something like `self.pi[self.state][a_best] *= c` for some $c > 1$. E.g., $c = 1.1$ so it chooses that action 10% more, independently of the number of times tried. (Try to change the

code as little as possible; make it so that either the original or different values of c can be run without changing your code. Warning: watch out for overflow.)

- (a) Try for multiple c ; which one works best for the Monster game?
- (b) Suggest an alternative way to update the probabilities in the policy (e.g., adding δ to policy that is then normalized or some other methods). How well does it work?

13.5 Model-based Reinforcement Learner

To run the demo, in folder “aipython”, load “rlModelLearner.py”, and copy and paste the example queries at the bottom of that file. This assumes Python 3.

A model-based reinforcement learner builds a Markov decision process model of the domain, simultaneously learns the model and plans with that model.

The model-based reinforcement learner uses the following data structures:

- $Q[s][a]$ is dictionary that, given state s and action a returns the Q -value, the estimate of the future (discounted) value of being in state s and doing action a . (Note that Q is the list but q is the function.)
- $R[s][a]$ is dictionary that, given a (s, a) state s and action a is the average reward received from doing a in state s .
- $T[s][a][s']$ is dictionary that, given states s and s' and action a returns the number of times a was done in state s and the result was state s' . Note that s' is only a key if it has been the result of doing a in s ; there are no zero counts recorded.
- $visits[s][a]$ is dictionary that, given state s and action a returns the number of times action a was carried out in state s . This is the C of Figure 13.6 of Poole and Mackworth [2023].

Note that $visits[s][a] = \sum_{s'} T[s][a][s']$ but is stored separately to keep the code more readable.

The main difference to Figure 13.6 of Poole and Mackworth [2023] is the code below does a fixed number of asynchronous value iteration updates per step.

```

rlModelLearner.py — Model-based Reinforcement Learner
11 import random
12 from rlProblem import RL_agent, Simulate, epsilon_greedy, ucb
13 from display import Displayable
14 from utilities import argmaxe, flip
15
16 class Model_based_reinforcement_learner(RL_agent):
17     """A Model-based reinforcement learner

```



```

65         self.R[next_state] = {a:0 for a in self.actions}
66     if next_state in self.T[self.state][self.action]:
67         self.T[self.state][self.action][next_state] += 1
68     else:
69         self.T[self.state][self.action][next_state] = 1
70     self.visits[self.state][self.action] += 1
71     self.R[self.state][self.action] +=
72         (reward-self.R[self.state][self.action])/self.visits[self.state][self.action]
73     st,act = self.state,self.action #initial state-action pair for AVI
74     for update in range(self.updates_per_step):
75         self.Q[st][act] = self.R[st][act]+self.discount*(
76             sum(self.T[st][act][nst]/self.visits[st][act]*self.v(nst)
77                 for nst in self.T[st][act].keys()))
78         st = random.choice(self.states_list)
79         act = random.choice(self.actions)
80     self.state = next_state
81     self.action = self.exploration_strategy(next_state,
82         self.Q[next_state],
83         self.visits[next_state]**self.es_kwargs)
84     return self.action
85
86 def q(self, state, action):
87     if state in self.Q and action in self.Q[state]:
88         return self.Q[state][action]
89     else:
90         return self.Qinit

```

r1ModelLearner.py — (continued)

```

90 from rlExamples import Monster_game_env
91 mon_env = Monster_game_env()
92 mb11 = Model_based_reinforcement_learner("model-based(1)",
93     mon_env.actions, 0.9, updates_per_step=1)
94 # Simulate(mb11,mon_env).start().go(100000).plot()
95 mb110 = Model_based_reinforcement_learner("model-based(10)",
96     mon_env.actions, 0.9, updates_per_step=10)
97 # Simulate(mb110,mon_env).start().go(100000).plot()
98
99 from rlGUI import rlGUI
100 #gui = rlGUI(mon_env, mb11)
101
102 from rlQLearner import test_RL
103 if __name__ == "__main__":
104     test_RL(Model_based_reinforcement_learner)

```

Exercise 13.5 If there were only one update per step, the algorithm could be made simpler and use less space. Explain how. Does it make it more efficient? Is it worthwhile having more than one update per step for the games implemented here?

Exercise 13.6 It is possible to implement the model-based reinforcement learner by replacing Q , R , T , $visits$, res_states with a single dictionary that, given a state

and action returns a tuple corresponding to these data structures. Does this make the algorithm easier to understand? Does this make the algorithm more efficient?

Exercise 13.7 If the states and the actions were mapped into integers, the dictionaries could be implemented perhaps more efficiently as arrays. How would the code need to change? Implement this for the monster game. Is it more efficient?

Exercise 13.8 In `random_choice` in the updates of `select_action`, all state-action pairs have the same chance of being chosen. Does selecting state-action pairs proportionally to the number of times visited work better than what is implemented? Provide evidence for your answer.

13.6 Reinforcement Learning with Features

To run the demo, in folder “aipython”, load “`rlFeatures.py`”, and copy and paste the example queries at the bottom of that file. This assumes Python 3.

This section covers Q-learning with features, where the Q-function is a linear function of feature values.

13.6.1 Representing Features

A feature is a real-valued function from state and action. For an environment, you construct a function that takes a state and an action and returns a list (vector) of real numbers.

This code only does feature engineering: the feature set is redesigned for each problem. Deep RL uses deep learning to learn features, turns out to be trickier to get to work than is generally assumed.

`party_features3` and `party_features4` return lists of feature values for the party decision. `party_features4` has one extra feature.

```

_____rlGameFeature.py — Feature-based Reinforcement Learner_____
11 from rlExamples import Monster_game_env
12 from rlProblem import RL_env
13
14 def party_features3(state,action):
15     return [1, state=="sick", action=="party"]
16
17 def party_features4(state,action):
18     return [1, state=="sick", action=="party", state=="sick" and
           action=="party"]

```

Exercise 13.9 With `party_features3` what policies can be discovered? What policies cannot be represented as

The `monster_features` defines the vector of feature values for the given state and action.

```

rGameFeature.py -- (continued)
20 def monster_features(state,action):
21     """returns the list of feature values for the state-action pair
22     """
23     assert action in Monster_game_env.actions, f"Monster game, unknown
        action: {action}"
24     (x,y,d,p) = state
25     # f1: would go to a monster
26     f1 = monster_ahead(x,y,action)
27     # f2: would crash into wall
28     f2 = wall_ahead(x,y,action)
29     # f3: action is towards a prize
30     f3 = towards_prize(x,y,action,p)
31     # f4: damaged and action is toward repair station
32     f4 = towards_repair(x,y,action) if d else 0
33     # f5: damaged and towards monster
34     f5 = 1 if d and f1 else 0
35     # f6: damaged
36     f6 = 1 if d else 0
37     # f7: not damaged
38     f7 = 1-f6
39     # f8: damaged and prize ahead
40     f8 = 1 if d and f3 else 0
41     # f9: not damaged and prize ahead
42     f9 = 1 if not d and f3 else 0
43     features = [1,f1,f2,f3,f4,f5,f6,f7,f8,f9]
44     # the next 20 features are for 5 prize locations
45     # and 4 distances from outside in all directions
46     for pr in Monster_game_env.prize_locs+[None]:
47         if p==pr:
48             features += [x, 4-x, y, 4-y]
49         else:
50             features += [0, 0, 0, 0]
51     # fp04 feature for y when prize is at 0,4
52     # this knows about the wall to the right of the prize
53     if p==(0,4):
54         if x==0:
55             fp04 = y
56         elif y<3:
57             fp04 = y
58         else:
59             fp04 = 4-y
60     else:
61         fp04 = 0
62     features.append(fp04)
63     return features
64
65 def monster_ahead(x,y,action):
66     """returns 1 if the location expected to get to by doing
67     action from (x,y) can contain a monster.

```

```

68     """
69     if action == "right" and (x+1,y) in Monster_game_env.monster_locs:
70         return 1
71     elif action == "left" and (x-1,y) in Monster_game_env.monster_locs:
72         return 1
73     elif action == "up" and (x,y+1) in Monster_game_env.monster_locs:
74         return 1
75     elif action == "down" and (x,y-1) in Monster_game_env.monster_locs:
76         return 1
77     else:
78         return 0
79
80 def wall_ahead(x,y,action):
81     """returns 1 if there is a wall in the direction of action from (x,y).
82     This is complicated by the internal walls.
83     """
84     if action == "right" and (x==Monster_game_env.x_dim-1 or (x,y) in
85         Monster_game_env.vwalls):
86         return 1
87     elif action == "left" and (x==0 or (x-1,y) in Monster_game_env.vwalls):
88         return 1
89     elif action == "up" and y==Monster_game_env.y_dim-1:
90         return 1
91     elif action == "down" and y==0:
92         return 1
93     else:
94         return 0
95
96 def towards_prize(x,y,action,p):
97     """action goes in the direction of the prize from (x,y)"""
98     if p is None:
99         return 0
100    elif p==(0,4): # take into account the wall near the top-left prize
101        if action == "left" and (x>1 or x==1 and y<3):
102            return 1
103        elif action == "down" and (x>0 and y>2):
104            return 1
105        elif action == "up" and (x==0 or y<2):
106            return 1
107        else:
108            return 0
109    else:
110        px,py = p
111        if p==(4,4) and x==0:
112            if (action=="right" and y<3) or (action=="down" and y>2) or
113                (action=="up" and y<2):
114                return 1
115            else:
116                return 0
117        if (action == "up" and y<py) or (action == "down" and py<y):

```

```

116         return 1
117     elif (action == "left" and px<x) or (action == "right" and x<px):
118         return 1
119     else:
120         return 0
121
122 def towards_repair(x,y,action):
123     """returns 1 if action is towards the repair station.
124     """
125     if action == "up" and (x>0 and y<4 or x==0 and y<2):
126         return 1
127     elif action == "left" and x>1:
128         return 1
129     elif action == "right" and x==0 and y<3:
130         return 1
131     elif action == "down" and x==0 and y>2:
132         return 1
133     else:
134         return 0

```

The following uses a simpler set of features. In particular, it only considers whether the action will most likely result in a monster position or a wall, and whether the action moves towards the current prize.

```

_____rlGameFeature.py --- (continued)_____
136 def simp_features(state,action):
137     """returns a list of feature values for the state-action pair
138     """
139     assert action in Monster_game_env.actions
140     (x,y,d,p) = state
141     # f1: would go to a monster
142     f1 = monster_ahead(x,y,action)
143     # f2: would crash into wall
144     f2 = wall_ahead(x,y,action)
145     # f3: action is towards a prize
146     f3 = towards_prize(x,y,action,p)
147     return [1,f1,f2,f3]

```

13.6.2 Feature-based RL learner

This learns a linear function approximation of the Q-values. It requires the function *get_features* that given a state and an action returns a list of values for all of the features. Each environment requires this function to be provided.

```

_____rlFeatures.py --- Feature-based Reinforcement Learner _____
11 import random
12 from rlProblem import RL_agent, epsilon_greedy, ucb
13 from display import Displayable
14 from utilities import argmaxe, flip
15 import rlGameFeature

```

```

16
17 class SARSA_LFA_learner(RL_agent):
18     """A SARSA with linear function approximation (LFA) learning agent has
19     """
20     def __init__(self, name, actions, discount,
21                 get_features=rlGameFeature.party_features4,
22                 exploration_strategy=epsilon_greedy, es_kwargs={},
23                 step_size=0.01, winit=0):
24         """name is the name of the agent (e.g., in a game)
25         actions is the set of actions the agent can do
26         discount is the discount factor
27         get_features is a function get_features(state,action) -> list of
28         feature values
29         exploration_strategy is the exploration function, default
30         "epsilon_greedy"
31         es_kwargs is extra keyword arguments of the exploration_strategy
32         step_size is gradient descent step size
33         winit is the initial value of the weights
34         """
35         RL_agent.__init__(self, actions)
36         self.name = name
37         self.discount = discount
38         self.exploration_strategy = exploration_strategy
39         self.es_kwargs = es_kwargs
40         self.get_features = get_features
41         self.step_size = step_size
42         self.winit = winit

```

The initial action is a random action. It remembers the state, and initializes the data structures.

```

-----rlFeatures.py --- (continued) -----
41 def initial_action(self, state):
42     """ Returns the initial action; selected at random
43     Initialize Data Structures
44     """
45     self.action = RL_agent.initial_action(self, state)
46     self.features = self.get_features(state, self.action)
47     self.weights = [self.winit for f in self.features]
48     self.display(2, f"Initial State: {state} Action {self.action}")
49     self.display(2, "s\ta\t\r\t's'\tQ")
50     return self.action

```

do takes in the number of steps.

```

-----rlFeatures.py --- (continued) -----
52
53 def q(self, state,action):
54     """returns Q-value of the state and action for current weights
55     """
56     return dot_product(self.weights, self.get_features(state,action))
57

```

```

58 def select_action(self, reward, next_state):
59     """do num_steps of interaction with the environment"""
60     feature_values = self.get_features(self.state,self.action)
61     oldQ = self.q(self.state,self.action)
62     next_action = self.exploration_strategy(next_state,
63         {a:self.q(next_state,a)
64           for a in self.actions}, {})
65     nextQ = self.q(next_state,next_action)
66     delta = reward + self.discount * nextQ - oldQ
67     for i in range(len(self.weights)):
68         self.weights[i] += self.step_size * delta * feature_values[i]
69     self.display(2,self.state, self.action, reward, next_state,
70                 self.q(self.state,self.action), delta, sep='\t')
71     self.state = next_state
72     self.action = next_action
73     return self.action
74
75 def show_actions(self,state=None):
76     """prints the value for each action in a state.
77     This may be useful for debugging.
78     """
79     if state is None:
80         state = self.state
81     for next_act in self.actions:
82         print(next_act,dot_product(self.weights,
83             self.get_features(state,next_act)))
84
85 def dot_product(l1,l2):
86     return sum(e1*e2 for (e1,e2) in zip(l1,l2))

```

Test code:

```

rlFeatures.py — (continued)
86 from rlProblem import Simulate
87 from rlExamples import Party_env, Monster_game_env
88 import rlGameFeature
89 from rlGUI import rlGUI
90
91 party = Party_env()
92 pa3 = SARSA_LFA_learner(party.name, party.actions, 0.9,
93     rlGameFeature.party_features3)
94 # Simulate(pa3,party).start().go(300).plot()
95 pa4 = SARSA_LFA_learner(party.name, party.actions, 0.9,
96     rlGameFeature.party_features4)
97 # Simulate(pa4,party).start().go(300).plot()
98
99 mon_env = Monster_game_env()
100 fa1 = SARSA_LFA_learner("LFA", mon_env.actions, 0.9,
101     rlGameFeature.monster_features)
102 # Simulate(fa1,mon_env).start().go(100000).plot()

```

```

100 | fas1 = SARSA_LFA_learner("LFA (simp features)", mon_env.actions, 0.9,
      |   rlGameFeature.simp_features)
101 | #Simulate(fas1,mon_env).start().go(100000).plot()
102 | # rlGUI(mon_env, SARSA_LFA_learner(mon_env.name, mon_env.actions, 0.9,
      |   rlGameFeature.monster_features))
103 |
104 | from rlQLearner import test_RL
105 | if __name__ == "__main__":
106 |     test_RL(SARSA_LFA_learner, es_kwargs={'epsilon':1}) # random exploration

```

Exercise 13.10 How does the step-size affect performance? Try different step sizes (e.g., 0.1, 0.001, other sizes in-between). Explain the behavior you observe. Which step size works best for this example. Explain what evidence you are basing your prediction on.

Exercise 13.11 Does having extra features always help? Does it sometime help? Does whether it helps depend on the step size? Give evidence for your claims.

Exercise 13.12 For each of the following first predict, then plot, then explain the behavior you observed:

- (a) SARSA_LFA, Model-based learning (with 1 update per step) and Q-learning for 10,000 steps 20% exploring followed by 10,000 steps 100% exploiting
- (b) SARSA_LFA, model-based learning and Q-learning for
 - i) 100,000 steps 20% exploring followed by 100,000 steps 100% exploit
 - ii) 10,000 steps 20% exploring followed by 190,000 steps 100% exploit
- (c) Suppose your goal was to have the best accumulated reward after 200,000 steps. You are allowed to change the exploration rate at a fixed number of steps. For each of the methods, which is the best position to start exploiting more? Which method is better? What if you wanted to have the best reward after 10,000 or 1,000 steps?

Based on this evidence, explain when it is preferable to use SARSA_LFA, Model-based learner, or Q-learning.

Important: you need to run each algorithm more than once. Your explanation should include the variability as well as the typical behavior.

Exercise 13.13 In the call to `self.exploration_strategy`, what should the counts be? (The code above will fail for `ucb`, for example.) Think about the case where there are too many states. Suppose we are just learning for a neighborhood of a current state (e.g., a fixed number of steps away the from the current state); how could the algorithm be modified to make sure it has at least explored the close neighborhood of the current state?

13.7 GUI for RL

This implements an an interactive graphical user interface for reinforcement learners. It lets the uses choose the actions and visualize the value function and/or the Q-function. It works by taking over the exploration strategy; when

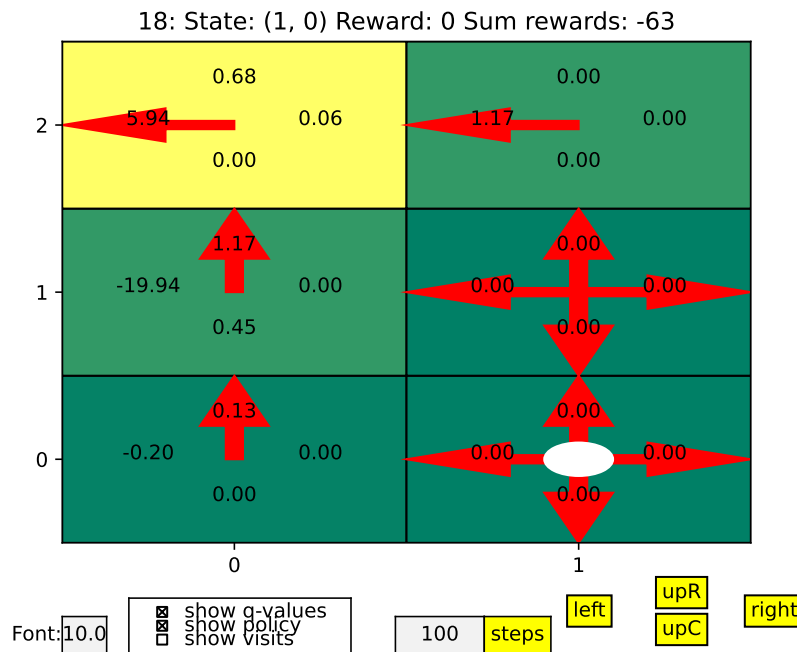

Figure 13.3: Graphical User Interface for tiny game

the agent needs to get an action, it asks the GUI. When the user requests multiple steps, it calls the original exploration strategy.

Figure 13.3 shows the GUI for the tiny game (see commented out code at the end of the file) after a 18 actions by the user. The 6 states are shown in a grid; each rectangle is a state. Within each state are 4 numbers, corresponding to the 4 actions, that give the Q-value for that state and action. The red arrows correspond to the actions with maximal Q-value for each state. The 4 yellow buttons are arranged in the same order as the Q-values. The white ellipse shows the current position of the agent. The user can simulate the agent by clicking on one of these actions. They can also click on “steps” to simulate 100 steps (in this case). The check-boxes are used to show the q-values, the policy (the red arrows) and the visits – the number of times each action has been carried out in each state (when q-values is not checked). When neither q-values or visits is checked the value for the state is shown.

Figure 13.4 shows the GUI for the monster game after 1000 steps. From the top line, you can see the agent is at location (4,2) – shown by the white dot – is damaged and the goal is at (0,4) – shown by the green dot. It is instructive to try to control the agent by clicking on the actions on the bottom right: it only does what is expected 70% of the time.

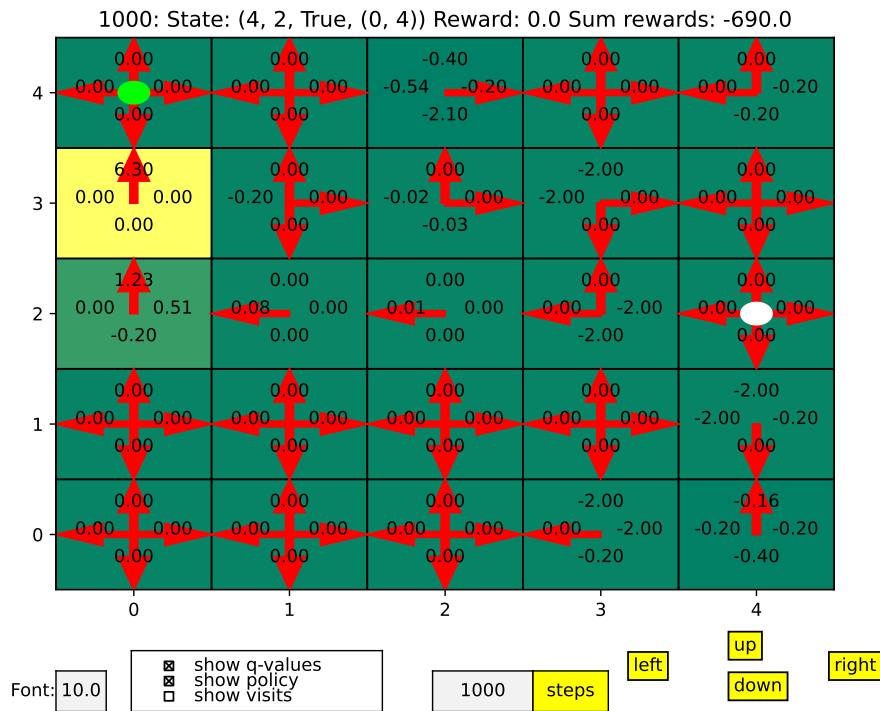

Figure 13.4: Graphical User Interface for Monster game

```

11 import matplotlib.pyplot as plt
12 from matplotlib.widgets import Button, CheckButtons, TextBox
13 from rlProblem import Simulate
14
15 class rlGUI(object):
16     def __init__(self, env, agent):
17         """
18         """
19         self.env = env
20         self.agent = agent
21         self.state = self.env.state
22         self.x_dim = env.x_dim
23         self.y_dim = env.y_dim
24         if 'offsets' in vars(env): # 'offsets' is defined in environment
25             self.offsets = env.offsets
26         else: # should be more general
27             self.offsets = {'right':(0.25,0), 'up':(0,0.25),
28                             'left':(-0.25,0), 'down':(0,-0.25)}
29         # replace the exploration strategy with GUI
30         self.orig_exp_strategy = self.agent.exploration_strategy
31         self.agent.exploration_strategy = self.actionFromGUI

```

```

31     self.do_steps = 0
32     self.quitting = False
33     self.action = None
34
35     def go(self):
36         self.q = self.agent.q
37         self.v = self.agent.v
38         try:
39             self.fig,self.ax = plt.subplots()
40             plt.subplots_adjust(bottom=0.2)
41             self.actButtons =
42                 {self.fig.text(0.8+self.offsets[a][0]*0.4,0.1+self.offsets[a][1]*0.1,a,
43                     bbox={'boxstyle':'square','color':'yellow','ec':'black'},
44                     picker=True):a #, fontsize=fontsize):a
45             for a in self.env.actions}
46             self.fig.canvas.mpl_connect('pick_event', self.sel_action)
47             self.fig.canvas.mpl_connect('close_event', self.window_closed)
48             self.sim = Simulate(self.agent, self.env)
49             self.show()
50             self.sim.start()
51             self.sim.go(1000000000000) # go forever
52         except ExitToPython:
53             print("Window closed")
54
55     def show(self):
56         self.qcheck = CheckButtons(plt.axes([0.2,0.05,0.25,0.075]),
57             ["show q-values","show policy","show
58             visits"])
59         self.qcheck.on_clicked(self.show_vals)
60         self.font_box = TextBox(plt.axes([0.125,0.05,0.05,0.05]),"Font:",
61             textalignment="center")
62         self.font_box.on_submit(self.set_font_size)
63         self.font_box.set_val(str(plt.rcParams['font.size']))
64         self.step_box = TextBox(plt.axes([0.5,0.05,0.1,0.05]),"",
65             textalignment="center")
66         self.step_box.set_val("100")
67         self.stepsButton = Button(plt.axes([0.6,0.05,0.075,0.05]), "steps",
68             color='yellow')
69         self.stepsButton.on_clicked(self.steps)
70         #self.exitButton = Button(plt.axes([0.0,0.05,0.05,0.05]), "exit",
71             color='yellow')
72         #self.exitButton.on_clicked(self.exit)
73         self.show_vals(None)
74
75     def set_font_size(self, s):
76         plt.rcParams.update({'font.size': eval(s)})
77         plt.draw()
78
79     def window_closed(self, s):
80         self.quitting = True

```

```

75
76 def show_vals(self,event):
77     self.ax.cla()
78     self.ax.set_title(f"{self.sim.step}: State: {self.state} Reward:
79     {self.env.reward} Sum rewards: {self.sim.sum_rewards}")
80     array = [[self.v(self.env.pos2state((x,y))) for x in
81             range(self.x_dim)
82             for y in range(self.y_dim)]
83     self.ax.pcolormesh([x-0.5 for x in range(self.x_dim+1)],
84                       [x-0.5 for x in range(self.y_dim+1)],
85                       array, edgecolors='black',cmap='summer')
86     # for cmap see
87     https://matplotlib.org/stable/tutorials/colors/colormaps.html
88 if self.qcheck.get_status()[1]: # "show policy"
89     for x in range(self.x_dim):
90     for y in range(self.y_dim):
91     state = self.env.pos2state((x,y))
92     maxv = max(self.agent.q(state,a) for a in
93     self.env.actions)
94     for a in self.env.actions:
95     xoff, yoff = self.offsets[a]
96     if self.agent.q(state,a) == maxv:
97     # draw arrow in appropriate direction
98     self.ax.arrow(x,y,xoff*2,yoff*2,
99     color='red',width=0.05, head_width=0.2,
100     length_includes_head=True)
101
102 if goal := self.env.state2goal(self.state):
103     self.ax.add_patch(plt.Circle(goal, 0.1, color='lime'))
104 self.ax.add_patch(plt.Circle(self.env.state2pos(self.state), 0.1,
105     color='w'))
106 if self.qcheck.get_status()[0]: # "show q-values"
107     self.show_q(event)
108 elif self.qcheck.get_status()[2] and 'visits' in vars(self.agent):
109     # "show visits"
110     self.show_visits(event)
111 else:
112     self.show_v(event)
113 self.ax.set_xticks(range(self.x_dim))
114 self.ax.set_xticklabels(range(self.x_dim))
115 self.ax.set_yticks(range(self.y_dim))
116 self.ax.set_yticklabels(range(self.y_dim))
117 plt.draw()

```

```

112 def sel_action(self,event):
113     self.action = self.actButtons[event.artist]
114
115 def show_v(self,event):
116     """show values"""
117     for x in range(self.x_dim):

```

```

118         for y in range(self.y_dim):
119             state = self.env.pos2state((x,y))
120             self.ax.text(x,y,"{val:.2f}".format(val=self.agent.v(state)),ha='center')
121
122     def show_q(self,event):
123         """show q-values"""
124         for x in range(self.x_dim):
125             for y in range(self.y_dim):
126                 state = self.env.pos2state((x,y))
127                 for a in self.env.actions:
128                     xoff, yoff = self.offsets[a]
129                     self.ax.text(x+xoff,y+yoff,
130                                 "{val:.2f}".format(val=self.agent.q(state,a)),ha='center')
131
132     def show_visits(self,event):
133         """show q-values"""
134         for x in range(self.x_dim):
135             for y in range(self.y_dim):
136                 state = self.env.pos2state((x,y))
137                 for a in self.env.actions:
138                     xoff, yoff = self.offsets[a]
139                     if state in self.agent.visits and a in
140                         self.agent.visits[state]:
141                         num_visits = self.agent.visits[state][a]
142                     else:
143                         num_visits = 0
144                     self.ax.text(x+xoff,y+yoff,
145                                 str(num_visits),ha='center')
146
147     def steps(self,event):
148         """do the steps given in step box"""
149         num_steps = int(self.step_box.text)
150         if num_steps > 0:
151             self.do_steps = num_steps-1
152             self.action = self.action_from_orig_exp_strategy()
153
154     def action_from_orig_exp_strategy(self):
155         """returns the action from the original explorations strategy"""
156         visits = self.agent.visits[self.state] if 'visits' in
157             vars(self.agent) else {}
158         return
159             self.orig_exp_strategy(self.state,{a:self.agent.q(self.state,a)
160                 for a in self.agent.actions},
161                                     visits,**self.agent.es_kwargs)
162
163     def actionFromGUI(self, state, *args, **kwargs):
164         """called as the exploration strategy by the RL agent.
165         returns an action, either from the GUI or the original exploration
166         strategy
167         """

```

```

163     self.state = state
164     if self.do_steps > 0: # use the original
165         self.do_steps -= 1
166         return self.action_from_orig_exp_strategy()
167     else: # get action from the user
168         self.show_vals(None)
169         while self.action == None and not self.quitting: #wait for user
170             action
171             plt.pause(0.05) # controls reaction time of GUI
172         if self.quitting:
173             raise ExitToPython()
174         act = self.action
175         self.action = None
176         return act
177
178 class ExitToPython(Exception):
179     """Thrown when window closes.
180     """
181     pass
182
183 from rlExamples import Monster_game_env
184 from mdpExamples import MDptiny, Monster_game
185 from rlQLearner import Q_learner, SARSA
186 from rlStochasticPolicy import StochasticPIAgent
187 from rlProblem import Env_from_ProblemDomain, epsilon_greedy, ucb
188
189 # Choose an Environment
190 env = Env_from_ProblemDomain(MDptiny())
191 # env = Env_from_ProblemDomain(Monster_game())
192 # env = Monster_game_env()
193
194 # Choose an algorithm
195 # gui = rlGUI(env, Q_learner("Q", env.actions, 0.9)); gui.go()
196 # gui = rlGUI(env, SARSA("SARSA", env.actions, 0.9)); gui.go()
197 # gui = rlGUI(env, SARSA("SARSA alpha(k)=k:10/(9+k)", env.actions, 0.9,
198 #                       alpha_fun=lambda k:10/(9+k))); gui.go()
199 # gui = rlGUI(env, SARSA("SARSA-UCB", env.actions, 0.9,
200 #                       exploration_strategy = ucb, es_kwargs={'c':0.1})); gui.go()
201 # gui = rlGUI(env, StochasticPIAgent("Q", env.actions, 0.9,
202 #                                   alpha_fun=lambda k:10/(9+k))); gui.go()
203
204 if __name__ == "__main__":
205     print("Try: rlGUI(env, Q_learner('Q', env.actions, 0.9)).go()")

```

Multiagent Systems

This chapter considers searching game trees and reinforcement learning for games.

14.1 Minimax

The following code implements search for two-player, zero-sum, perfect-information (fully-observable) games. One player only wins when another player loses. Such games can be modeled with

- a single value (utility) which one agent (the maximizing agent) is trying maximize and the other agent (the minimizing agent) is trying to minimize
- a game tree where the nodes correspond to state of the game (or the history of moves)
- each node is labelled by the player who controls the next move (the maximizing player or the minimizing player)
- the children of non-terminal node correspond to all of the actions by the agent controlling the node
- nodes at the end of the game have no children and are labeled with the value of the node (e.g., +1 for win, 0 for tie, -1 for loss).

The aim of the minimax searcher is, given a state, to find the optimal (maximizing or minimizing depending on the agent) move.

14.1.1 Creating a two-player game

```

masProblem.py — A Multiagent Problem
11 from display import Displayable
12
13 class Node(Displayable):
14     """A node in a search tree. It has a
15     name a string
16     isMax is True if it is a maximizing node, otherwise it is minimizing
17     node
18     children is the list of children
19     value is what the node evaluates to if it is a leaf.
20     """
21     def __init__(self, name, isMax, value, children):
22         self.name = name
23         self.isMax = isMax
24         self.value = value
25         self.allchildren = children
26
27     def isLeaf(self):
28         """returns true if this is a leaf node"""
29         return self.allchildren is None
30
31     def children(self):
32         """returns the list of all children."""
33         return self.allchildren
34
35     def evaluate(self):
36         """returns the evaluation for this node if it is a leaf"""
37         return self.value
38
39     def __repr__(self):
40         return self.name

```

The following gives the tree of Figure 14.1 (Figure 11.5 of Poole and Mackworth [2023]); only the leaf nodes are part of the tree; the other values are described Poole and Mackworth [2023, Section 14.3.1]. 888 is used as a value for those nodes without a value in the tree. (If you look at the trace of alpha-beta pruning, 888 never appears).

```

masProblem.py — (continued)
41 fig10_5 = Node("a", True, None, [
42     Node("b", False, None, [
43         Node("d", True, None, [
44             Node("h", False, None, [
45                 Node("h1", True, 7, None),
46                 Node("h2", True, 9, None)]],
47             Node("i", False, None, [
48                 Node("i1", True, 6, None),
49                 Node("i2", True, 888, None)]])

```

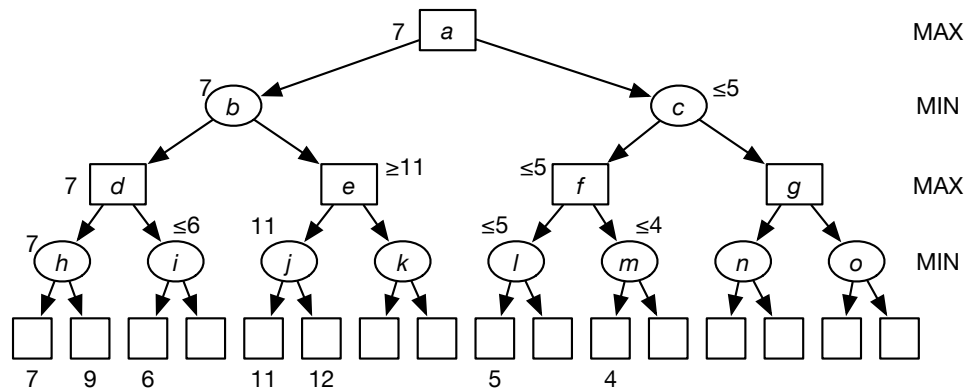

Figure 14.1: Example search tree

```

50     Node("e", True, None, [
51         Node("j", False, None, [
52             Node("j1", True, 11, None),
53             Node("j2", True, 12, None)]),
54         Node("k", False, None, [
55             Node("k1", True, 888, None),
56             Node("k2", True, 888, None)]))])),
57     Node("c", False, None, [
58         Node("f", True, None, [
59             Node("l", False, None, [
60                 Node("l1", True, 5, None),
61                 Node("l2", True, 888, None)]),
62             Node("m", False, None, [
63                 Node("m1", True, 4, None),
64                 Node("m2", True, 888, None)]))])),
65         Node("g", True, None, [
66             Node("n", False, None, [
67                 Node("n1", True, 888, None),
68                 Node("n2", True, 888, None)]),
69             Node("o", False, None, [
70                 Node("o1", True, 888, None),
71                 Node("o2", True, 888, None)]))]])

```

The following is a representation of a **magic-sum game**, where players take turns picking a number in the range $[1, 9]$, and the first player to have 3 numbers that sum to 15 wins. Note that this is a syntactic variant of **tic-tac-toe** or **naughts and crosses**. To see this, consider the numbers on a **magic square** (Figure 14.2); 3 numbers that add to 15 correspond exactly to the winning positions of tic-tac-toe played on the magic square.

masProblem.py — (continued)

```

73
74 class Magic_sum(Node):

```

6	1	8
7	5	3
2	9	4

Figure 14.2: Magic Square

```

75 def __init__(self, xmove=True, last_move=None,
76             available=[1,2,3,4,5,6,7,8,9], x=[], o=[]):
77     """This is a node in the search for the magic-sum game.
78     xmove is True if the next move belongs to X.
79     last_move is the number selected in the last move
80     available is the list of numbers that are available to be chosen
81     x is the list of numbers already chosen by x
82     o is the list of numbers already chosen by o
83     """
84     self.isMax = self.xmove = xmove
85     self.last_move = last_move
86     self.available = available
87     self.x = x
88     self.o = o
89     self.allchildren = None #computed on demand
90     lm = str(last_move)
91     self.name = "start" if not last_move else "o="+lm if xmove else
92         "x="+lm
93
94 def children(self):
95     if self.allchildren is None:
96         if self.xmove:
97             self.allchildren = [
98                 Magic_sum(xmove = not self.xmove,
99                           last_move = sel,
100                          available = [e for e in self.available if e is
101                                      not sel],
102                          x = self.x+[sel],
103                          o = self.o)
104                 for sel in self.available]
105         else:
106             self.allchildren = [
107                 Magic_sum(xmove = not self.xmove,
108                           last_move = sel,
109                          available = [e for e in self.available if e is
110                                      not sel],
111                          x = self.x,
112                          o = self.o+[sel])
113                 for sel in self.available]
114     return self.allchildren
115
116 def isLeaf(self):
117     """A leaf has no numbers available or is a win for one of the

```

```

    players.
115     We only need to check for a win for o if it is currently x's turn,
116     and only check for a win for x if it is o's turn (otherwise it would
117     have been a win earlier).
118     """
119     return (self.available == [] or
120             (sum_to_15(self.last_move,self.o)
121              if self.xmove
122              else sum_to_15(self.last_move,self.x)))
123
124     def evaluate(self):
125         if self.xmove and sum_to_15(self.last_move,self.o):
126             return -1
127         elif not self.xmove and sum_to_15(self.last_move,self.x):
128             return 1
129         else:
130             return 0
131
132     def sum_to_15(last,selected):
133         """is true if last, together with two other elements of selected sum to
134         15.
135         """
136         return any(last+a+b == 15
137                   for a in selected if a != last
138                   for b in selected if b != last and b != a)

```

14.1.2 Minimax and α - β Pruning

This is a naive depth-first **minimax algorithm** that searches the whole tree:

```

_____masMiniMax.py — Minimax search with alpha-beta pruning_____
11 def minimax(node,depth):
12     """returns the value of node, and a best path for the agents
13     """
14     if node.isLeaf():
15         return node.evaluate(),None
16     elif node.isMax:
17         max_score = float("-inf")
18         max_path = None
19         for C in node.children():
20             score,path = minimax(C,depth+1)
21             if score > max_score:
22                 max_score = score
23                 max_path = C.name,path
24         return max_score,max_path
25     else:
26         min_score = float("inf")
27         min_path = None
28         for C in node.children():
29             score,path = minimax(C,depth+1)
30             if score < min_score:

```

```

31         min_score = score
32         min_path = C.name,path
33     return min_score,min_path

```

The following is a depth-first minimax with α - β pruning. It returns the value for a node as well as a best path for the agents.

```

-----masMiniMax.py --- (continued) -----
35 def minimax_alpha_beta(node, alpha, beta, depth=0):
36     """node is a Node,
37     alpha and beta are cutoffs
38     depth is the depth on node (for indentation in printing)
39     returns value, path
40     where path is a sequence of nodes that results in the value
41     """
42     node.display(2, " "*depth, f"minimax_alpha_beta({node.name}, {alpha},
43         {beta})")
44     best=None # only used if it will be pruned
45     if node.isLeaf():
46         node.display(2, " "*depth, f"{node} leaf value {node.evaluate()}")
47         return node.evaluate(),None
48     elif node.isMax:
49         for C in node.children():
50             score,path = minimax_alpha_beta(C,alpha,beta,depth+1)
51             if score >= beta: # beta pruning
52                 node.display(2, " "*depth, f"{node} pruned {beta=}, {C=}")
53                 return score, None
54             if score > alpha:
55                 alpha = score
56                 best = C.name, path
57             node.display(2, " "*depth, f"{node} returning max {alpha=}, {best=}")
58             return alpha,best
59     else:
60         for C in node.children():
61             score,path = minimax_alpha_beta(C,alpha,beta,depth+1)
62             if score <= alpha: # alpha pruning
63                 node.display(2, " "*depth, f"{node} pruned {alpha=}, {C=}")
64                 return score, None
65             if score < beta:
66                 beta=score
67                 best = C.name,path
68             node.display(2, " "*depth, f"{node} returning min {beta=}, {best=}")
69             return beta,best

```

Testing:

```

-----masMiniMax.py --- (continued) -----
70 from masProblem import fig10_5, Magic_sum, Node
71
72 # Node.max_display_level=2 # print detailed trace
73 # minimax_alpha_beta(fig10_5, -9999, 9999,0)
74 # minimax_alpha_beta(Magic_sum(), -9999, 9999,0)

```

```

75 |
76 | #To test much time alpha-beta pruning can save over minimax:
77 | ## import timeit
78 | ## timeit.Timer("minimax(Magic_sum(),0)",setup="from __main__ import
    |     minimax, Magic_sum").timeit(number=1)
79 | ## timeit.Timer("minimax_alpha_beta(Magic_sum(), -9999, 9999,0)",
    |     setup="from __main__ import minimax_alpha_beta,
    |     Magic_sum").timeit(number=1)

```

Exercise 14.1 In the magic-sum game, a state is represented as lists of moves. The same state could be reached by more than one sequence of moves. Change the representation of the game and/or the search procedures to recognize when the value of a state has already been computed. How much does this improve the search?

Exercise 14.2 There are symmetries in tic-tac toe, such as rotation and reflection. How can the representation and/or the algorithm be changed to recognize symmetries? How much difference does it make?

14.2 Multiagent Learning

The next code is for multiple agents that learn when interacting with other agents. The main difference from the simulator of the last chapter is that the games take actions from all the agents and provide a separate reward to each agent. Any of the reinforcement learning agents from the last chapter can be used.

14.2.1 Simulating Multiagent Interaction with an Environment

A game has a name, a list of player roles (which are strings for printing), a list of lists of actions (`actions[i][j]` is the j th action for agent i), a list of states, and an initial state. The default is to have a single state, and the initial state is a randomly selected state.

```

_____masLearn.py — Multiagent learning_____
11 | import random
12 | from display import Displayable
13 | import matplotlib.pyplot as plt
14 | from rlProblem import RL_agent
15 |
16 | class Game(Displayable):
17 |     def __init__(self, name, players, actions, states=['s0'],
    |         initial_state=None):
18 |         self.name = name
19 |         self.players = players # list of roles (strings) of the players
20 |         self.num_players = len(players)
21 |         self.actions = actions # action[i] is list of actions for agent i

```

```

22     self.states = states # list of environment states; default single
        state
23     if initial_state is None:
24         self.initial_state = random.choice(states)
25     else:
26         self.initial_state = initial_state

```

The simulation for a game passes the joint action from all the agents to the environment, which returns a tuple of rewards – one for each agent – and the next state.

```

masLearn.py — (continued)
28     def sim(self, ag_types, discount=0):
29         """returns a simulation using default values for agent types
30             (This is a simple interface to SimulateGame)
31             ag_types is a list of agent functions (one for each player in the
                game)
32             The default is for one-off games where discount=0
33         """
34         return SimulateGame(self,
35                             [ag_types[i](ag_types[i].__name__,
36                                         self.actions[i], discount)
37                             for i in range(self.num_players)])
38     class SimulateGame(Displayable):
39         """A simulation of a game.
40             (This is not subclass of a game, as a game can have multiple games.)
41         """
42         def __init__(self, game, agents):
43             """ Simulates game
44                 agents is a list of agents, one for each player in the game
45             """
46             #self.max_display_level = 3
47             self.game = game
48             self.agents = agents
49             # Collect Statistics:
50             self.action_counts = [{act:0 for act in game.actions[i]} for i in
                range(game.num_players)]
51             self.reward_sum = [0 for i in range(game.num_players)]
52             self.dist = {}
53             self.dist_history = []
54             self.actions = tuple(ag.initial_action(game.initial_state) for ag
                in self.agents)
55             self.num_steps = 0
56
57         def go(self, steps):
58             for i in range(steps):
59                 self.num_steps += 1
60                 (rewards, state) = self.game.play(self.actions)
61                 self.display(3, f"In go {rewards=}, {state=}")

```

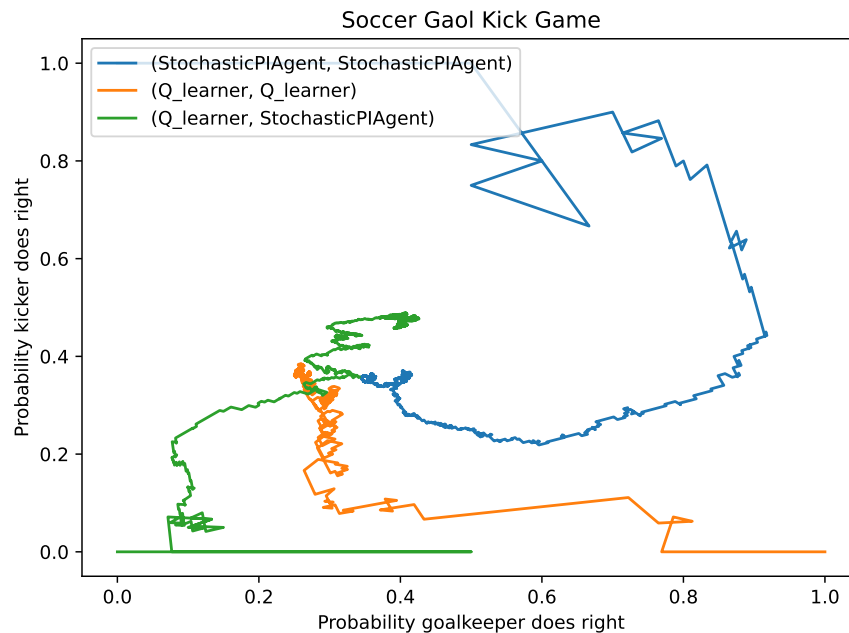

Figure 14.3: Dynamics of three runs of SoccerGame

```

62     self.reward_sum = [self.reward_sum[i]+rewards[i] for i in
63         range(len(rewards))]
64     self.actions = tuple(agent.select_action(reward, state)
65         for (agent,reward) in
66             zip(self.agents,rewards))
67     for i in range(self.game.num_players):
68         self.action_counts[i][self.actions[i]] += 1
69     self.dist_history.append([[a:i/self.num_steps for (a,i) in
70         elt.items()
71         for elt in self.action_counts])
72     self.display(1,"Scores:", ' '.join(
73         f"{self.agents[i].name} average
74         reward={self.reward_sum[i]/self.num_steps}"
75         for i in range(self.game.num_players)))
76     self.display(1,"Distributions:",
77         ' '.join(str({a:self.dist_history[-1][i][a]
78             /sum(self.dist_history[-1][i].values())
79             for a in self.game.actions[i]})
80             for i in range(self.game.num_players)))

```

The plot shows how the empirical distributions of two actions by two agents changes as the learning continues.

Figure 14.3 shows the plot of 3 runs. The first (blue) run, where both agents are running stochastic policy iteration, starts with the goalkeeper going left

and the kicker going right; it ends with both probabilities around 0.35. The second (orange) run, where both agents are doing Q-learning, starts with the goalkeeper going right and the kicker going left; it ends with empirical probabilities of 0.24 for the goalkeeper going right and 0.36 for the kicker going right. The third (green) run, where the goalkeeper is doing Q-learning and the kicker is doing stochastic policy iteration, starts both players going left; it ends with empirical probabilities of 0.41 for the goalkeeper going right and 0.46 for the kicker going right. (You can tell the start as the empirical distribution starts with 0 or 1 probabilities, and moves quickly initially.) This figure is generated using the commented out code at the end of `masLearn.py`.

```

masLearn.py — (continued)
78 def plot_dynamics(self, x_ag=0, y_ag=1, x_action=0, y_action=0):
79     """ plot how the empirical probabilities vary
80     x_ag index of the agent on the x-axis
81     y_ag index of the agent on the y-axis
82     x_action index of the action plotted for x_ag
83     y_action index of the action plotted for y_ag
84     """
85     plt.ion() # make it interactive
86     ax.set_title(self.game.name)
87     x_act = self.game.actions[x_ag][x_action]
88     y_act = self.game.actions[y_ag][y_action]
89     ax.set_xlabel(f"Probability {self.game.players[x_ag]} does "
90                 f"{self.agents[x_ag].actions[x_action]}")
91     ax.set_ylabel(f"Probability {self.game.players[y_ag]} does "
92                 f"{self.agents[y_ag].actions[y_action]}")
93     ax.plot([self.dist_history[i][x_ag][x_act]
94             for i in range(len(self.dist_history))],
95            [self.dist_history[i][y_ag][y_act]
96             for i in range(len(self.dist_history))],
97            label = f"({self.agents[x_ag].name},
98                  {self.agents[y_ag].name})")
99     ax.legend()
100    plt.show()
101 fig, ax = plt.subplots()

```

14.2.2 Example Games

The following are games from Poole and Mackworth [2023].

```

masLearn.py — (continued)
104 class ShoppingGame(Game):
105     def __init__(self):
106         Game.__init__(self, "Shopping Game",
107                       ['football-preferrer', 'shopping-preferrer'], #players
108                       [['shopping', 'football']]*2 # actions
109                       )

```

```

110
111     def play(self, actions):
112         """Given (action1,action2) returns (resulting_state, (reward1,
113             reward2))
114             """
115         return ({('football', 'football'): (2, 1),
116             ('football', 'shopping'): (0, 0),
117             ('shopping', 'football'): (0, 0),
118             ('shopping', 'shopping'): (1, 2)
119             }[actions], 's')
120
121 class SoccerGame(Game):
122     def __init__(self):
123         Game.__init__(self, "Soccer Gaol Kick Game",
124             ['goalkeeper', 'kicker'], # players
125             [['right', 'left']]*2 # actions
126             )
127
128     def play(self, actions):
129         """Given (action1,action2) returns (resulting_state, (reward1,
130             reward2))
131             resulting state is 's'
132             """
133         return ({('left', 'left'): (0.6, 0.4),
134             ('left', 'right'): (0.3, 0.7),
135             ('right', 'left'): (0.2, 0.8),
136             ('right', 'right'): (0.9,0.1)
137             }[actions], 's')
138
139 class GameShow(Game):
140     def __init__(self):
141         Game.__init__(self, "Game Show (prisoners dilemma)",
142             ['Agent 1', 'Agent 2'], # players
143             [['takes', 'gives']]*2 # actions
144             )
145
146     def play(self, actions):
147         return ({('takes', 'takes'): (1, 1),
148             ('takes', 'gives'): (11, 0),
149             ('gives', 'takes'): (0, 11),
150             ('gives', 'gives'): (10, 10)
151             }[actions], 's')
152
153 class UniqueNEGameExample(Game):
154     def __init__(self):
155         Game.__init__(self, "3x3 Unique NE Game Example",
156             ['agent 1', 'agent 2'], # players
157             [['a1', 'b1', 'c1'],['d2', 'e2', 'f2']]

```

```

158     def play(self, actions):
159         return ({('a1', 'd2'): (3, 5),
160                 ('a1', 'e2'): (5, 1),
161                 ('a1', 'f2'): (1, 2),
162                 ('b1', 'd2'): (1, 1),
163                 ('b1', 'e2'): (2, 9),
164                 ('b1', 'f2'): (6, 4),
165                 ('c1', 'd2'): (2, 6),
166                 ('c1', 'e2'): (4, 7),
167                 ('c1', 'f2'): (0, 8)
168                }[actions], 's')

```

14.2.3 Testing Games and Environments

```

masLearn.py — (continued)
170 # Choose a game:
171 # gm = ShoppingGame()
172 # gm = SoccerGame()
173 # gm = GameShow()
174 # gm = UniqueNEGameExample()
175
176 from rlQLearner import Q_learner
177 from rlProblem import RL_agent
178 from rlStochasticPolicy import StochasticPIAgent
179 # Choose one of the combinations of learners:
180 # sm = gm.sim([StochasticPIAgent, StochasticPIAgent]); sm.go(10000)
181 # sm = gm.sim([Q_learner, Q_learner]); sm.go(10000)
182 # sm = gm.sim([Q_learner, StochasticPIAgent]); sm.go(10000)
183 # sm = gm.sim([StochasticPIAgent, Q_learner]); sm.go(10000)
184
185 # sm.plot_dynamics()

```

Exercise 14.3 Consider a pair of controllers for a games (try multiple controllers and games, including the soccer game). Does the empirical distribution represent a Nash equilibrium? Would either agent be better off if they played a Nash equilibrium instead of the empirical distribution? [10000 steps might not be enough for the algorithm to converge.]

Exercise 14.4 Try the Game Show (prisoner’s dilemma) with two `StochasticPIAgent` agents and `alpha_fun=lambda k:0.1`, and also with other values of `k`, including `0.01`. Do different values of `k` work qualitatively differently? Explain why. Is one better? Try other games and other algorithms.

Exercise 14.5 Consider the alternative ways to implement stochastic policy iteration of Exercise 13.4.

- (a) What value(s) of c converge for the soccer game? Explain your results.
- (b) Suggest another method that works well for the soccer game, the other games and other RL environments.

Exercise 14.6 For the soccer game, how can a Q_learner be regularly beaten? Assume that the random number generator is secret. (Hint: can you predict what it will do?) What happens when it is played against an adversary that knows how it learns? What happens if two of these agents are played against each other? Can a StochasticPIAgent be defeated in the same way?

Individuals and Relations

Here we implement top-down proofs for Datalog and logic programming. This is much less efficient than Prolog, which is typically implemented by compiling to an abstract machine. If you want to do serious work, we suggest using Prolog; SWI Prolog (<https://www.swi-prolog.org>) is good.

15.1 Representing Datalog and Logic Programs

The following extends the knowledge bases of Chapter 5 to include logical variables. In that chapter, atoms did not have structure and were represented as strings. Here atoms can have arguments including variables (defined below) and constants (represented by strings).

Function symbols have the same representation as atoms. To make unification simpler and to allow treating clauses as data, `Func` is defined as an abbreviation for `Atom`.

```
_____logicRelation.py — Datalog and Logic Programs_____
11 from display import Displayable
12 import logicProblem
13
14 class Var(Displayable):
15     """A logical variable"""
16     def __init__(self, name):
17         """name"""
18         self.name = name
19
20     def __str__(self):
21         return self.name
```

```

22     __repr__ = __str__
23
24     def __eq__(self, other):
25         return isinstance(other, Var) and self.name == other.name
26     def __hash__(self):
27         return hash(self.name)
28
29 class Atom(object):
30     """An atom"""
31     def __init__(self, name, args):
32         self.name = name
33         self.args = args
34
35     def __str__(self):
36         return f"{self.name}({' ', ' '.join(str(a) for a in self.args)})"
37     __repr__ = __str__
38
39 Func = Atom # same syntax is used for function symbols

```

The following extends Clause of Section 5.1 to include also a set of logical variables in the clause. It also allows for atoms that are strings (as in Chapter 5) and makes them into atoms.

```

_____logicRelation.py — (continued)_____
41 class Clause(logicProblem.Clause):
42     next_index=0
43     def __init__(self, head, *args, **nargs):
44         if not isinstance(head, Atom):
45             head = Atom(head)
46         logicProblem.Clause.__init__(self, head, *args, **nargs)
47         self.logical_variables = log_vars([self.head, self.body], set())
48
49     def rename(self):
50         """create a unique copy of the clause"""
51         if self.logical_variables:
52             sub = {v:Var(f"{v.name}_{Clause.next_index}") for v in
53                   self.logical_variables}
54             Clause.next_index += 1
55             return Clause(apply(self.head, sub), apply(self.body, sub))
56         else:
57             return self
58
59 def log_vars(exp, vs):
60     """the union the logical variables in exp and the set vs"""
61     if isinstance(exp, Var):
62         return {exp}|vs
63     elif isinstance(exp, Atom):
64         return log_vars(exp.name, log_vars(exp.args, vs))
65     elif isinstance(exp, (list, tuple)):
66         for e in exp:
67             vs = log_vars(e, vs)

```

67 | `return vs`

15.2 Unification

The unification algorithm is very close to the pseudocode of Section 15.5.3 of Poole and Mackworth [2023].

```

logicRelation.py — (continued)
69 unifdisp = Var(None) # for display
70
71 def unify(t1,t2):
72     e = [(t1,t2)]
73     s = {} # empty dictionary
74     while e:
75         (a,b) = e.pop()
76         unifdisp.display(2,f"unifying{(a,b)}, e={e},s={s}")
77         if a != b:
78             if isinstance(a,Var):
79                 e = apply(e,{a:b})
80                 s = apply(s,{a:b})
81                 s[a]=b
82             elif isinstance(b,Var):
83                 e = apply(e,{b:a})
84                 s = apply(s,{b:a})
85                 s[b]=a
86             elif isinstance(a,Atom) and isinstance(b,Atom) and
87                 a.name==b.name and len(a.args)==len(b.args):
88                 e += zip(a.args,b.args)
89             elif isinstance(a,(list,tuple)) and isinstance(b,(list,tuple))
90                 and len(a)==len(b ):
91                 e += zip(a,b)
92             else:
93                 return False
94         return s
95
96 def apply(e,sub):
97     """e is an expression
98     sub is a {var:val} dictionary
99     returns e with all occurrence of var replaces with val"""
100    if isinstance(e,Var) and e in sub:
101        return sub[e]
102    if isinstance(e,Atom):
103        return Atom(e.name, apply(e.args,sub))
104    if isinstance(e,list):
105        return [apply(a,sub) for a in e]
106    if isinstance(e,tuple):
107        return tuple(apply(a,sub) for a in e)
108    if isinstance(e,dict):
109        return {k:apply(v,sub) for (k,v) in e.items()}

```

```

108     else:
109         return e

```

Test cases:

```

----- logicRelation.py — (continued) -----
111 ### Test cases:
112 # unifdisp.max_display_level = 2 # show trace
113 e1 = Atom('p', [Var('X'), Var('Y'), Var('Y')])
114 e2 = Atom('p', ['a', Var('Z'), 'b'])
115 # apply(e1, {Var('Y'): 'b'})
116 # unify(e1, e2)
117 e3 = Atom('p', ['a', Var('Y'), Var('Y')])
118 e4 = Atom('p', [Var('Z'), Var('Z'), 'b'])
119 # unify(e3, e4)

```

15.3 Knowledge Bases

The following modifies KB of Section 5.1 so that clause indexing is only on the predicate symbol of the head of clauses.

```

----- logicRelation.py — (continued) -----
121 class KB(logicProblem.KB):
122     """A first-order knowledge base.
123         only the indexing is changed to index on name of the head."""
124
125     def add_clause(self, c):
126         """Add clause c to clause dictionary"""
127         if c.head.name in self.atom_to_clauses:
128             self.atom_to_clauses[c.head.name].append(c)
129         else:
130             self.atom_to_clauses[c.head.name] = [c]

```

simp_KB is the simple knowledge base of Figure 15.1 of Poole and Mackworth [2023].

```

----- relnExamples.py — Relational Knowledge Base Example -----
11 from logicRelation import Var, Atom, Clause, KB
12
13 simp_KB = KB([
14     Clause(Atom('in', ['kim', 'r123'])),
15     Clause(Atom('part_of', ['r123', 'cs_building'])),
16     Clause(Atom('in', [Var('X'), Var('Y')]),
17             [Atom('part_of', [Var('Z'), Var('Y')]),
18              Atom('in', [Var('X'), Var('Z')])])
19 ])

```

elect_KB is the relational version of the knowledge base for the electrical system of a house, as described in Example 15.11 of Poole and Mackworth [2023].

relnExamples.py — (continued)

```

21 # define abbreviations to make the clauses more readable:
22 def lit(x): return Atom('lit',[x])
23 def light(x): return Atom('light',[x])
24 def ok(x): return Atom('ok',[x])
25 def live(x): return Atom('live',[x])
26 def connected_to(x,y): return Atom('connected_to',[x,y])
27 def up(x): return Atom('up',[x])
28 def down(x): return Atom('down',[x])
29
30 L = Var('L')
31 W = Var('W')
32 W1 = Var('W1')
33
34 elect_KB = KB([
35     # lit(L) is true if light L is lit.
36     Clause(lit(L),
37            [light(L),
38             ok(L),
39             live(L)]),
40
41     # live(W) is true if W is live (i.e., current will flow through it)
42     Clause(live(W),
43            [connected_to(W,W1),
44             live(W1)]),
45
46     Clause(live('outside')),
47
48     # light(L) is true if L is a light
49     Clause(light('l1')),
50     Clause(light('l2')),
51
52     # connected_to(W0,W1) is true if W0 is connected to W1 such that
53     # current will flow from W1 to W0.
54
55     Clause(connected_to('l1','w0')),
56     Clause(connected_to('w0','w1'),
57            [ up('s2'), ok('s2')]),
58     Clause(connected_to('w0','w2'),
59            [ down('s2'), ok('s2')]),
60     Clause(connected_to('w1','w3'),
61            [ up('s1'), ok('s1')]),
62     Clause(connected_to('w2','w3'),
63            [ down('s1'), ok('s1')]),
64     Clause(connected_to('l2','w4')),
65     Clause(connected_to('w4','w3'),
66            [ up('s3'), ok('s3')]),
67     Clause(connected_to('p1','w3')),
68     Clause(connected_to('w3','w5'),
69            [ ok('cb1')]),

```

```

70     Clause(connected_to('p2', 'w6')),
71     Clause(connected_to('w6', 'w5'),
72           [ ok('cb2')]),
73     Clause(connected_to('w5', 'outside'),
74           [ ok('outside_connection')]),
75
76     # up(S) is true if switch S is up
77     # down(S) is true if switch S is down
78     Clause(down('s1')),
79     Clause(up('s2')),
80     Clause(up('s3')),
81
82     # ok(L) is true if K is working. Everything is ok:
83     Clause(ok(L)),
84 ])
```

15.4 Top-down Proof Procedure

The top-down proof procedure is the one defined in Section 15.5.4 of Poole and Mackworth [2023] and shown in Figure 15.5. It is like `prove` defined in Section 5.3. It implements the iterator interface so that answers can be generated one at a time (or put in a list), and returns answers. To implement “choose” it loops over all alternatives and *yields* (returns one element at a time) the successful proofs.

```

_____logicRelation.py — (continued)_____
132     def ask(self, query):
133         """self is the current KB
134         query is a list of atoms to be proved
135         generates {variable:value} dictionary"""
136
137         qvars = list(log_vars(query, set()))
138         for ans in self.prove(qvars, query):
139             yield {x:v for (x,v) in zip(qvars,ans)}
140
141     def ask_all(self, query):
142         """returns a list of all answers to the query given kb"""
143         return list(self.ask(query))
144
145     def ask_one(self, query):
146         """returns an answer to the query given kb or None of there are no
147         answers"""
148         for ans in self.ask(query):
149             return ans
150
151     def prove(self, ans, ans_body, indent=""):
152         """enumerates the proofs for ans_body
153         ans_body is a list of atoms to be proved
```

```

153     ans is the list of values of the query variables
154     """
155     self.display(2,indent,f"(yes({ans}) <-", " & ".join(str(a) for a in
        ans_body))
156     if ans_body==[]:
157         yield ans
158     else:
159         selected, remaining = self.select_atom(ans_body)
160         if self.built_in(selected):
161             yield from self.eval_built_in(ans, selected, remaining,
                indent)
162         else:
163             for chosen_clause in self.atom_to_clauses[selected.name]:
164                 clause = chosen_clause.rename() # rename variables
165                 sub = unify(selected, clause.head)
166                 if sub is not False:
167                     self.display(3,indent,"KB.prove: selected=",
                        selected, "clause=",clause,"sub=",sub)
168                     resans = apply(ans,sub)
169                     new_ans_body = apply(clause.body+remaining, sub)
170                     yield from self.prove(resans, new_ans_body, indent+"
                        ")
171
172     def select_atom(self,lst):
173         """given list of atoms, return (selected atom, remaining atoms)
174         """
175         return lst[0],lst[1:]
176
177     def built_in(self,atom):
178         return atom.name in ['lt','triple']
179
180     def eval_built_in(self,ans, selected, remaining, indent):
181         if selected.name == 'lt': # less than
182             [a1,a2] = selected.args
183             if a1 < a2:
184                 yield from self.prove(ans, remaining, indent+" ")
185         if selected.name == 'triple': # use triple store (AIFCA Ch 16)
186             yield from self.eval_triple(ans, selected, remaining, indent)

```

The unit test run when loading is the query $in(A, B)$, from `simp_KB`. It should have two answers.

relnExamples.py — (continued)

```

86 # Example Queries:
87 # simp_KB.max_display_level = 2 # show trace
88 # ask_all(simp_KB, [Atom('in',[Var('A'),Var('B')])])
89
90 A = Var('A')
91 B = Var('B')
92
93 def test_ask_all(kb=simp_KB,

```

```

94         query=[Atom('in',[A,B])],
95         res=[{ A:'kim',B:'r123'}, {A:'kim',B: 'cs_building'}]:
96     ans= kb.ask_all(query)
97     assert ans == res, f"ask_all({query}) gave answer {ans}"
98     print("ask_all: Passed unit test")
99
100 if __name__ == "__main__":
101     test_ask_all()
102
103 # elect_KB.max_display_level = 2 # show trace
104 # elect_KB.ask_all([light('l1')])
105 # elect_KB.ask_all([light('l6')])
106 # elect_KB.ask_all([up(Var('X'))])
107 # elect_KB.ask_all([connected_to('w0',W)])
108 # elect_KB.ask_all([connected_to('w1',W)])
109 # elect_KB.ask_all([connected_to(W,'w3')])
110 # elect_KB.ask_all([connected_to(W1,W)])
111 # elect_KB.ask_all([live('w6')])
112 # elect_KB.ask_all([live('p1')])
113 # elect_KB.ask_all([Atom('lit',[L])])
114 # elect_KB.ask_all([Atom('lit',[l2']), live('p1')])
115 # elect_KB.ask_all([live(L)])

```

Exercise 15.1 Implement ask-the-user similar to Section 5.3. Augment this by allowing the user to specify which instances satisfy an atom. For example, by asking the user "for what X is w1 connected to X?"; or perhaps in a more user friendly way.

15.5 Logic Program Example

The following is an append program and the query of Example 15.30 of Poole and Mackworth [2023].

```

append(nil,W,W).
append(c(A,X),Y,c(A,Z)) <-
    append(X,Y,Z).

```

The term $c(A,X)$ is represented using Atom

In Prolog syntax:

```

append(nil,W,W).
append([A|X],Y,[A|Z]) :-
    append(X,Y,Z).

```

The value if lst is [l, i, s, t]. The query is

```
? append(F,[L],[l,i,s,t]).
```

We first define some constants and functions to make it more readable.

```
logicRelation.py — (continued)
188 A = Var('A')
189 F = Var('F')
190 L = Var('L')
191 W = Var('W')
192 X = Var('X')
193 Y = Var('Y')
194 Z = Var('Z')
195 def cons(h,t): return Atom('cons',[h,t])
196 def append(a,b,c): return Atom('append',[a,b,c])
197
198 app_KB = KB([
199     Clause(append('nil',W,W)),
200     Clause(append(cons(A,X), Y,cons(A,Z)),
201             [append(X,Y,Z)])
202 ])
203
204
205 lst = cons('l',cons('i',cons('s',cons('t','nil'))))
206 # app_KB.max_display_level = 2 #show derivation
207 #app_KB.ask_all([append(F,cons(A,'nil'), lst)])
208 # Think about the expected answer before trying:
209 #app_KB.ask_all([append(X, Y, lst)])
210 #app_KB.ask_all([append(lst, lst, L), append(X, cons('s',Y), L)])
```

Knowledge Graphs and Ontologies

16.1 Triple Store

A triple store provides efficient indexing for triples. For any combination of the subject-verb-object being provided or not, it can efficiently retrieve the corresponding triples. This should be comparable in speed to commercial in-memory triple stores. It handles fewer triples, as it is not optimized for space, and only has in-memory storage. It also has fewer bells and whistles (e.g., ways to visualize triples and traverse the graph).

A triple store implements an index that covers all cases of where the subject, verb, or object are provided or not. The unspecified parts are given using Q (with value '?'). Thus, for example, `index[(Q, vrb, Q)]` is the list of triples with verb `vrb`. `index[(sub, Q, obj)]` is the list of triples with subject `sub` and object `obj`.

```
_____knowledgeGraph.py — Knowledge graph triple store_____
11 from display import Displayable
12
13 class TripleStore(Displayable):
14     Q = '?' # query position
15
16     def __init__(self):
17         self.index = {}
18
19     def add(self, triple):
20         (sb,vb,ob) = triple
21         Q = self.Q # make it easier to read
22         add_to_index(self.index, (Q,Q,Q), triple)
```

```

23     add_to_index(self.index, (Q,Q,ob), triple)
24     add_to_index(self.index, (Q,vb,Q), triple)
25     add_to_index(self.index, (Q,vb,ob), triple)
26     add_to_index(self.index, (sb,Q,Q), triple)
27     add_to_index(self.index, (sb,Q,ob), triple)
28     add_to_index(self.index, (sb,vb,Q), triple)
29     add_to_index(self.index, triple, triple)
30
31     def __len__(self):
32         """number of triples in the triple store"""
33         return len(self.index[(Q,Q,Q)])

```

The lookup method returns a list of triples that match a pattern. The pattern is a triple of the form (i, j, k) where each of i , j , and k is either “Q” or a given value; specifying whether the subject, verb, and object are provided in the query or not. `lookup((Q,Q,Q))` returns all triples. `lookup((s,v,o))` can be used to check whether the triple (s, v, o) is in the triple store; it returns `[]` if the triple is not in the knowledge graph, and `[(s, v, o)]` if it is.

```

_____knowledgeGraph.py — (continued)_____
35     def lookup(self, query):
36         """pattern is a triple of the form (i,j,k) where
37             each i, j, k is either Q or a value for the
38             subject, verb and object respectively.
39             returns all triples with the specified non-Q vars in corresponding
              position
40         """
41         if query in self.index:
42             return self.index[query]
43         else:
44             return []
45
46     def add_to_index(dict, key, value):
47         if key in dict:
48             dict[key].append(value)
49         else:
50             dict[key] = [value]

```

Here is a simple test triple store. In Wikidata Q262802 denotes the football (soccer) player Christine Sinclair, P27 is the country of citizenship, and Q16 is Canada.

```

_____knowledgeGraph.py — (continued)_____
52 # test cases:
53 sts = TripleStore() # simple triple store
54 Q = TripleStore.Q # makes it easier to read
55 sts.add(('entity/Q262802', 'http://schema.org/name', "Christine Sinclair"))
56 sts.add(('entity/Q262802', '/prop/direct/P27', '/entity/Q16'))
57 sts.add(('entity/Q16', 'http://schema.org/name', "Canada"))
58
59 # sts.lookup(('entity/Q262802', Q, Q))

```

```

60 # sts.lookup((Q,'http://schema.org/name',Q))
61 # sts.lookup((Q,'http://schema.org/name',"Canada"))
62 # sts.lookup(('entity/Q16', 'http://schema.org/name', "Canada"))
63 # sts.lookup(('entity/Q262802', 'http://schema.org/name', "Canada"))
64 # sts.lookup((Q,Q,Q))
65
66 def test_kg(kg=sts, q=('entity/Q262802',Q,Q),
67     res=[('entity/Q262802','http://schema.org/name',"Christine
68     Sinclair"), ('entity/Q262802', '/prop/direct/P27','entity/Q16')]):
69     """Knowledge graph unit test"""
70     ans = kg.lookup(q)
71     assert res==ans, f"test_kg answer {ans}"
72     print("knowledge graph unit test passed")
73
74 if __name__ == "__main__":
75     test_kg()

```

To read rdf files, you can use rdflib (<https://rdflib.readthedocs.io/en/stable/>).

The default in `load_file` is to include only English names; multiple languages can be included in the list. If the language restriction is `None`, all tuples are included. Converting to strings, as done here, loses information, e.g., the language associated with the literals. If you don't want to lose information, you can use rdflib objects, by omitting `str` in the call to `ts.add`.

knowledgeGraph.py — (continued)

```

75 # before using do:
76 # pip install rdflib
77
78 def load_file(ts, filename, language_restriction=['en']):
79     import rdflib
80     g = rdflib.Graph()
81     g.parse(filename)
82     for (s,v,o) in g:
83         if language_restriction and isinstance(o,rdflib.term.Literal) and
84             o._language and o._language not in language_restriction:
85             pass
86         else:
87             ts.add((str(s),str(v),str(o)))
88     print(f"{len(g)} triples read. Triple store has {len(ts)} triples.")
89
90 TripleStore.load_file = load_file
91
92 ##### Test cases #####
93 ts = TripleStore()
94 #ts.load_file('http://www.wikidata.org/wiki/Special:EntityData/Q262802.nt')
95 q262802 = 'http://www.wikidata.org/entity/Q262802'
96 #res=ts.lookup((q262802, 'http://www.wikidata.org/prop/P27',Q)) # country
97     of citizenship
98 # The attributes of the object in the first answer to the above query:

```

```

97 #ts.lookup((res[0][2],Q,Q))
98 #ts.lookup((q262802, 'http://www.wikidata.org/prop/P54',Q)) # member of
    sports team
99 #ts.lookup((q262802, 'http://schema.org/name',Q))

```

16.2 Integrating Datalog and Triple Store

The following extends the definite clause reasoner in the previous chapter to include a built-in “triple” predicate (an atom with name “triple” and three arguments). The instances of this predicate are retrieved from the triple store. This is a simplified version of what can be done with the `semweb` library of SWI Prolog ([https://www.swi-prolog.org/pldoc/doc_for?object=section\(%27packages/semweb.html%27\)](https://www.swi-prolog.org/pldoc/doc_for?object=section(%27packages/semweb.html%27))). For anything serious, we suggest you use that. Note that the `semweb` library uses “`rdf`” as the predicate name, and Poole and Mackworth [2023] uses “`prop`” in Section 16.1.3 for the same predicate as “triple”.

```

_____knowledgeReasoning.py — Integrating Datalog and triple store _____
11 from logicRelation import Var, Atom, Clause, KB, unify, apply
12 from knowledgeGraph import TripleStore, sts
13 import random
14
15 class KBT(KB):
16     def __init__(self, triplestore, statements=[]):
17         self.triplestore = triplestore
18         KB.__init__(self, statements)
19
20     def eval_triple(self, ans, selected, remaining, indent):
21         query = selected.args
22         Q = self.triplestore.Q
23         pattern = tuple(Q if isinstance(e,Var) else e for e in query)
24         retrieved = self.triplestore.lookup(pattern)
25         self.display(3,indent,"eval_triple:
26             query=",query,"pattern=",pattern,"retrieved=",retrieved)
27         for tr in random.sample(retrieved,len(retrieved)):
28             sub = unify(tr, query)
29             self.display(3,indent,"KB.prove:
30                 selected=",selected,"triple=",tr,"sub=",sub)
31             if sub is not False:
32                 yield from self.prove(apply(ans,sub), apply(remaining,sub),
33                     indent+" ")
34
35 # simple test case:
36 kbt = KBT(sts) # sts is simple triplestore from knowledgeGraph.py
37 # kbt.ask_all([Atom('triple'),('http://www.wikidata.org/entity/Q262802',
38     Var('P'),Var('O')))])

```

The following are some larger examples from Wikidata. You must run `load_file` to load the triples related to Christine Sinclair (Q262802). Otherwise the queries won’t work.

The first query is how Christine Sinclair (Q262802) is related to Portland Thorns (Q1446672) with two hops in the knowledge graph. It is asking for a P , O and $P1$ such that

$$(Q262802, P, O) \& (O, P1, Q1446672)$$

```

_____knowledgeReasoning.py — (continued)_____
36 O = Var('O'); O1 = Var('O1')
37 P = Var('P')
38 P1 = Var('P1')
39 T = Var('T')
40 N = Var('N')
41 def triple(s,v,o): return Atom('triple',[s,v,o])
42 def lt(a,b): return Atom('lt',[a,b])
43
44 ts = TripleStore()
45 kbts = KBT(ts)
46 #ts.load_file('http://www.wikidata.org/wiki/Special:EntityData/Q262802.nt')
47 q262802 = 'http://www.wikidata.org/entity/Q262802'
48 # How is Christine Sinclair (Q262802) related to Portland Thorns
   (Q1446672) with 2 hops:
49 # kbts.ask_all([triple(q262802, P, O), triple(O, P1,
   'http://www.wikidata.org/entity/Q1446672') ])

```

The second is asking for the name of a team that Christine Sinclair (Q262802) played for. It is asking for a O , T and N , where O is the reified object that gives the relationship, T is the team and N is the name of the team. Informally (with variables starting with uppercase and constants in lower case) this is

$$(q262802, p54, O) \& (O, p54, T) \& (T, name, N)$$

Notice how the reified relation 'P54' (member of sports team) is represented:

```

_____knowledgeReasoning.py — (continued)_____
51 # What is the name of a team that Christine Sinclair played for:
52 # kbts.ask_one([triple(q262802, 'http://www.wikidata.org/prop/P54',O),
   triple(O, 'http://www.wikidata.org/prop/statement/P54',T),
   triple(T, 'http://schema.org/name',N)])

```

The third asks for the name of a team that Christine Sinclair (Q262802) played for at two different start times. It is asking for a N , $D1$ and $D2$, N is the name of the team and $D1$ and $D2$ are the start dates. In Wikidata, P54 is "member of sports team" and P580 is "start time".

```

_____knowledgeReasoning.py — (continued)_____
54 # The name of a team that Christine Sinclair played for at two different
   times, and the dates
55 def playedtwice(s,n,d0,d1): return Atom('playedtwice',[s,n,d0,d1])
56 S = Var('S')
57 N = Var('N')

```

```
58 D0 = Var('D0')
59 D1 = Var('D2')
60
61 kbts.add_clause(Clause(playedtwice(S,N,D0,D1), [
62     triple(S, 'http://www.wikidata.org/prop/P54', 0),
63     triple(0, 'http://www.wikidata.org/prop/statement/P54', T),
64     triple(S, 'http://www.wikidata.org/prop/P54', 01),
65     triple(01, 'http://www.wikidata.org/prop/statement/P54', T),
66     lt(0,01), # ensure different and only generated once
67     triple(T, 'http://schema.org/name', N),
68     triple(0, 'http://www.wikidata.org/prop/qualifier/P580', D0),
69     triple(01, 'http://www.wikidata.org/prop/qualifier/P580', D1)
70 ]))
71
72 # kbts.ask_all([playedtwice(q262802,N,D0,D1)])
```

Relational Learning

17.1 Collaborative Filtering

The code here is based on the gradient descent algorithm for matrix factorization of Koren, Bell, and Volinsky [2009].

A rating set consists of training and test data, each a list of $(user, item, rating)$ tuples.

```
_____relnCollFilt.py — Latent Property-based Collaborative Filtering _____
11 import random
12 import matplotlib.pyplot as plt
13 import urllib.request
14 from learnProblem import Learner
15 from display import Displayable
16
17 class Rating_set(Displayable):
18     """A rating contains:
19     training_data: list of (user, item, rating) triples
20     test_data: list of (user, item, rating) triples
21     """
22     def __init__(self, training_data, test_data):
23         self.training_data = training_data
24         self.test_data = test_data
```

The following is a representation of Examples 17.5-17.7 of Poole and Mackworth [2023]. This is a much smaller dataset than one would expect to work well.

```
_____relnCollFilt.py — (continued) _____
26 grades_rs = Rating_set( # 3='A', 2='B', 1='C'
27     [('s1','c1',3), # training data
28     ('s2','c1',1),
```

```

29     ('s1', 'c2', 2),
30     ('s2', 'c3', 2),
31     ('s3', 'c2', 2),
32     ('s4', 'c3', 2)],
33     [('s3', 'c4', 3), # test data
34      ('s4', 'c4', 1)])

```

A CF_learner does stochastic gradient descent to make a predictor of ratings for user-item pairs.

```

_____relnCollFilt.py — (continued) _____
36 class CF_learner(Learner):
37     def __init__(self,
38                 rating_set,          # a Rating_set
39                 step_size = 0.01,    # gradient descent step size
40                 regularization = 1.0, # L2 regularization for full dataset
41                 num_properties = 10, # number of hidden properties
42                 property_range = 0.02 # properties are initialized to be
                                     # between
43                                     # -property_range and property_range
44                 ):
45         self.rating_set = rating_set
46         self.training_data = rating_set.training_data
47         self.test_data = self.rating_set.test_data
48         self.step_size = step_size
49         self.regularization = regularization
50         self.num_properties = num_properties
51         self.num_ratings = len(self.training_data)
52         self.ave_rating = (sum(r for (u,i,r) in self.training_data)
53                            /self.num_ratings)
54         self.users = {u for (u,i,r) in self.training_data}
55         self.items = {i for (u,i,r) in self.training_data}
56         self.user_bias = {u:0 for u in self.users}
57         self.item_bias = {i:0 for i in self.items}
58         self.user_prop = {u:[random.uniform(-property_range,property_range)
59                               for p in range(num_properties)]
60                            for u in self.users}
61         self.item_prop = {i:[random.uniform(-property_range,property_range)
62                               for p in range(num_properties)]
63                            for i in self.items}
64         # the _delta variables are the changes internal to a batch:
65         self.user_bias_delta = {u:0 for u in self.users}
66         self.item_bias_delta = {i:0 for i in self.items}
67         self.user_prop_delta = {u:[0 for p in range(num_properties)]
68                                  for u in self.users}
69         self.item_prop_delta = {i:[0 for p in range(num_properties)]
70                                  for i in self.items}
71         # zeros is used for users and items not in the training set
72         self.zeros = [0 for p in range(num_properties)]
73         self.epoch = 0
74         self.display(1, "Predict mean:" "(Ave Abs,AveSumSq)",

```

```

75         "training =",self.eval2string(self.training_data,
76         useMean=True),
        "test =",self.eval2string(self.test_data, useMean=True))

```

prediction returns the current prediction of a user on an item.

```

relnCollFilt.py — (continued)
78 def prediction(self,user,item):
79     """Returns prediction for this user on this item.
80     The use of .get() is to handle users or items in test set but not
81     in the training set.
82     """
83     if user in self.user_bias: # user in training set
84         if item in self.item_bias: # item in training set
85             return (self.ave_rating
86                     + self.user_bias[user]
87                     + self.item_bias[item]
88                     + sum([self.user_prop[user][p]*self.item_prop[item][p]
89                           for p in range(self.num_properties)]))
90         else: # training set contains user but not item
91             return (self.ave_rating + self.user_bias[user])
92     elif item in self.item_bias: # training set contains item but not
93         user
94         return self.ave_rating + self.item_bias[item]
95     else:
96         return self.ave_rating

```

learn carries out num_epochs epochs of stochastic gradient descent with batch_size giving the number of training examples in a batch. The number of epochs is approximately the average number of times each training data point is used. It is approximate because it processes the integral number of the batch size.

```

relnCollFilt.py — (continued)
96 def learn(self, num_epochs = 50, batch_size=1000):
97     """ do (approximately) num_epochs iterations through the dataset
98     batch_size is the size of each batch of stochastic gradient
99     gradient descent.
100     """
101     batch_size = min(batch_size, len(self.training_data))
102     batch_per_epoch = len(self.training_data) // batch_size #
103     approximate
104     num_iter = batch_per_epoch*num_epochs
105     reglz =
106         self.step_size*self.regularization*batch_size/len(self.training_data)
107         #regularization per batch
108     for i in range(num_iter):
109         if i % batch_per_epoch == 0:
110             self.epoch += 1
111             self.display(1,"Epoch", self.epoch, "(Ave Abs,AveSumSq)",

```

```

109         "training =",self.eval2string(self.training_data),
110         "test =",self.eval2string(self.test_data))
111     # determine errors for a batch
112     for (user,item,rating) in random.sample(self.training_data,
113         batch_size):
114         error = self.prediction(user,item) - rating
115         self.user_bias_delta[user] += error
116         self.item_bias_delta[item] += error
117         for p in range(self.num_properties):
118             self.user_prop_delta[user][p] +=
119                 error*self.item_prop[item][p]
120             self.item_prop_delta[item][p] +=
121                 error*self.user_prop[user][p]
122     # Update all parameters
123     for user in self.users:
124         self.user_bias[user] -=
125             (self.step_size*self.user_bias_delta[user]
126              + reglz*self.user_bias[user])
127         self.user_bias_delta[user] = 0
128         for p in range(self.num_properties):
129             self.user_prop[user][p] -=
130                 (self.step_size*self.user_prop_delta[user][p]
131                  + reglz*self.user_prop[user][p])
132             self.user_prop_delta[user][p] = 0
133     for item in self.items:
134         self.item_bias[item] -=
135             (self.step_size*self.item_bias_delta[item]
136              + reglz*self.item_bias[item])
137         self.item_bias_delta[item] = 0
138         for p in range(self.num_properties):
139             self.item_prop[item][p] -=
140                 (self.step_size*self.item_prop_delta[item][p]
141                  + reglz*self.item_prop[item][p])
142             self.item_prop_delta[item][p] = 0

```

The evaluate method evaluates current predictions on the rating set:

```

relnCollFilt.py — (continued)
137 def evaluate(self, ratings, useMean=False):
138     """returns (average_absolute_error, average_sum_squares_error) for
139         ratings
140     """
141     abs_error = 0
142     sumsq_error = 0
143     if not ratings: return (0,0)
144     for (user,item,rating) in ratings:
145         prediction = self.ave_rating if useMean else
146             self.prediction(user,item)
147         error = prediction - rating
148         abs_error += abs(error)
149         sumsq_error += error * error

```

```

148         return abs_error/len(ratings), sumsq_error/len(ratings)
149
150     def eval2string(self, *args, **nargs):
151         """returns a string form of evaluate, with fewer digits
152         """
153         (abs,ssq) = self.evaluate(*args, **nargs)
154         return f"({abs:.4f}, {ssq:.4f})"

```

Let's test the code on the grades rating set:

```

relnCollFilt.py — (continued)
156 #lg = CF_learner(grades_rs,step_size = 0.1, regularization = 0.01,
157                 num_properties = 1)
158 #lg.learn(num_epochs = 500)
159 # lg.item_bias
160 # lg.user_bias
161 # lg.plot_property(0,plot_all=True) # can you explain why?

```

Exercise 17.1 In using `CF_learner` with `grades_rs`, does it work better with 0 properties? Is it overfitting to the data? How can overfitting be adjusted?

Exercise 17.2 Modify the code so that `self.ave_rating` is also learned. It should start as the average rating. Should it be regularized? Does it change from the initialized value? Does it work better or worse?

Exercise 17.3 With the Movielens 100K dataset and the batch size being the whole training set, what happens to the error? How can this be fixed?

Exercise 17.4 Can the regularization avoid iterating through the parameters for all users and items after a batch? Consider items that are in many batches versus those in a few or even no batches. (Warning: This is challenging to get right.)

17.1.1 Plotting

The `plot_predictions` method plots the cumulative distributions for each ground truth. Figure 17.1 shows a plot for the Movielens 100K dataset. Consider the `rating = 1` line. The value for x is the proportion of the predictions with predicted value $\leq x$ when the ground truth has a rating of 1. Similarly for the other lines.

Figure 17.1 is for one run on the training data. What would you expected the test data to look like?

```

relnCollFilt.py — (continued)
162     def plot_predictions(self, examples="test"):
163         """
164         examples is either "test" or "training" or the actual examples
165         """
166         if examples == "test":
167             theexamples = self.test_data
168         elif examples == "training":
169             theexamples = self.training_data

```

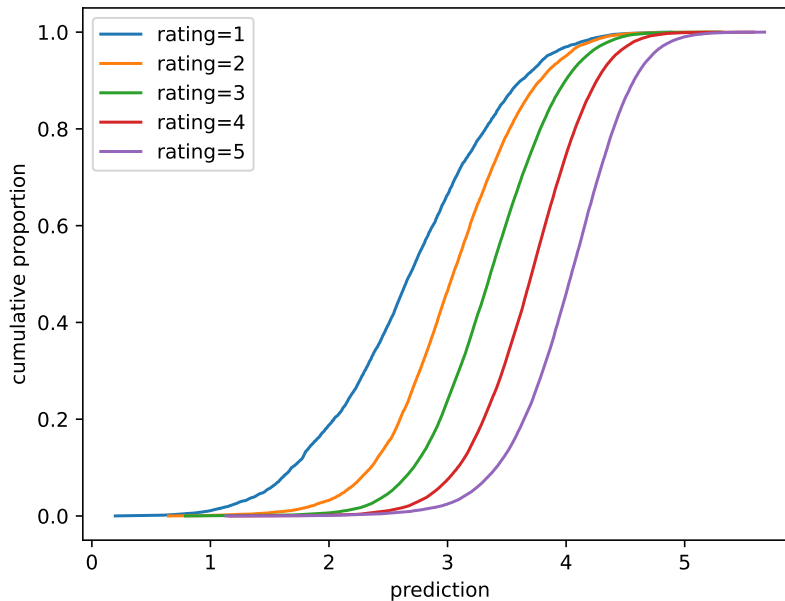

Figure 17.1: learner1.plot_predictions(examples = "training")

```

170     else:
171         theexamples = examples
172         plt.ion()
173         if not hasattr(self, 'ax'):
174             fig, self.ax = plt.subplots()
175             self.ax.set_xlabel("prediction")
176             self.ax.set_ylabel("cumulative proportion")
177             self.actuals = [[] for r in range(0,6)]
178             for (user,item,rating) in theexamples:
179                 self.actuals[rating].append(self.prediction(user,item))
180             for rating in range(1,6):
181                 self.actuals[rating].sort()
182                 numrat=len(self.actuals[rating])
183                 yvals = [i/numrat for i in range(numrat)]
184                 self.ax.plot(self.actuals[rating], yvals, label=f"{examples}
185                             rating={rating}")
186             self.ax.legend()
187             plt.draw()

```

The `plot_property` method plots a single latent property; see Figure 17.2. Each $(user, item, rating)$ is plotted where the x -value is the value of the property for the user, the y -value is the value of the property for the item, and the rating is plotted at this (x, y) position. That is, $rating$ is plotted at the (x, y) position $(p(user), p(item))$.

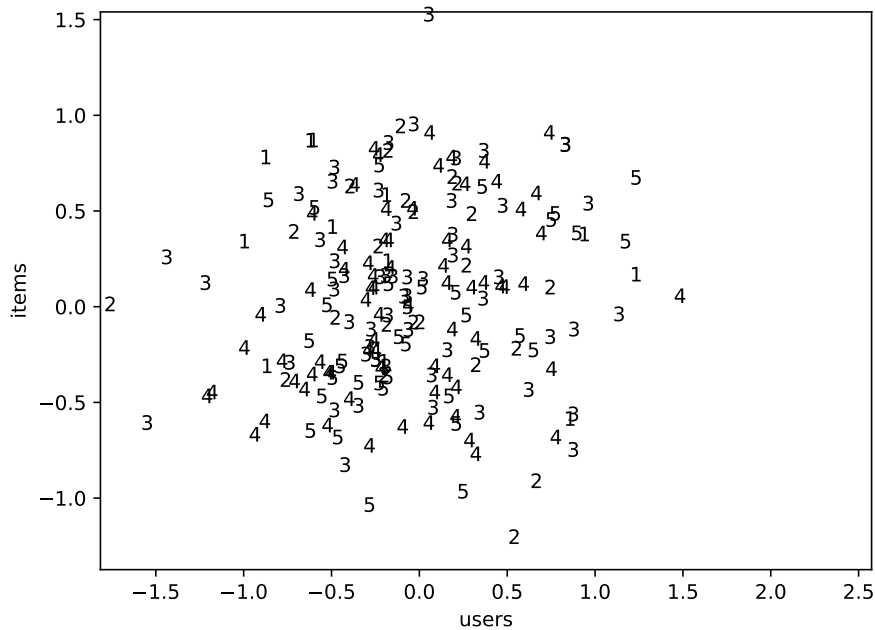

Figure 17.2: `learner1.plot_property(0)` with 200 random ratings plotted. Rating (u, i, r) has r plotted a position $(p(u), p(i))$ where p is the selected latent property.

Because there are too many ratings to show, `plot_property` selects a random number of points. It is difficult to see what is going on; the `create_top_subset` method was created to show the most rated items and the users who rated the most of these. This should help visualize how the latent property helps.

```

relnCollFilt.py — (continued)
188     def plot_property(self,
189                       p,                # property
190                       plot_all=False, # true if all points should be plotted
191                       num_points=200 # number of random points plotted if not
                                   all
192                       ):
193         """plot some of the user-movie ratings,
194         if plot_all is true
195         num_points is the number of points selected at random plotted.
196
197         the plot has the users on the x-axis sorted by their value on
           property p and
198         with the items on the y-axis sorted by their value on property p and
199         the ratings plotted at the corresponding x-y position.
200         """
201         plt.ion()

```

```

202     fig, ax = plt.subplots()
203     ax.set_xlabel("users")
204     ax.set_ylabel("items")
205     user_vals = [self.user_prop[u][p]
206                 for u in self.users]
207     item_vals = [self.item_prop[i][p]
208                for i in self.items]
209     ax.axis([min(user_vals)-0.02,
210             max(user_vals)+0.05,
211             min(item_vals)-0.02,
212             max(item_vals)+0.05])
213     if plot_all:
214         for (u,i,r) in self.training_data:
215             ax.text(self.user_prop[u][p],
216                    self.item_prop[i][p],
217                    str(r))
218     else:
219         for i in range(num_points):
220             (u,i,r) = random.choice(self.training_data)
221             ax.text(self.user_prop[u][p],
222                    self.item_prop[i][p],
223                    str(r))
224     plt.show()

```

17.1.2 Loading Rating Sets from Files and Websites

This assumes the form of the Movielens datasets Harper and Konstan [2015], available from <http://grouplens.org/datasets/movielens/>.

The Movielens datasets consist of *(user, movie, rating, timestamp)* tuples. The aim here is to predict the future from the past. Tuples with a timestamp before `data_split` form the training set, and those with a timestamp after form the test set.

A rating set can be read from the Internet or read from a local file. The default is to read the Movielens 100K dataset from the Internet. It would be more efficient to save the dataset as a local file, and then set `local_file = True`, as then it will not need to download the dataset every time the program is run.

```

_____relnCollFilt.py — (continued)_____
226 class Rating_set_from_file(Rating_set):
227     def __init__(self,
228                 date_split=892000000,
229                 local_file=False,
230                 url="http://files.grouplens.org/datasets/movielens/ml-100k/u.data",
231                 file_name="u.data"):
232         self.display(1,"Collaborative Filtering Dataset. Reading...")
233         if local_file:
234             lines = open(file_name,'r')
235         else:

```

```

236         lines = (line.decode('utf-8') for line in
237                 urllib.request.urlopen(url))
238     all_ratings = (tuple(int(e) for e in line.strip().split('\t'))
239                  for line in lines)
240     self.training_data = []
241     self.training_stats = {1:0, 2:0, 3:0, 4:0, 5:0}
242     self.test_data = []
243     self.test_stats = {1:0, 2:0, 3:0, 4:0, 5:0}
244     for (user,item,rating,timestamp) in all_ratings:
245         if timestamp < date_split: # rate[3] is timestamp
246             self.training_data.append((user,item,rating))
247             self.training_stats[rating] += 1
248         else:
249             self.test_data.append((user,item,rating))
250             self.test_stats[rating] += 1
251     self.display(1, "...read:", len(self.training_data), "training
252     ratings and",
253     len(self.test_data), "test ratings")
254     tr_users = {user for (user,item,rating) in self.training_data}
255     test_users = {user for (user,item,rating) in self.test_data}
256     self.display(1, "users:", len(tr_users), "training,", len(test_users), "test,",
257                 len(tr_users & test_users), "in common")
258     tr_items = {item for (user,item,rating) in self.training_data}
259     test_items = {item for (user,item,rating) in self.test_data}
260     self.display(1, "items:", len(tr_items), "training,", len(test_items), "test,",
261                 len(tr_items & test_items), "in common")
262     self.display(1, "Rating statistics for training set:
263     ",self.training_stats)
264     self.display(1, "Rating statistics for test set: ",self.test_stats)

```

17.1.3 Ratings of top items and users

Sometimes it is useful to plot a property for all $(user, item, rating)$ triples. There are too many such triples in the data set. The method `create_top_subset` creates a much smaller dataset where this makes sense. It picks the most rated items, then picks the users who have the most ratings on these items. It is designed for depicting the meaning of properties, and may not be useful for other purposes. A resulting plot is shown in Figure 17.3. Different runs will give different answers as the set of users and movies is slece randomly.

relnCollFilt.py — (continued)

```

263 class Rating_set_top_subset(Rating_set):
264
265     def __init__(self, rating_set, num_items = (20,40), num_users =
266                 (20,24)):
267         """Returns a subset of the ratings by picking the most rated items,
268         and then the users that have most ratings on these, and then all of
269         the
270         ratings that involve these users and items.

```

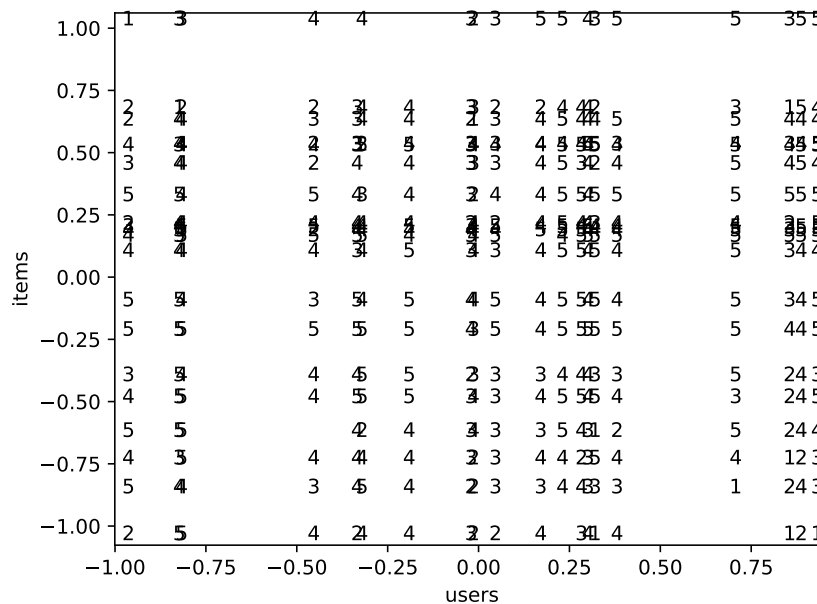

Figure 17.3: learner1.plot_property(0) for 20 most rated items and 20 users with most ratings on these. Users and items with similar property values overwrite each other.

```

269     num_items is (ni,si) which selects ni users at random from the top
        si users
270     num_users is (nu,su) which selects nu items at random from the top
        su items
271     """
272     (ni, si) = num_items
273     (nu, su) = num_users
274     items = {item for (user,item,rating) in rating_set.training_data}
275     item_counts = {i:0 for i in items}
276     for (user,item,rating) in rating_set.training_data:
277         item_counts[item] += 1
278
279     items_sorted = sorted((item_counts[i],i) for i in items)
280     top_items = random.sample([item for (count, item) in
        items_sorted[-si:]], ni)
281     set_top_items = set(top_items)
282
283     users = {user for (user,item,rating) in rating_set.training_data}
284     user_counts = {u:0 for u in users}
285     for (user,item,rating) in rating_set.training_data:
286         if item in set_top_items:
287             user_counts[user] += 1

```

```

288
289     users_sorted = sorted((user_counts[u],u) for u in users)
290     top_users = random.sample([user for (count, user) in
291         users_sorted[-su:]], nu)
292     set_top_users = set(top_users)
293
294     self.training_data = [ (user,item,rating)
295         for (user,item,rating) in rating_set.training_data
296         if user in set_top_users and item in set_top_items]
297     self.test_data = []
298
299 def show_top_ratings():
300     movielens = Rating_set_from_file()
301     movielens_subset = Rating_set_top_subset(movielens,num_items = (20,40),
302         num_users = (20,40))
303     learner_s = CF_learner(movielens_subset, num_properties=1)
304     learner_s.learn(100)
305     learner_s.plot_property(0,plot_all=True)

```

Testing.

```

_____relnCollFilt.py — (continued)_____
305 def test(num_properties = 1):
306     global learner1 # allows for more queries of model
307     movielens = Rating_set_from_file()
308     learner1 = CF_learner(movielens, num_properties = num_properties)
309     learner1.learn(50)
310     learner1.plot_predictions(examples = "training")
311     learner1.plot_predictions(examples = "test")
312     # learner1.plot_property(0)
313     # movielens_subset = Rating_set_top_subset(movielens,num_items =
314         (20,40), num_users = (20,40))
315     # learner_s = CF_learner(movielens_subset, num_properties=1)
316     # learner_s.learn(1000)
317     # learner_s.plot_property(0,plot_all=True)
318
319 if __name__ == "__main__":
320     test()

```

17.2 Relational Probabilistic Models

The following implements relational belief networks – belief networks with plates. Plates correspond to logical variables.

```

_____relnProbModels.py — Relational Probabilistic Models: belief networks with plates_____
11 from display import Displayable
12 from probGraphicalModels import BeliefNetwork
13 from variable import Variable
14 from probRC import ProbRC

```

```

15 | from probFactors import Prob
16 | import random
17 |
18 | boolean = [False, True]

```

A ParVar is a parametrized random variable, which consists of the name, a list of logical variables (plates), a domain, and a position. For each assignment of an entity to each logical variable, there is a random variable in a grounding.

```

_____relnProbModels.py — (continued)_____
20 | class ParVar(object):
21 |     """Parametrized random variable"""
22 |     def __init__(self, name, log_vars, domain, position=None):
23 |         self.name = name # string
24 |         self.log_vars = log_vars
25 |         self.domain = domain # list of values
26 |         self.position = position if position else (random.random(),
27 |                                                    random.random())
28 |         self.size = len(domain)

```

The class RBN is of relational belief networks. A relational belief network consists of a title, a set of parvariables, and a set of parfactors.

```

_____relnProbModels.py — (continued)_____
29 | class RBN(Displayable):
30 |     def __init__(self, title, parvars, parfactors):
31 |         self.title = title
32 |         self.parvars = parvars
33 |         self.parfactors = parfactors
34 |         self.log_vars = {V for PV in parvars for V in PV.log_vars}

```

The grounding of a belief network with a population for each logical variable is a belief network, for which any of the belief network inference algorithms work.

```

_____relnProbModels.py — (continued)_____
36 | def ground(self, populations, offsets=None):
37 |     """Ground the belief network with the populations of the logical
38 |         variables.
39 |         populations is a dictionary that maps each logical variable to the
40 |         list of individuals.
41 |         Returns a belief network representation of the grounding.
42 |     """
43 |     assert all(lv in populations for lv in self.log_vars), f"{{lv for
44 |         lv in self.log_vars if lv not in populations}} have no
45 |         population"
46 |     self.cps = [] # conditional probabilities in the grounding
47 |     self.var_dict = {} # ground variables created
48 |     for pp in self.parfactors:
49 |         self.ground_parfactor(pp, list(self.log_vars), populations, {},
50 |                               offsets)

```

```

46         return BeliefNetwork(self.title+"_grounded",
47                               self.var_dict.values(), self.cps)
48     def ground_parfactor(self, parfactor, lvs, populations, context,
49                          offsets):
50         """
51         parfactor is the parfactor to get instances of
52         lvs is a list of the logical variables in parfactor not assigned in
53         context
54         populations is {logical_variable: population} dictionary
55         context is a {logical_variable:value} dictionary for
56         logical_variable in parfactor
57         offsets a {loc_var:(x_offset,y_offset)} dictionary or None
58         """
59         if lvs == []:
60             if isinstance(parfactor, Prob):
61                 self.cps.append(Prob(self.ground_pvr(parfactor.child,context,offsets),
62                                     [self.ground_pvr(p,context,offsets)
63                                      for p in parfactor.parents],
64                                     parfactor.values))
65             else:
66                 print("Parfactor not implemented for",parfactor,"of
67                       type",type(parfactor))
68         else:
69             for val in populations[lvs[0]]:
70                 self.ground_parfactor(parfactor, lvs[1:], populations,
71                                     {lvs[0]:val}|context, offsets)
72
73     def ground_pvr(self, prv, context, offsets):
74         """grounds a parametrized random variable with respect to a context
75         prv is a parametrized random variable
76         context is a logical_variable:value dictionary that assigns all
77         logical variables in prv
78         offsets a {loc_var:(x_offset,y_offset)} dictionary or None
79         """
80         if isinstance(prv,ParVar):
81             args = tuple(context[lv] for lv in prv.log_vars)
82             if (prv,args) in self.var_dict:
83                 return self.var_dict[(prv,args)]
84             else:
85                 new_gv = GrVar(prv, args, offsets)
86                 self.var_dict[(prv,args)] = new_gv
87                 return new_gv
88         else: # allows for non-parametrized random variables
89             return prv

```

A GrVar is a variable constructed by grounding a parametrized random variable with respect to a tuple of values for the logical variables.

relnProbModels.py — (continued)

```
84 class GrVar(Variable):
```

```

85 """Grounded Variable"""
86 def __init__(self, parvar, args, offsets = None):
87     """A grounded variable
88     parvar is the parametrized variable
89     args is a tuple of a value for each random variable
90     offsets is a map between the value and the (x,y) offsets
91     """
92     if offsets:
93         pos = sum_positions([parvar.position]+[offsets[a] for a in
94                               args])
95     else:
96         pos = sum_positions([parvar.position,
97                               (random.uniform(-0.2,0.2),random.uniform(-0.2,0.2))])
98     Variable.__init__(self,parvar.name+"("+".join(args)+")",
99                       parvar.domain, pos)
100     self.parvar= parvar
101     self.args = tuple(args)
102     self.hash_value = None
103
104 def __hash__(self):
105     if self.hash_value is None: # only hash once
106         self.hash_value = hash((self.parvar, self.args))
107     return self.hash_value
108
109 def __eq__(self, other):
110     return isinstance(other,GrVar) and self.parvar == other.parvar and
111         self.args == other.args
112
113 def sum_positions(poslist):
114     (x,y) = (0,0)
115     for (xo,yo) in poslist:
116         x += xo
117         y += yo
118     return (x,y)

```

The following is a representation of Examples 17.5-17.7 of Poole and Mackworth [2023]. The plate model – represented here using grades – is shown in Figure 17.4. The observation in obs corresponds to the dataset of Figure 17.3. The grounding in grades_{gr} corresponds to Figure 17.5, but also includes the Grade variables not needed to answer the query (see exercise below).

Try the commented out queries to the Python shell:

```

relnProbModels.py — (continued)
116 Int = ParVar("Intelligent", ["St"], boolean, position=(0.0,0.7))
117 Grade = ParVar("Grade", ["St","Co"], ["A", "B", "C"], position=(0.2,0.6))
118 Diff = ParVar("Difficult", ["Co"], boolean, position=(0.3,0.9))
119
120 pg = Prob(Grade, [Int, Diff],
121           [{"A": 0.1, "B":0.4, "C":0.5},
122            {"A": 0.01, "B":0.09, "C":0.9}],
123           [{"A": 0.9, "B":0.09, "C":0.01},

```

```

124         {"A": 0.5, "B":0.4, "C":0.1}]]))
125 pi = Prob( Int, [], [0.5, 0.5])
126 pd = Prob( Diff, [], [0.5, 0.5])
127 grades = RBN("Grades RBN", {Int, Grade, Diff}, {pg,pi,pd})
128
129 students = ["s1", "s2", "s3", "s4"]
130 st_offsets = {st:(0,-0.2*i) for (i,st) in enumerate(students)}
131 courses = ["c1", "c2", "c3", "c4"]
132 co_offsets = {co:(0.2*i,0) for (i,co) in enumerate(courses)}
133 grades_gr = grades.ground({"St": students, "Co": courses},
134                          offsets= st_offsets | co_offsets)
135
136 obs = {GrVar(Grade,["s1","c1"]):"A", GrVar(Grade,["s2","c1"]):"C",
137        GrVar(Grade,["s1","c2"]):"B",
138        GrVar(Grade,["s2","c3"]):"B", GrVar(Grade,["s3","c2"]):"B",
139        GrVar(Grade,["s4","c3"]):"B"}
140
141 # grades_rc = ProbRC(grades_gr)
142 # grades_rc.show_post({GrVar(Grade,["s1","c1"]):"A"},fontsize=10)
143 #
144     grades_rc.show_post({GrVar(Grade,["s1","c1"]):"A",GrVar(Grade,["s2","c1"]):"C"})
145 #
146     grades_rc.show_post({GrVar(Grade,["s1","c1"]):"A",GrVar(Grade,["s2","c1"]):"C",
147                        GrVar(Grade,["s1","c2"]):"B"})
148 # grades_rc.show_post(obs,fontsize=10)
149 # grades_rc.query(GrVar(Grade,["s3","c4"]), obs)
150 # grades_rc.query(GrVar(Grade,["s4","c4"]), obs)
151 # grades_rc.query(GrVar(Int,["s3"]), obs)
152 # grades_rc.query(GrVar(Int,["s4"]), obs)

```

Figure 17.4 shows the distribution over ground variables after the 3rd `show_post` in the code above (with 3 grades observed).

Exercise 17.5 What are advantages and disadvantages of using this formulation over using `CF_learner` with `grades_rs`? Think about overfitting, and where the parameters come from.

Exercise 17.6 The grounding above creates a random variable for each element for each possible combination of individuals in the populations. Change it so that it only creates as many random variables as needed to answer a query. For example, for the observations and queries above, only the variables in Figure 17.5 in Poole and Mackworth [2023] need to be created.

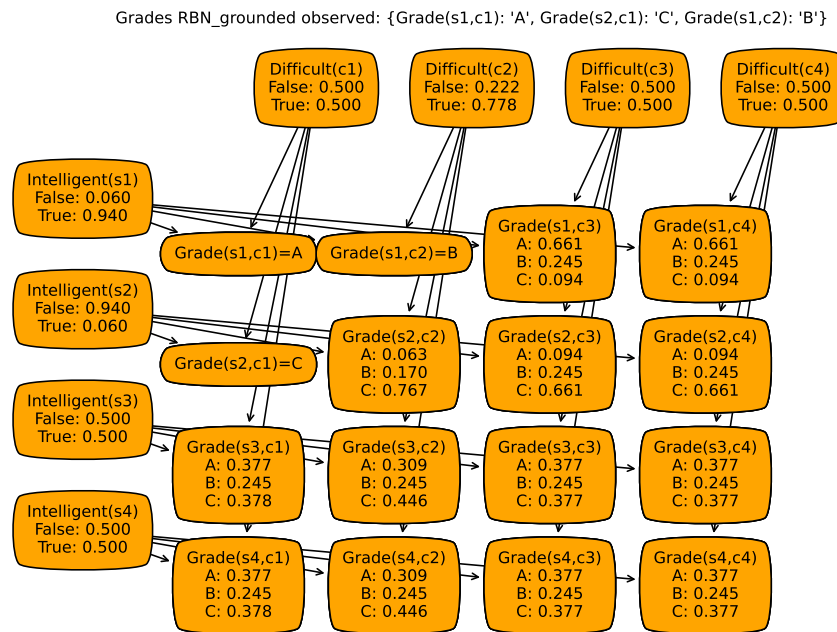

Figure 17.4: Grounded network with three observations

Version History

- 2026-03-08 Version 0.9.18. Many small changes. New: movie ratings for supervised learning (with lots of exercises), language model tokenizer.
- 2025-07-07 Version 0.9.17. Made it more compatible with Jupyter Notebooks by not running anything if the file is imported, and using object-oriented interface in Matplotlib. (Thanks to Jason Miller for feedback).
- 2025-04-23 Version 0.9.16. Learning and neural networks more modular. Still a candidate release for Version 1.0.
- 2024-12-19 Version 0.9.15. GUIs made more consistent and robust (with closing working).
- 2024-12-09 Version 0.9.14. Code simplified, user manual has more explanation. This is a candidate release for Version 1.0.
- 2024-04-30 Version 0.9.13: Minor changes including counterfactual reasoning.
- 2023-12-06 Version 0.9.12: Top-down proof for Datalog (ch 15) and triple store (ch 16)
- 2023-11-21 Version 0.9.11 updated and simplified relational learning, show relational belief networks
- 2023-11-07 Version 0.9.10 Improved GUIs and test cases for decision-theoretic planning (MDPs) and reinforcement learning.
- 2023-10-6 Version 0.9.8 GUIs for search, Bayesian learning, causality and many smaller changes.

- 2023-07-31 Version 0.9.7 includes relational probabilistic models and smaller changes
- 2023-06-06 Version 0.9.6 controllers are more consistent. Many smaller changes.
- 2022-08-13 Version 0.9.5 major revisions including extra code for causality and deep learning
- 2021-07-08 Version 0.9.1 updated the CSP code to have the same representation of variables as used by the probability code
- 2021-05-13 Version 0.9.0 Major revisions to chapters 8 and 9. Introduced recursive conditioning, simplified much code. New section on multi-agent reinforcement learning.
- 2020-11-04 Version 0.8.6 simplified value iteration for MDPs.
- 2020-10-20 Version 0.8.4 planning simplified and fixed arc costs.
- 2020-07-21 Version 0.8.2 added positions and string to constraints
- 2019-09-17 Version 0.8.0 represented blocks world (Section 6.1.2) due to bug found by Donato Meoli.

Bibliography

- Chen, T. and Guestrin, C. (2016), Xgboost: A scalable tree boosting system. In *KDD '16: 22nd ACM SIGKDD International Conference on Knowledge Discovery and Data Mining*, pages 785–794, URL <https://doi.org/10.1145/2939672.2939785>. 192
- Chollet, F. (2021), *Deep Learning with Python*. Manning. 195
- Chollet, F. and Watson, M. (2025), *Deep Learning with Python*. Manning, 3rd edition, URL <https://deeplearningwithpython.io>. 222
- Dua, D. and Graff, C. (2017), UCI machine learning repository. URL <https://archive.ics.uci.edu/ml>. 149
- Glorot, X. and Bengio, Y. (2010), Understanding the difficulty of training deep feedforward neural networks. In *Thirteenth International Conference on Artificial Intelligence and Statistics*, pages 249–256, URL <https://proceedings.mlr.press/v9/glorot10a.html>. 196
- Goodfellow, I., Bengio, Y., and Courville, A. (2016), *Deep Learning*. MIT Press, URL <https://www.deeplearningbook.org>. 203
- Harper, F. M. and Konstan, J. A. (2015), The MovieLens datasets: History and context. *ACM Transactions on Interactive Intelligent Systems*, 5(4). 183, 416
- Ke, G., Meng, Q., Finley, T., Wang, T., Chen, W., Ma, W., Ye, Q., and Liu, T.-Y. (2017), LightGBM: A highly efficient gradient boosting decision tree. In *Advances in Neural Information Processing Systems 30*. 192
- Koren, Y., Bell, R., and Volinsky, C. (2009), Matrix factorization techniques for recommender systems. *IEEE Computer*, 42(8):30–37. 409

- Lichman, M. (2013), UCI machine learning repository. URL <https://archive.ics.uci.edu/ml>. 149
- Pearl, J. (2009), *Causality: Models, Reasoning and Inference*. Cambridge University Press, 2nd edition. 239, 306
- Pérez, F. and Granger, B. E. (2007), IPython: a system for interactive scientific computing. *Computing in Science and Engineering*, 9(3):21–29, URL <https://ipython.org>. 10
- Poole, D. L. and Mackworth, A. K. (2023), *Artificial Intelligence: foundations of computational agents*. Cambridge University Press, 3rd edition, URL <https://artint.info>. 9, 25, 27, 39, 40, 48, 50, 51, 75, 114, 123, 173, 203, 234, 237, 238, 245, 246, 289, 324, 327, 329, 330, 347, 349, 355, 360, 362, 380, 388, 395, 396, 398, 400, 406, 409, 422, 423
- Radford, A., Wu, J., Child, R., Luan, D., Amodei, D., and Sutskever, I. (2019), Language models are unsupervised multitask learners. URL https://cdn.openai.com/better-language-models/language_models_are_unsupervised_multitask_learners.pdf. 210
- Sennrich, R., Haddow, B., and Birch, A. (2016), Neural machine translation of rare words with subword units. In Erk, K. and Smith, N. A. (Eds.), *Proceedings of the 54th Annual Meeting of the Association for Computational Linguistics (Volume 1: Long Papers)*, pages 1715–1725, Association for Computational Linguistics, Berlin, Germany, URL <https://aclanthology.org/P16-1162/>. 210

Index

- α - β pruning, 384
- A* search, 54
- A* Search, 61
- action, 125
- agent, 25, 343
- argmax, 19
- assignment, 70, 227
- assumable, 119
- asynchronous value iteration, 339
- augmented feature, 161
- Bayesian network, 234
- belief network, 234
- blocks world, 128
- Boolean feature, 150
- bottom-up proof, 112
- branch-and-bound search, 65
- class
 - Action_instance*, 142
 - Agent*, 26
 - Arc*, 42
 - Askable*, 109
 - Assumable*, 119
 - BNfromDBN*, 279
 - BeliefNetwork*, 235
 - Boosted_dataset*, 189
 - Boosting_learner*, 190
 - Branch_and_bound*, 107
 - CF_learner*, 409
 - CPD*, 229
 - CPDrename*, 277
 - CSP*, 71
 - CSP_from_STRIPs*, 138
 - Clause*, 109, 394
 - Con_solver*, 87
 - ConstantCPD*, 229
 - Constraint*, 70
 - DBN*, 277
 - DBNVEfilter*, 281
 - DBNvariable*, 275
 - DF_Branch_and_bound*, 65
 - DT_learner*, 168
 - Data_from_file*, 158
 - Data_from_files*, 159
 - Data_set*, 151
 - Data_set_augmented*, 161
 - DecisionFunction*, 317
 - DecisionNetwork*, 310
 - DecisionVariable*, 310
 - Displayable*, 18
 - Dist*, 233

- Dropout_layer*, 204
- EM_learner*, 292
- Env_from_MDP*, 348
- Environment*, 26
- Evaluate*, 156
- Factor*, 227
- FactorMax*, 322
- FactorObserved*, 251
- FactorRename*, 276
- FactorSum*, 251
- Forward_STRIPS*, 131
- FrontierPQ*, 60
- GTB_learner*, 192
- GibbsSampling*, 261
- GrVar*, 421
- GraphicalModel*, 234
- GridDomain*, 336
- HMM*, 265
- HMMVEfilter*, 267
- HMM_Controlled*, 269
- HMM_Local*, 269
- HMMparticleFilter*, 272
- IFeq*, 232
- InferenceMethod*, 242, 299
- KB*, 110, 396
- KBA*, 119
- KBT*, 406
- K_fold_dataset*, 173
- K_means_learner*, 287
- Layer*, 195
- Learner*, 163
- LikelihoodWeighting*, 257
- Linear_complete_layer*, 197
- Linear_complete_layer_RMS_Prop*, 203
- Linear_learner*, 176
- LogisticRegression*, 230
- MDP*, 324
- MDPtiny*, 328
- Magic_sum*, 381
- Model_based_reinforcement_learner*, 362
- Momentum*, 202
- Monster_game_env*, 331, 349
- NN*, 199
- Naive_learner*, 166
- Node*, 380
- NoisyOR*, 230
- POP_node*, 143
- POP_search_from_STRIPS*, 144
- ParVar*, 420
- ParticleFiltering*, 258
- Partyenv*, 347
- Path*, 45
- Planning_problem*, 126
- Plot_env*, 36
- Plot_prices*, 29
- Predict*, 165
- Prob*, 232
- ProbDT*, 232
- ProbRC*, 246
- ProbSearch*, 245
- Q_learner*, 352
- RBN*, 420
- RC_DN*, 318
- RL_agent*, 344
- RL_env*, 343
- Rating_set*, 416
- ReLU_layer*, 198
- Regression_STRIPS*, 135
- RejectionSampling*, 256
- Rob_body*, 31
- Rob_env*, 35
- Rob_middle_layer*, 33
- Rob_top_layer*, 35
- Runtime_distribution*, 103
- SARSA*, 354
- SARSA_LFA_learner*, 368
- SGD*, 201
- SLSearcher*, 96
- STRIPS_domain*, 126
- SameAs*, 233
- SamplingInferenceMethod*, 256
- Search_from_CSP*, 83, 85
- Search_problem*, 41
- Search_problem_from_explicit_graph*, 43
- Search_with_AC_from_CSP*, 94
- Searcher*, 54
- SearcherGUI*, 56

- SearcherMPP*, 63
- Show_Localization*, 270
- Sigmoid_layer*, 199
- SoftConstraint*, 105
- State*, 131
- Strips*, 125
- Subgoal*, 135
- TP_agent*, 28
- TP_env*, 27
- TabFactor*, 231
- TripleStore*, 403
- Updatable_priority_queue*, 101
- Utility*, 309
- UtilityTable*, 309
- VE*, 250
- VE_DN*, 322
- Variable*, 69
- clause, 109
- collaborative filtering, 409
- comprehensions, 12
- condition, 70
- conditional probability distribution (CPD), 229
- consistency algorithms, 87
- constraint, 70
- constraint satisfaction problem, 69
- CPD (conditional probability distribution), 229
- cross validation, 173
- CSP, 69
 - consistency, 87
 - domain splitting, 89, 94
 - search, 85
 - stochastic local search, 96
- currying, 74
- datalog, 393
- dataset, 150
- DBN
 - filtering, 281
 - unrolling, 279
- DBN (dynamic belief network), 275
- debugging, 115
- decision network, 309
- decision tree learning, 168
- decision tree factors, 232
- decision variable, 309
- deep learning, 195
- display, 19
- Displayable, 18
- domain splitting, 89, 94
- Dropout, 204
- dynamic belief network (DBN), 275
 - representation, 275
- EM, 292
- environment, 25, 26, 343
- error, 155
- example, 150
- explanation, 115
- explicit graph, 43
- factor, 227, 231
- factor_times, 252
- feature, 150, 152
- feature engineering, 149
- file
 - agentBuying.py*, 27
 - agentEnv.py*, 31
 - agentFollowTarget.py*, 39
 - agentMiddle.py*, 33
 - agentTop.py*, 35
 - agents.py*, 26
 - cspConsistency.py*, 87
 - cspConsistencyGUI.py*, 91
 - cspDFS.py*, 83
 - cspExamples.py*, 74
 - cspProblem.py*, 70
 - cspSLS.py*, 96
 - cspSearch.py*, 85
 - cspSoft.py*, 105
 - decnNetworks.py*, 309
 - display.py*, 18
 - knowledgeGraph.py*, 403
 - knowledgeReasoning.py*, 406
 - learnBayesian.py*, 283
 - learnBoosting.py*, 189
 - learnCrossValidation.py*, 173
 - learnDT.py*, 168
 - learnEM.py*, 292

learnKMeans.py, 287
learnLinear.py, 176
learnNN.py, 195
learnNgram.py, 217
learnNgramKeras.py, 222
learnNoInputs.py, 165
learnProblem.py, 150
learnRatings.py, 184
learnTokenizer.py, 211
logicAssumables.py, 119
logicBottomUp.py, 112
logicExplain.py, 115
logicNegation.py, 122
logicProblem.py, 109
logicRelation.py, 393
logicTopDown.py, 114
masLearn.py, 385
masMiniMax.py, 383
masProblem.py, 380
mdpExamples.py, 324
mdpGUI.py, 336
mdpProblem.py, 324
probCounterfactual.py, 302
probDBN.py, 275
probDo.py, 299
probExamples.py, 237
probFactors.py, 227
probGraphicalModels.py, 234
probHMM.py, 265
probLocalization.py, 269
probRC.py, 245
probStochSim.py, 254
probVE.py, 250
pythonDemo.py, 13
relnCollFilt.py, 409
relnExamples.py, 396
relnProbModels.py, 419
rlExamples.py, 347
rlFeatures.py, 368
rlGUI.py, 372
rlGameFeature.py, 365
rlModelLearner.py, 362
rlProblem.py, 343
rlQExperienceReplay.py, 357
rlQLearner.py, 352
rlStochasticPolicy.py, 360
searchBranchAndBound.py, 65
searchExample.py, 47
searchGUI.py, 56
searchGeneric.py, 54
searchGrid.py, 64
searchMPP.py, 63
searchProblem.py, 41
searchTest.py, 67
stripsCSPPPlanner.py, 138
stripsForwardPlanner.py, 131
stripsHeuristic.py, 133
stripsPOP.py, 142
stripsProblem.py, 125
stripsRegressionPlanner.py, 135
utilities.py, 19
variable.py, 69
 filtering, 267, 272
 DBN, 281
 flip, 20
 forward planning, 130
 frange, 152
 ftype, 152
 fully observable, 343

 game, 379
 Gibbs sampling, 261
 graphical model, 234

 heuristic planning, 133, 137
 hidden Markov model, 265
 hierarchical controller, 31
 HMM
 exact filtering, 267
 particle filtering, 272
 HMM (hidden Markov models), 265

 importance sampling, 258
 interact
 proofs, 116
 ipython, 10

 k-means, 287
 kernel, 161
 knowledge base, 110
 knowledge graph, 403

- learner, 163
- learning, 149–209, 283–297, 343–377, 409–419
 - cross validation, 173
 - decision tree, 168
 - deep, 195–209
 - deep learning, 195
 - EM, 292
 - k-means, 287
 - linear regression, 176
 - linear classification, 176
 - neural network, 195
 - no inputs, 164
 - reinforcement, 343–377
 - relational, 409
 - supervised, 149–194
 - with uncertainty, 283–297
- LightGBM, 192
- likelihood weighting, 257
- linear regression, 176
- linear classification, 176
- localization, 269
- logic program, 393
- logistic regression, 230
- logit, 178
- loss, 155

- magic square, 381
- magic-sum game, 381
- Markov Chain Monte Carlo, 261
- Markov decision process, 324
- max_display_level, 19
- MCMC, 261
- MDP, 324, 348
 - GUI, 336
- method
 - consistent*, 72
 - holds*, 71
 - maxh*, 133
 - zero*, 131
- minimax, 379
- minimax algorithm, 383
- minsets, 120
- model-based reinforcement learner, 362

- multiagent system, 379
- multiple path pruning, 63

- n-queens problem, 82
- naive search probabilistic inference, 245
- naughts and crosses, 381
- neural network, 195
- noisy-or, 230
- NotImplementedError, 26

- partial-order planner, 142
- particle filtering, 258
 - HMMs, 272
- planning, 125–148, 309–342
 - CSP, 138
 - decision network, 309
 - forward, 130
 - MDP, 324
 - partial order, 142
 - regression, 135
 - with certainty, 125–148
 - with learning, 362
 - with uncertainty, 309–342
- plotting
 - agents in time, 29
 - reinforcement learning, 346
 - robot environment, 36
 - run-time distribution, 103
 - stochastic simulation, 263
- predictor, 155
- Prob, 232
- probabilistic inference methods, 242
- probability, 227
- proof
 - bottom-up, 112
 - explanation, 115
 - top-down, 114, 398
- proposition, 109
- Python, 9

- Q learning, 352
- query, 242
- queryD0, 299

- RC, 246, 318

- recursive conditioning (RC), 246
- recursive conditioning for decision networks, 318
- regression planning, 135
- reinforcement learning, 343–377
 - environment, 343
 - feature-based, 365
 - model-based, 362
 - Q-learning, 352
- rejection sampling, 256
- relational learning, 409
- relations, 393
- ReLU, 198
- resampling, 259
- robot
 - body, 31
 - middle layer, 33
 - plotting, 36
 - top layer, 35
 - world, 35
- robot delivery domain, 126
- run time, 16
- runtime distribution, 103
- sampling, 254
 - importance sampling, 258
 - belief networks, 256
 - likelihood weighting, 257
 - particle filtering, 258
 - rejection, 256
- SARSA, 354
- scope, 70
- search, 41
 - A*, 54
 - branch-and-bound, 65
 - multiple path pruning, 63
- search_with_any_conflict, 98
- search_with_var_pq, 99
- show, 72, 236
- sigmoid, 178
- softmax, 178
- stochastic local search, 96
 - any-conflict, 98
 - two-stage choice, 99
- stochastic simulation, 254
- tabular factor, 231
- test
 - SLS, 104
- tic-tac-toe, 381
- top-down proof, 114, 398
- triple store, 403, 406
- uncertainty, 227
- unification, 395, 396
- unit test, 21, 61, 83, 113, 114, 116
- unrolling
 - DBN, 279
- updatable priority queue, 101
- utility, 309
- utility table, 309
- value iteration, 334
- variable, 69
- variable elimination (VE), 250
- variable elimination for decision networks, 321
- VE, 250
- XGBoost, 192
- yield, 13